



AMEREX VEHICLE SYSTEMS

PARTS BOOK & COMPONENT OVERVIEW



Index



Cylinder Components

Dry Agent Cylinder Overview	1
Dry Agent Cylinder Part Numbers	2
Dry Agent Cylinder: Vertical Mount	3
Dry Agent Cylinder: Horizontal Mount	4
Dry Chemical Discharge Valve	5
V250 Discharge Valve	6
Bracket Description & Part Numbers	7
V13 Bracket	8
V25 Bracket	9
VH25 Bracket	10
V30 Bracket	11
VH30 Bracket	12
V50 Bracket	13
VS50 Bracket	14
VS75 Bracket	15
Weld Rings	16
Combined Cylinder & Bracket Weight	17
Discharge Fitting Kit	18
Distributor Block: 3/4" x 1/2"	19
Distributor Block: 3/4" x 3/4"	20
Distributor Block: 1-1/4" x 3/4"	21
Distributor Block: 1-1/4" x 3/4"	22
Distributor Block: 3/4" x 1/2"	23
Nozzle Bracket	24
Discharge Nozzle	25

Actuation Components

Electric Control Head	26
Electric / Pneumatic Control Head	27



Actuation Components Continued

Pneumatic Control Head	28
Electric / Pneumatic Control Head: V250	29
Pneumatic Control Head: V250	30
Vent Plug	31
Linear Actuator	32
Linear Actuator Splitter	33
Electric Nitrogen Actuator	34
Manual Nitrogen Actuator	35
Electric / Manual Nitrogen Actuator	36
Actuator Bracket	37
Nitrogen Actuation Cylinder	38
Actuation Check Valve	39
Pressure Switch: 50 PSI	40

Control Panels

Circuit Monitor	41
Circuit Monitor Dimensional Data	42
Control Panel	43
Control Panel Dimensional Data	44
SafetyNet Operator Display Panel	45
SafetyNet Driver Panel	46
SafetyNet Detection Module	47
SafetyNet Detection / Release Module	48

Detection Components

Manual Actuation Switch	49
Spot Heat Detector	50
Linear Heat Detector	51
Safe IR Optical Flame Sensor	52
Methane Gas Sensor	53



Detection Components Continued

Select Methane Gas Sensor	54
Hydrogen Gas Sensor	55

Cables

Connection Cable Kit	56
Power Cable	57
Hazard Wire Lead Assembly	58
Linear Actuator Lead Assembly	59
Pressure Switch Cable	60
Pressure Switch Lead: Single Conductor	61
Agent Cylinder Pressure Switch	62
SafetyNet Interface Module	63
Alarm Test Module	64
Communication Cable	65

AMGaDS

AMGaDS IV Control Panel	66
AMGaDS IV Control Panel Data	67
Methane Gas Sensor	68
Select Methane Gas Sensor	69
Hydrogen Gas Sensor	70
Wiring Harness: Two Gas Sensors	71
Wiring Harness: Four Gas Sensors	72
Communication Cable	73

SMVS

SMVS Display Panel	74
SMVS Display Panel Data	75
SMVS Control Panel	76
SMVS Heat Sensor	77
Alarm Test Module	78



SMVS Continued

Communication Cable Driver / Display 79
 Power Lead Connector 80
 SMVS Agent Cylinder 81
 SMVS Cylinder Bracket 82
 SMVS Nozzle 83
 SMVS Spare Parts 84

Recharge and Service Tools

Tee Handle 85
 Recharge Adapter 86
 Hydrotest Adapters 87
 Distribution Hose Blowout Adapter 88
 V250 Cylinder Blowout Adapter 89
 Open End Pump Wrench 90
 Pneumatic Actuation Test Adapter 91
 Recharge Adapter 92

Additional Components

Replacement End of Line Module 93
 Replacement Battery 94
 Driver Panel Replacement Battery 95

Training Website



<https://training.amerex-fire.com/>

McWane Pocket Engineer

IOS

Android



<https://pe.mcwane.com/>

If accessed online, this booklet utilizes hyperlinks. Every part in the Index is linked and the Amerex logo located at the bottom left returns to Page I of the Index.





AGENT CYLINDER OVERVIEW

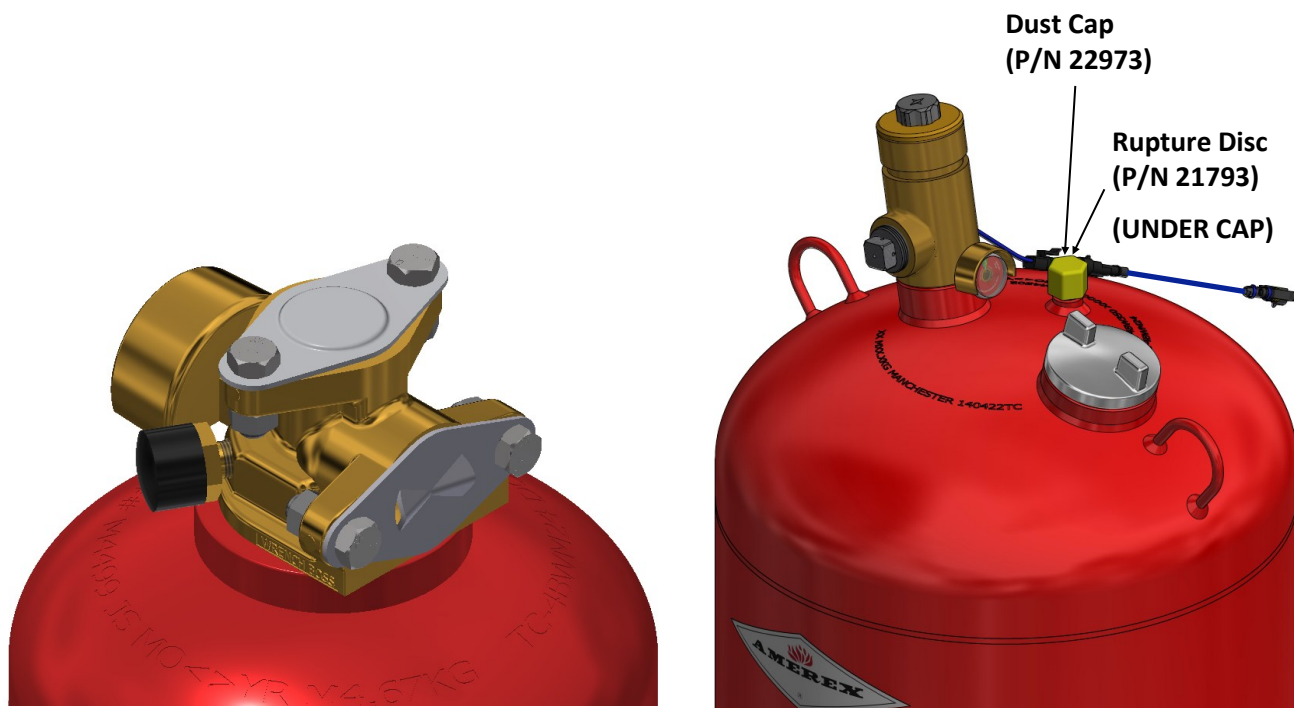

The Amerex Modular Dry Chemical System Agent Cylinders are available in multiple sizes, with different mounting options and orientations. The Agent Cylinders are shipped fully charged from the factory. Each Agent Cylinder includes a brass Agent Cylinder Valve with a Pressure Gauge and a safety Rupture Disc with Dust Cap installed. Agent Cylinders are pressurized with nitrogen gas to a pressure of 350 psi (2413 kPa) at 70°F (21°C). The Agent Cylinders are Zinc Primed and Red Powder Coated to prevent damage and extend life in highly corrosive environments. Agent Cylinders are DOT 4BW350, tested to 700 psi (4826 kPa) and require a hydrostatic test every twelve years, or more frequent intervals if warranted. The operating temperature range of the Agent Cylinders is -65°F to 150°F (-54°C to 66°C).





AGENT CYLINDER PART NUMBERS

Model	Part Number	Number of Nozzles
V13ABC	11345	2
V25ABC	10103	2, 3, or 4
VH25ABC	12252	2, 3, or 4
VH30ABC	22744	3, 4, or 5
V50ABC	10104	4, 6, or 8
VS50 ABC	16969	4, 6, or 8
V13ABC PRS SW	15647	2
V25ABC PRS SW	15591	2, 3, or 4
VH25ABC PRS SW	15524	2, 3, or 4
V30ABC PRS SW	23251	3, 4, or 5
VH30ABC PRS SW	22743	3, 4 or 5
V50ABC PRS SW	15590	4, 6, or 8
VS50 ABC PRS SW	16979	4, 6, or 8
VSR50 ABC PRS SW	23057	4, 6, or 8
VS75 ABC PRS SW	22373	10 or 12
VSR75 ABC PRS SW	23055	10 or 12
V250 ABC PRS SW	22838	12, 18, or 24
V13PK	11346	2
V25PK	10981	2, 3, or 4
VH25PK	12318	2, 3, or 4
V50PK	10982	4, 6, or 8
VS50 PK PRS SW	16980	4, 6, or 8

ABC = ABC Agent, PK = Purple K Agent, PRS SW = Pressure Switch on Valve





AGENT CYLINDER: VERTICAL MOUNT

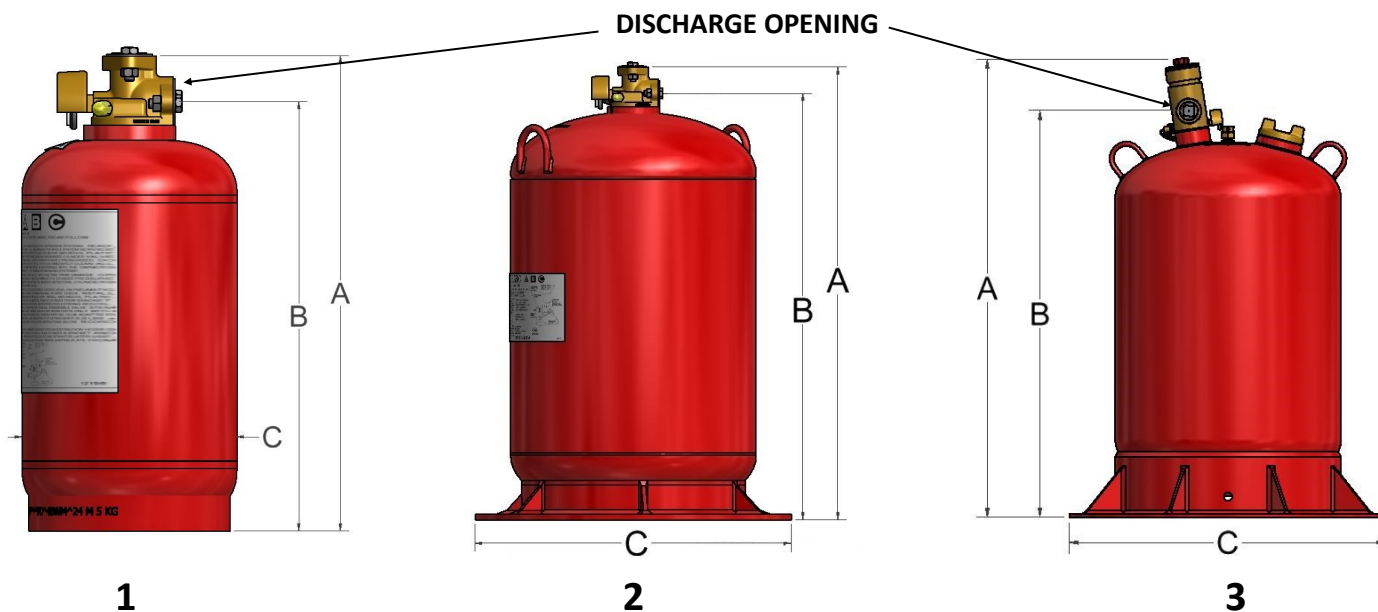

Agent Cylinder	Item	Overall Height (A) in (mm)	Height to Discharge Opening (B) in (mm)	Diameter (C) in (mm)	Agent Capacity lb. (kg)
V13	1	15.5 (394)	14.0 (356)	7.0 (178)	13 (5.9)
V25	1	17.6 (447)	16.0 (406)	9.0 (229)	25 (11.3)
V30	1	21.3 (541)	19.8 (502)	9.0 (229)	32 (14.5)
V50	1	31.3 (795)	30.0 (762)	9.0 (229)	50 (22.7)
VS50	1	16.3 (414)	14.8 (376)	14.0 (356)	50 (22.7)
VSR50	2	16.3 (414)	14.8 (376)	18.0 (457)	50 (22.7)
VS75	1	25.8 (655)	24.2 (615)	14.0 (356)	75 (34)
VSR75	2	25.8 (655)	24.2 (615)	18.0 (457)	75 (34)
V250	3	40.4 (1026)	36.0 (914)	28.0 (711)	250 (113.4)





AGENT CYLINDER: HORIZONTAL MOUNT

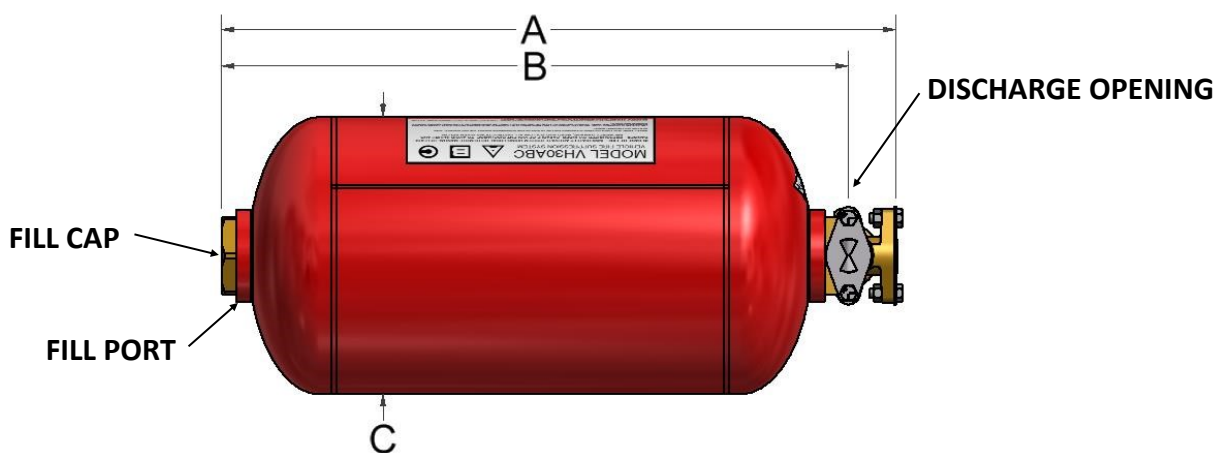

Agent Cylinder	Overall Length (A) in (mm)	Distance to Discharge Opening (B) in (mm)	Diameter (C) in (mm)	Agent Capacity lb.. (kg)
VH25	18.1 (460)	16.0 (406)	9.0 (229)	25 (11.3)
VH30	21.8 (554)	20.3 (516)	9.0 (229)	32 (14.5)





DRY CHEMICAL DISCHARGE VALVE

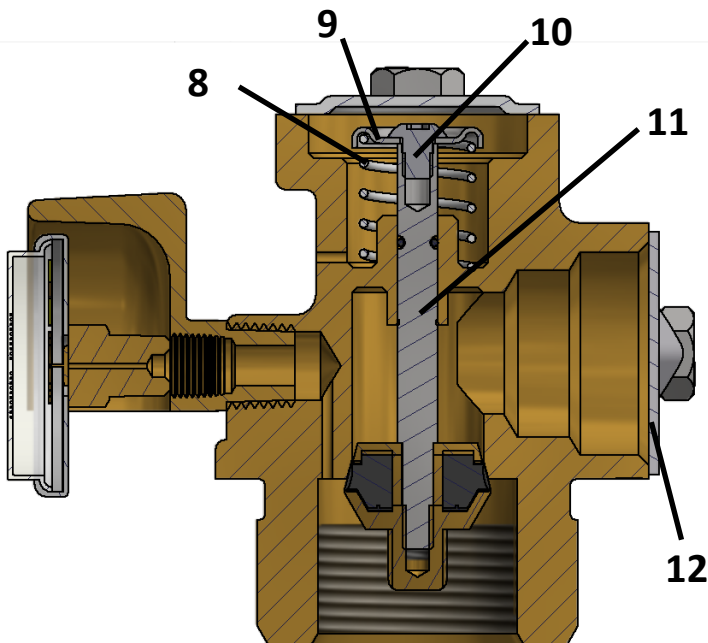
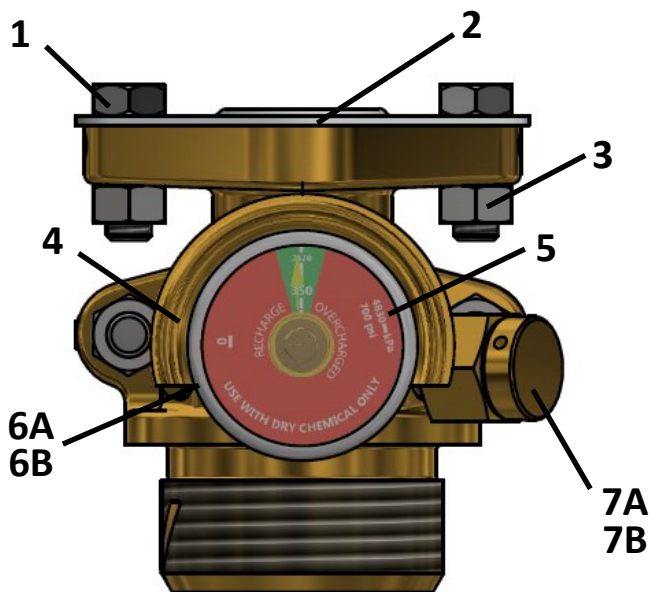

ITEM	DESCRIPTION	PART NO.
1	Bolts	10124-P006
2	Shipping Plates	10099-P006
3	Nuts	10125-P006
4	Gauge Guard	08680-P001
5	Gauge - 350 PSI	08714-P001
6A	Plug Socket	17781-P010
6B	Pressure Switch	17609-P001
7A	Disc Safety	26816-P001
7B	Dust Cap	25685
8	Spring	10097-P006
9	Washer Spring Retainer	10102-P012
10	Screw Valve Stem	10732-P012
11	VS Valve Stem Assembly	10095-P003
		10095-P010
12	Anti-Recoil Plates	10646-P006

The Cylinder Valve Assembly is made with a forged brass. The valve stem is made of stainless steel. The valve has a 350 psi pressure gauge protected by a gauge guard. The valve controls agent discharge via a spring loaded, internal sealing valve stem that must be depressed from the top of the valve either by pneumatic actuation or electrically by utilizing a Linear Actuator and Electric Control Head. These components are present in all cylinder valves except the V250.





V250 DISCHARGE VALVE

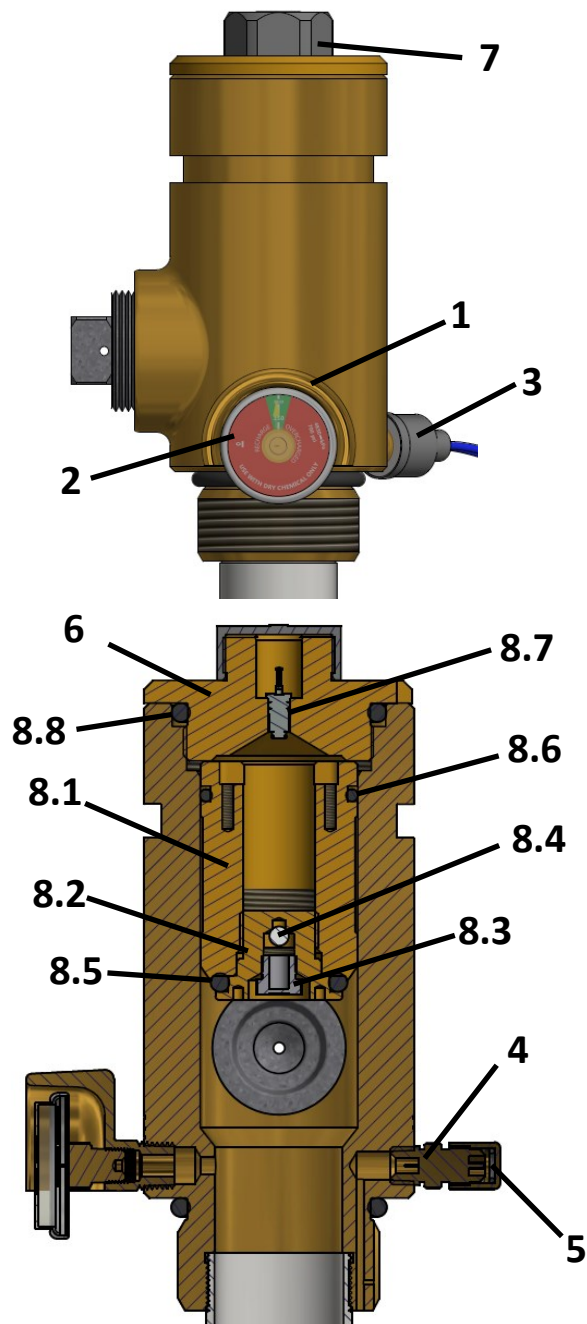

Item	Description	Part No.
1	Gauge Guard	08680-P001
2	Gauge - 350 PSI	08714-P001
3	Pressure Switch	17609-P001
4	Gas Valve with Core	07309-001
5	Gas Valve Cap with Seal	07310-001
6	Cap DCH Valve	17336
7	Valve Cap	17990
8	V250 Recharge Kit Asy	23009

Recharge Kit Consists of Items Below

8.1	Piston
8.2	Retaining O-ring
8.3	Breather Vent
8.4	Vent Ball
8.5	O-ring #320
8.6	O-ring #222
8.7	Shrader Core
8.8	O-ring #329

The Cylinder Valve Assembly is made with a forged brass body. The valve stem is made of stainless steel. The valve has a 350 psi pressure gauge protected by a gauge guard. The valve controls agent discharge via a spring loaded, internal sealing valve stem that must be depressed from the top of the valve either by pneumatic actuation or electrically by utilizing a Linear Actuator and Electric Control Head.





BRACKET DESCRIPTION & PART NUMBERS

Agent Cylinder	Cylinder Bracket	Part Number
V13	V13 Cylinder Bracket	12156
V25	V25 Cylinder Bracket	10180
VH25	VH25 Cylinder Bracket	11338
V30	V30 Cylinder Bracket	23259
VH30	VH30 Cylinder Bracket	22685
V50	V50 Cylinder Bracket	10181
VS50	VS50 Cylinder Bracket	16974
VS75	VS75 Cylinder Bracket	22260
VSR50/VSR75	VSR50/VSR75 Weld Ring	23406
V250	V250 Weld Ring	22966

VS Cylinder Brackets are Zinc Primed and Red Powder Coated to prevent damage and extend life in highly corrosive environments. Cylinder Brackets vary depending on the size and mounting orientation for the corresponding Agent Cylinder. Available Cylinder Brackets for each Agent Cylinder are shown above. Overall dimensions are shown in the following sections. Only the specified Amerex Cylinder Bracket can be used to mount an Agent Cylinder. Use of non Amerex Cylinder Brackets is prohibited.





V13 BRACKET



P/N: 12156

VS Cylinder Brackets are Zinc Primed and Red Powder Coated to prevent damage and extend life in highly corrosive environments. Cylinder Brackets vary depending on the size and mounting orientation for the corresponding Agent Cylinder. Dimensions are in inches [mm]. Only the specified Amerex Cylinder Bracket can be used to mount an Agent Cylinder. Use of non Amerex Cylinder Brackets is prohibited. The total weight of a V13 Cylinder and Bracket is 45 lb. (20.4 kg). Replacement bracket straps (P/N 14781) are available. A replacement bag (P/N 12305-P001) can be purchased to replace nuts, bolts, and washers.

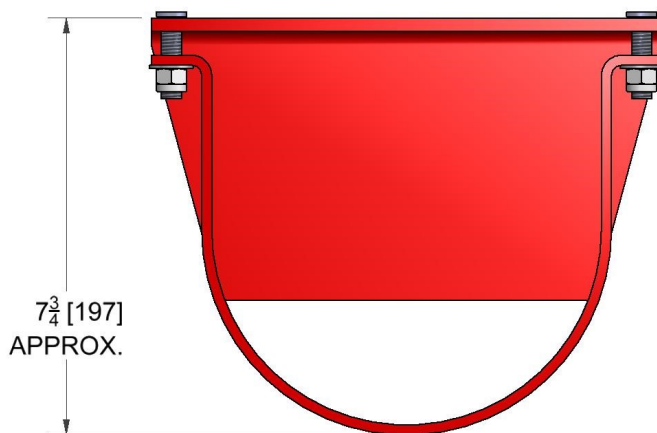
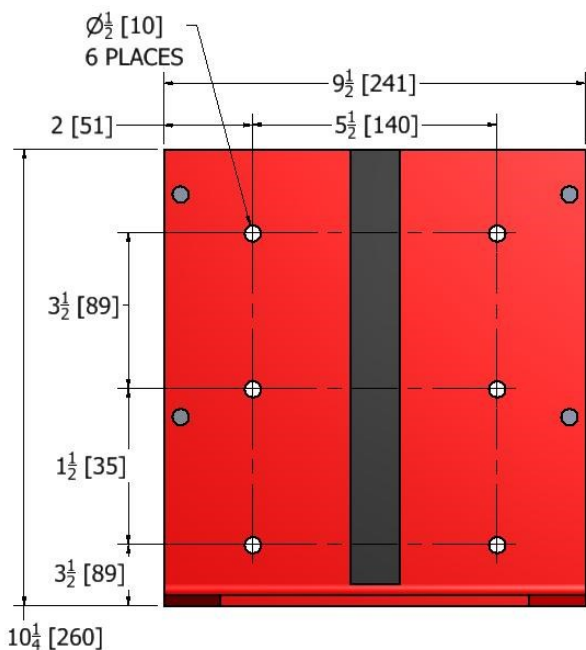



V25 BRACKET

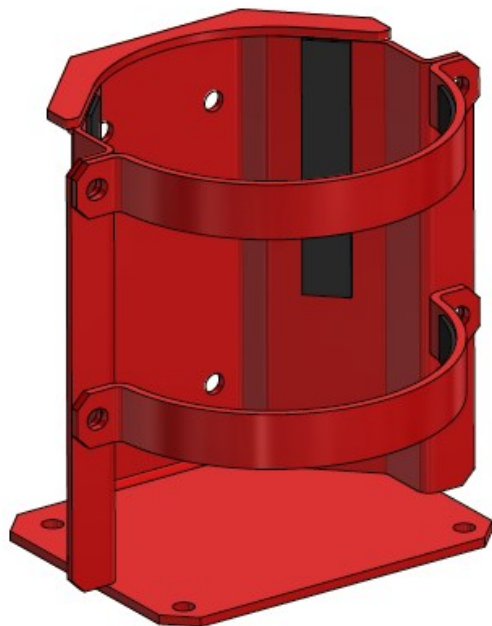

P/N: 10180

VS Cylinder Brackets are Zinc Primed and Red Powder Coated to prevent damage and extend life in highly corrosive environments. Cylinder Brackets vary depending on the size and mounting orientation for the corresponding Agent Cylinder. Dimensions are in inches [mm]. Only the specified Amerex Cylinder Bracket can be used to mount an Agent Cylinder. Use of non Amerex Cylinder Brackets is prohibited. The total weight of a V25 Cylinder and Bracket is 74 lb. (33.6 kg). Replacement bracket straps (P/N 14782) are available. A replacement bag (P/N 10244-P001) can be purchased to replace nuts, bolts, and washers.

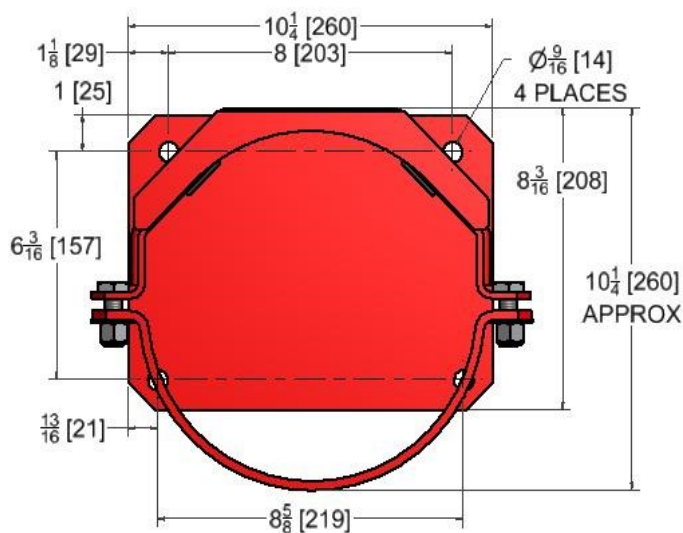
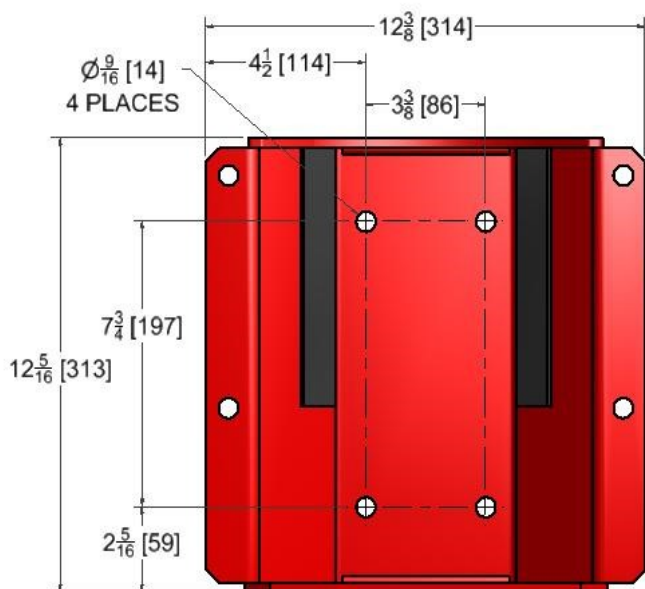



VH25 BRACKET

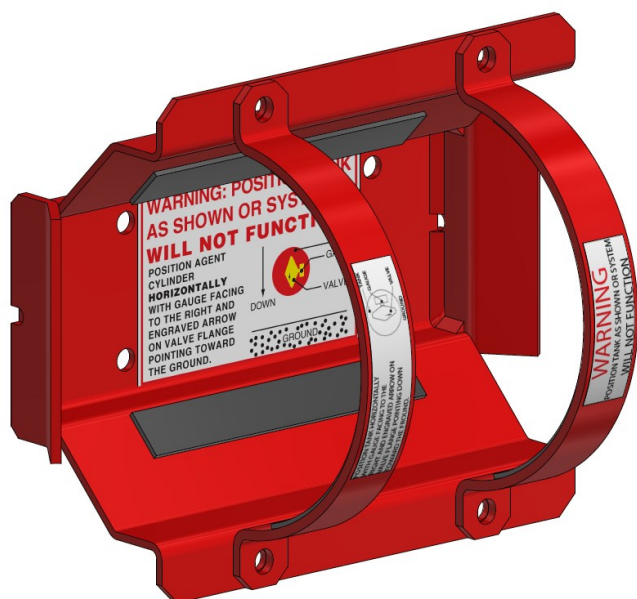

P/N: 11338

VS Cylinder Brackets are Zinc Primed and Red Powder Coated to prevent damage and extend life in highly corrosive environments. Cylinder Brackets vary depending on the size and mounting orientation for the corresponding Agent Cylinder. Dimensions are in inches [mm]. Only the specified Amerex Cylinder Bracket can be used to mount an Agent Cylinder. Use of non Amerex Cylinder Brackets is prohibited. total weight of a VH25 Cylinder and Bracket is 72 lb. (32.7 kg). Replacement bracket straps (P/N 14782) are available. A replacement bag (P/N 10244-P001) can be purchased to replace nuts, bolts, and washers.

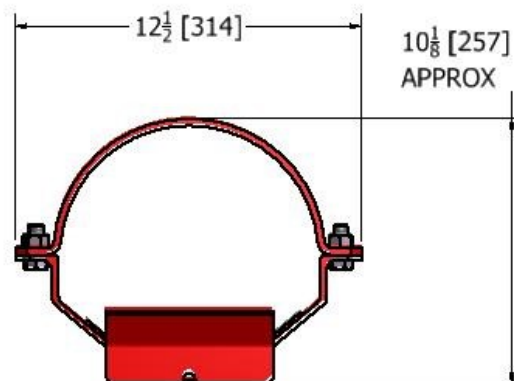
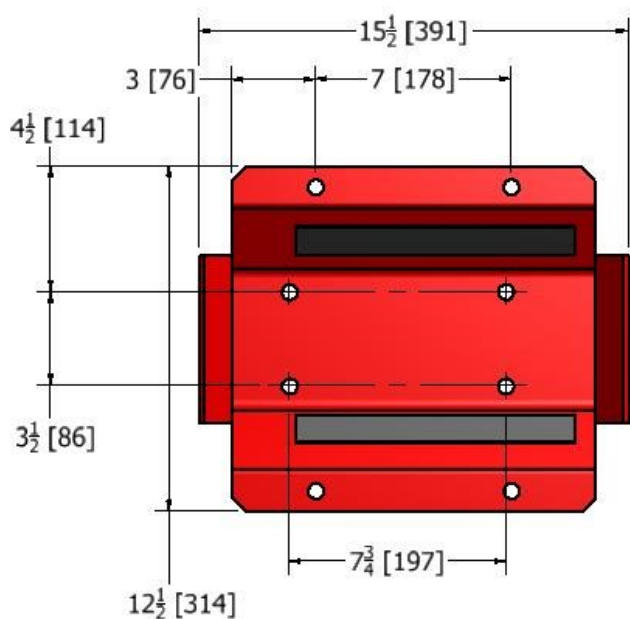



V30 BRACKET



P/N: 23259

VS Cylinder Brackets are Zinc Primed and Red Powder Coated to prevent damage and extend life in highly corrosive environments. Cylinder Brackets vary depending on the size and mounting orientation for the corresponding Agent Cylinder. Dimensions are in inches [mm]. Only the specified Amerex Cylinder Bracket can be used to mount an Agent Cylinder. Use of non Amerex Cylinder Brackets is prohibited. The total weight of a V30 Cylinder and Bracket is 90 lb. (40.8 kg). Replacement bracket straps (P/N 14782) are available. A replacement bag (P/N 10244-P001) can be purchased to replace nuts, bolts, and washers.

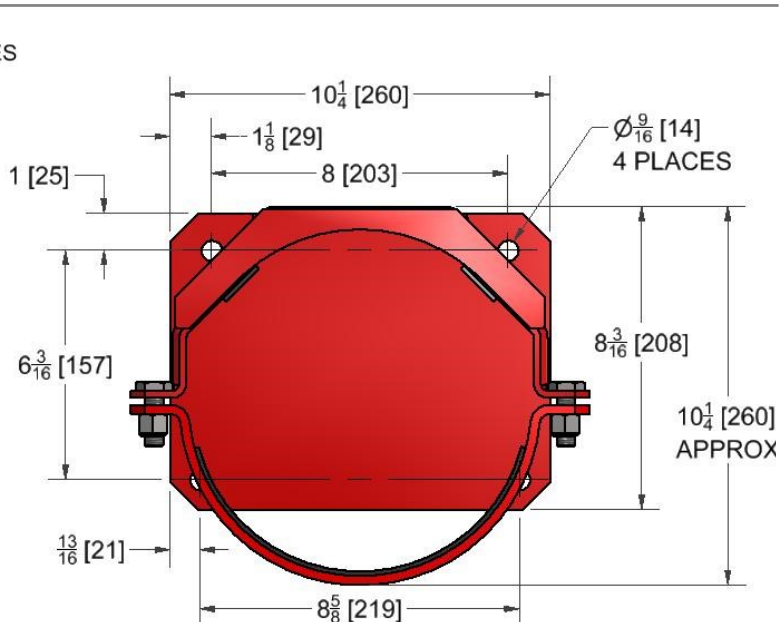
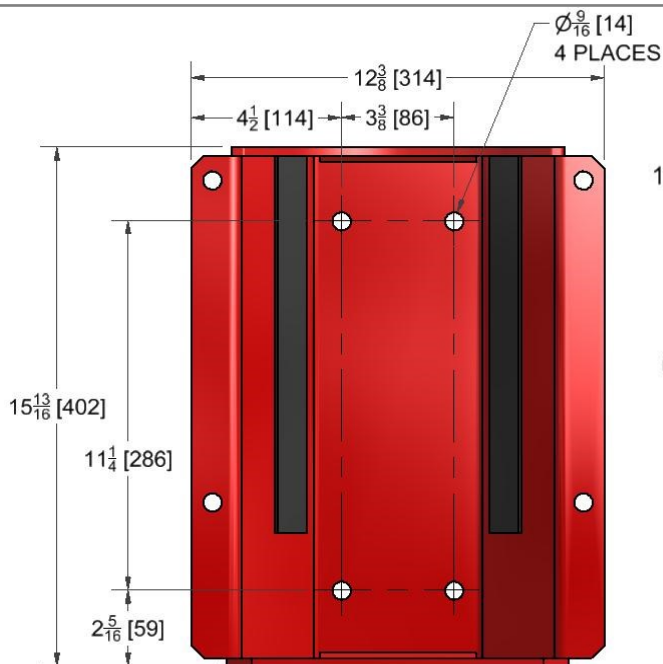



VH30 BRACKET



P/N: 22685

VS Cylinder Brackets are Zinc Primed and Red Powder Coated to prevent damage and extend life in highly corrosive environments. Cylinder Brackets vary depending on the size and mounting orientation for the corresponding Agent Cylinder. Dimensions are in inches [mm]. Only the specified Amerex Cylinder Bracket can be used to mount an Agent Cylinder. Use of non Amerex Cylinder Brackets is prohibited. The total weight of a VH30 Cylinder and Bracket is 88 lb. (39.9 kg). Replacement bracket straps (P/N 14782) are available. A replacement bag (P/N 10244-P001) can be purchased to replace nuts, bolts, and washers.

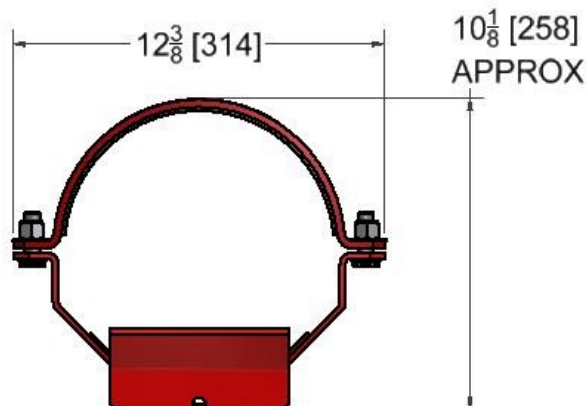
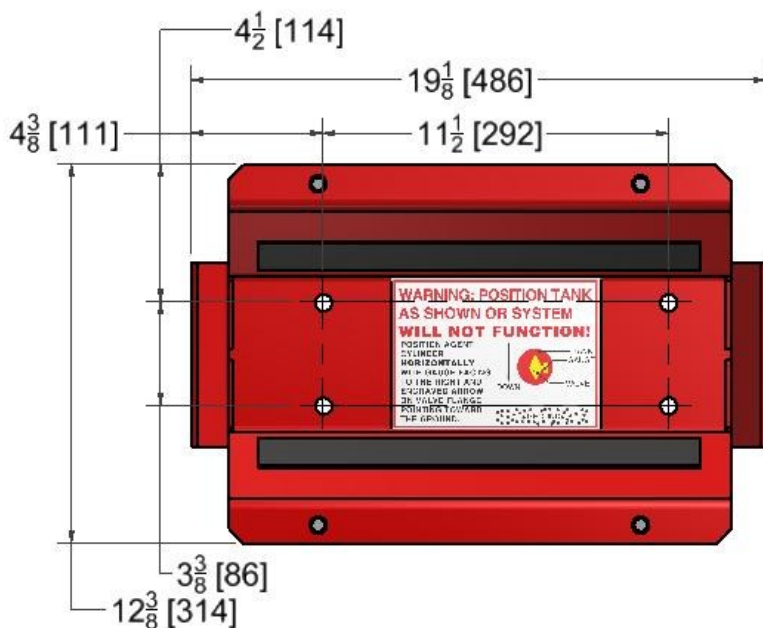



V50 BRACKET



P/N: 10181

VS Cylinder Brackets are Zinc Primed and Red Powder Coated to prevent damage and extend life in highly corrosive environments. Cylinder Brackets vary depending on the size and mounting orientation for the corresponding Agent Cylinder. Dimensions are in inches [mm]. Only the specified Amerex Cylinder Bracket can be used to mount an Agent Cylinder. Use of non Amerex Cylinder Brackets is prohibited. The total weight of a V50 Cylinder and Bracket is 138 lb. (62.6 kg). Replacement bracket straps (P/N 14782) are available. A replacement bag (P/N 10244-P001) can be purchased to replace nuts, bolts, and washers.

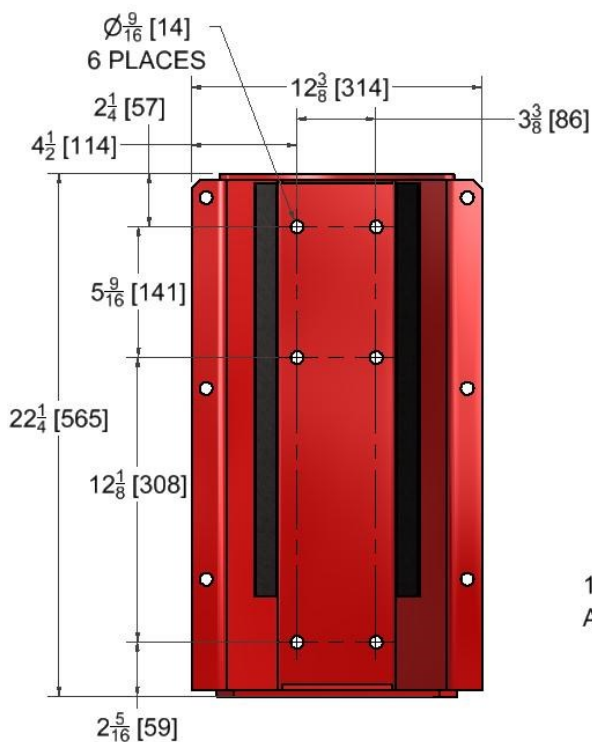



VS50 BRACKET

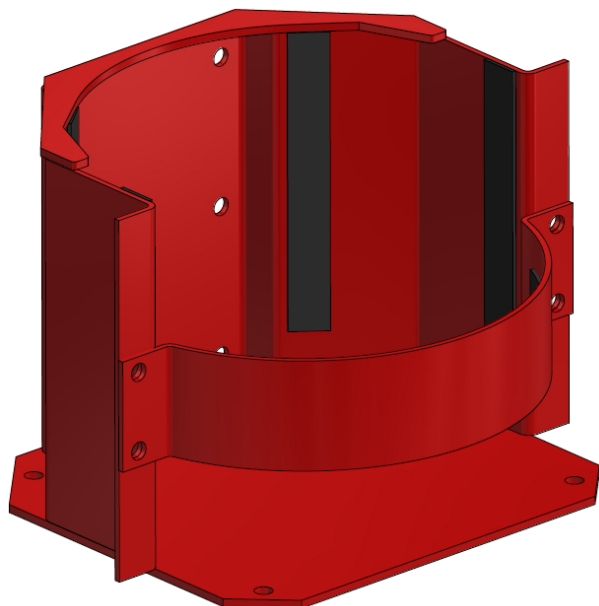

P/N: 16974

VS Cylinder Brackets are Zinc Primed and Red Powder Coated to prevent damage and extend life in highly corrosive environments. Cylinder Brackets vary depending on the size and mounting orientation for the corresponding Agent Cylinder. Dimensions are in inches [mm]. Only the specified Amerex Cylinder Bracket can be used to mount an Agent Cylinder. Use of non Amerex Cylinder Brackets is prohibited. The total weight of a VS50 Cylinder and Bracket is 144 lb. (65.3 kg). Replacement bracket straps (P/N 22220) are available. A replacement bag (P/N 10244-P001) can be purchased to replace nuts, bolts, and washers.

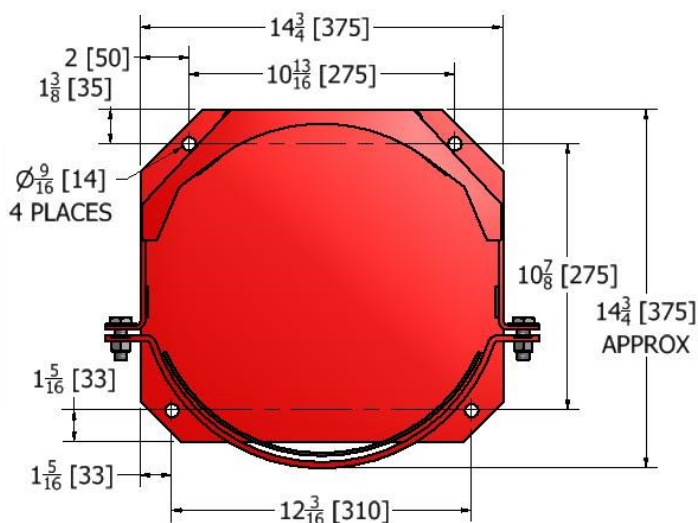
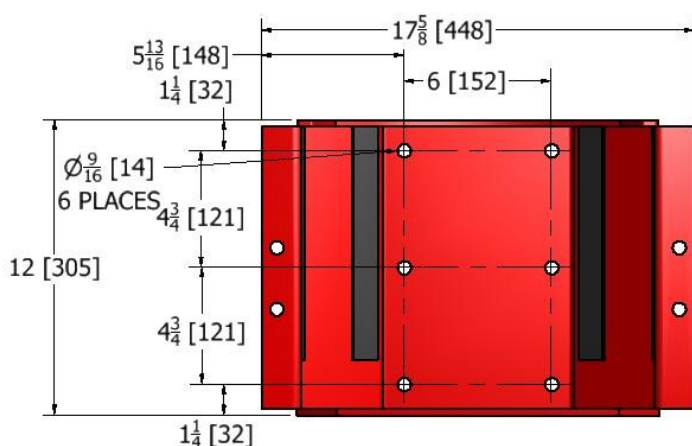



VS75 BRACKET

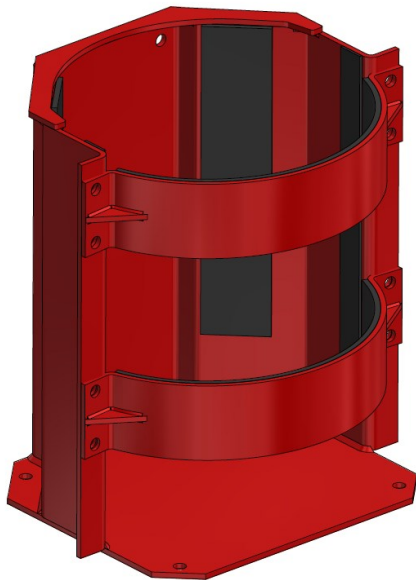

P/N: 22260

VS Cylinder Brackets are Zinc Primed and Red Powder Coated to prevent damage and extend life in highly corrosive environments. Cylinder Brackets vary depending on the size and mounting orientation for the corresponding Agent Cylinder. Dimensions are in inches [mm]. Only the specified Amerex Cylinder Bracket can be used to mount an Agent Cylinder. Use of non Amerex Cylinder Brackets is prohibited. The total weight of a VS75 Cylinder and Bracket is 205 lb.. (93 kg). Replacement bracket straps (P/N 27393) are available. A replacement bag (P/N 10244-P001) can be purchased to replace nuts, bolts, and washers.

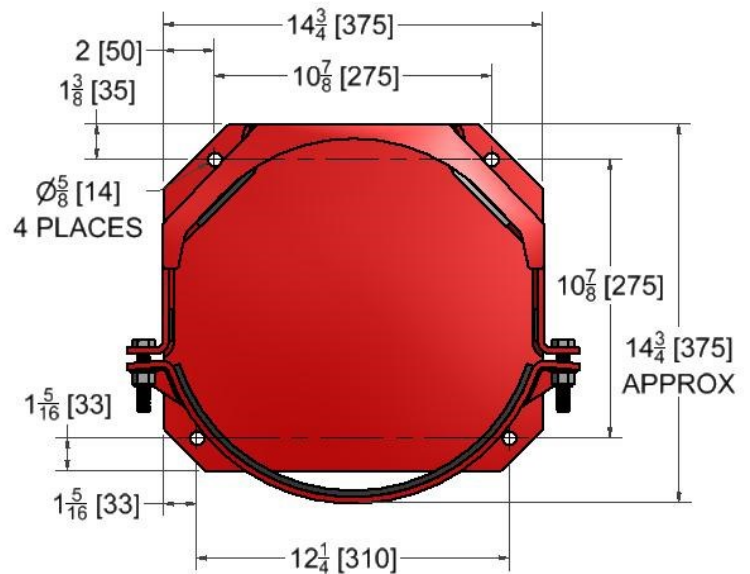
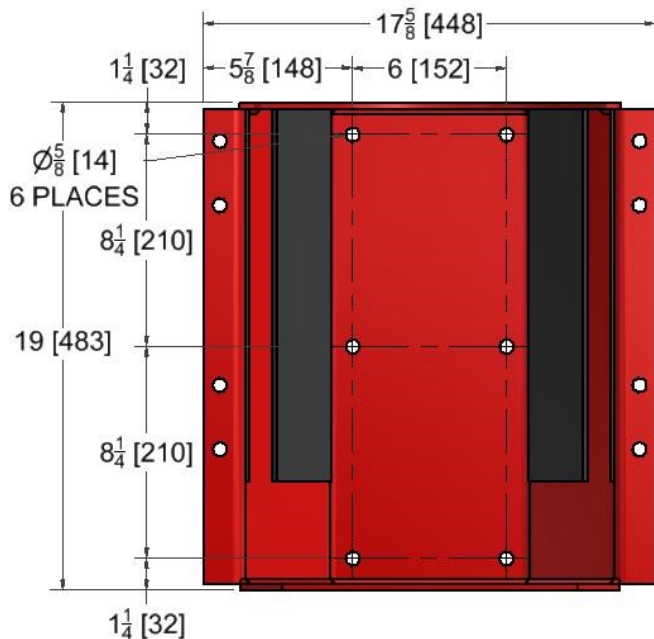



WELD RINGS

P/N: 23406

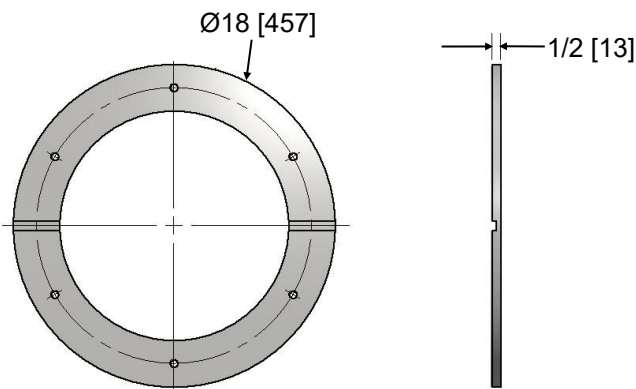

**VSR50/VSR75 Weld Ring for
 VSR50 & VSR75 Cylinder**

P/N: 22966

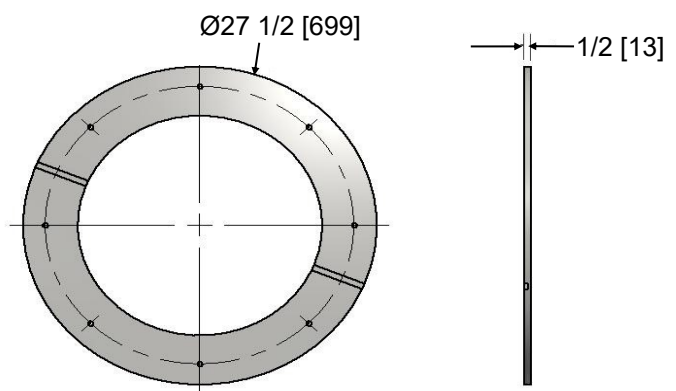

**V250 Weld Ring for
 V250 Cylinder**

The Amerex VSR50, VSR75, and V250 Agent Cylinders are constructed with heavy gauge steel and are designed with a bolting flange on the foot ring. The bolting flange allows for securing the Agent Cylinders to a horizontal surface with the use of either the VSR50/VSR75 Weld Ring (P/N 23406) or the V250 Weld Ring (P/N 22966) for their respective cylinders. The Weld Ring must be welded to a horizontal surface and oriented such that a drain hole is on the lowest point of the horizontal surface. Fillet weld all around entire outer edge of Weld Ring, EXCEPT across the drain holes. VSR50/VSR75 Fasteners (P/N 23404) to secure the VSR50 or VSR75 Agent Cylinder to the Weld Ring or V250 Fasteners (P/N 22925) to secure the V250 Agent Cylinder are supplied with the Weld Ring. Dimensions are in inches [mm].





COMBINED CYLINDER & BRACKET WEIGHT

Agent Cylinder	Cylinder Bracket	Cylinder P/N	Maximum Total Weight, lb. (kg)
V13	V13 Cylinder Bracket	12156	45 (20.4)
V25	V25 Cylinder Bracket	10180	74 (33.6)
VH25	VH25 Cylinder Bracket	11338	72 (32.7)
V30	V30 Cylinder Bracket	23259	90 (40.8)
VH30	VH30 Cylinder Bracket	22685	88 (39.9)
V50	V50 Cylinder Bracket	10181	138 (62.6)
VS50	VS50 Cylinder Bracket	16974	144 (65.3)
VS75	VS75 Cylinder Bracket	22260	205 (93.0)
VSR50	VSR50/VSR75 Weld Ring	23406	139 (63.0)
VSR75			188 (85.3)
V250	V250 Weld Ring	22966	575 (260.8)





DISCHARGE FITTING KIT

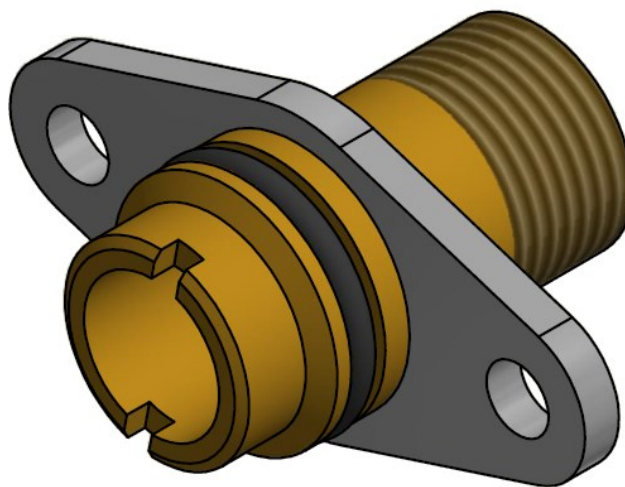

P/N: 10199

The Discharge Fitting Kit is used to connect the Agent Cylinder Valve to the Agent Distribution Network. It consists of a brass fitting with an O-ring seal on one end and 3/4" NPT male pipe threads on the other, and a stainless steel flange for locking the fitting in place. The flange is placed over the threaded end of the fitting before connection to the Agent Distribution Network.





DISTRIBUTOR BLOCK: 3/4" X 1/2"

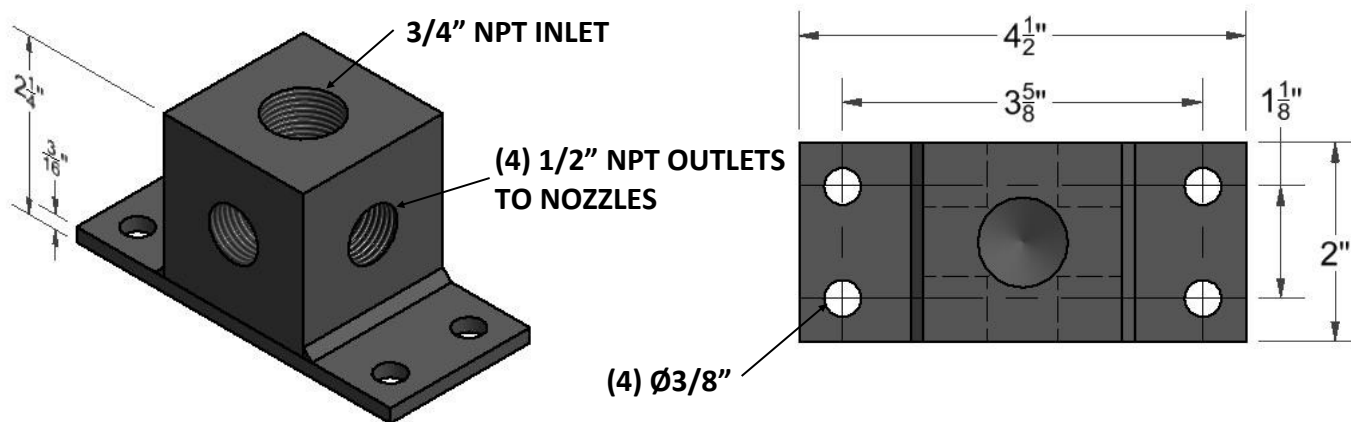

P/N: 10178

The Distributor Block 3/4" X 1/2" is used in the Agent Distribution Network to distribute the flow of Dry Chemical Agent to multiple nozzles. It has one inlet with 3/4" NPT threaded port, and four outlets with 1/2" NPT threaded ports. The Distributor Block is painted black to inhibit corrosion.





DISTRIBUTOR BLOCK: 3/4" X 3/4"

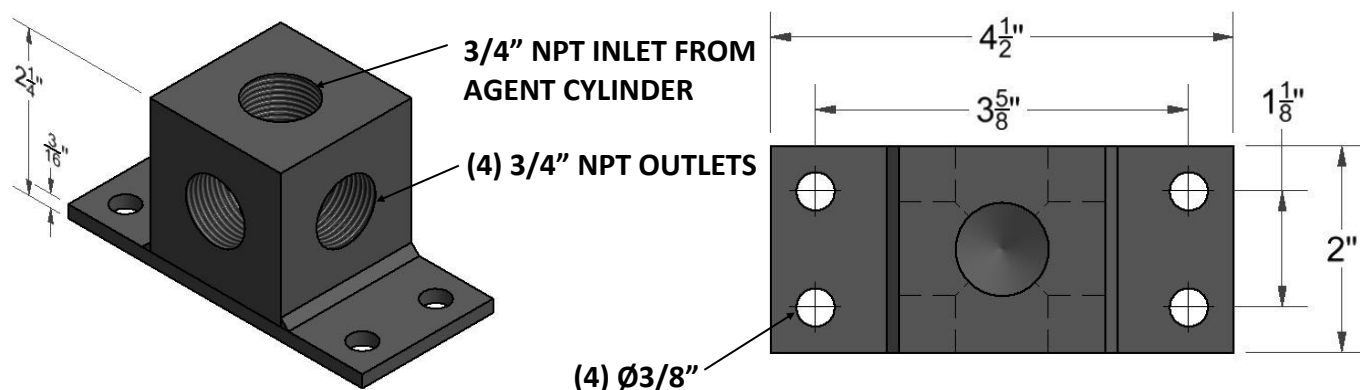

P/N: 10178

The Distributor Block 3/4" X 3/4" is used in the Agent Distribution Network to distribute the flow of Dry Chemical Agent. It has one inlet with 3/4" NPT threaded port, and four outlets with 3/4" NPT threaded ports. The Distributor Block is painted black to inhibit corrosion.





DISTRIBUTOR BLOCK: 1-1/4" X 3/4"

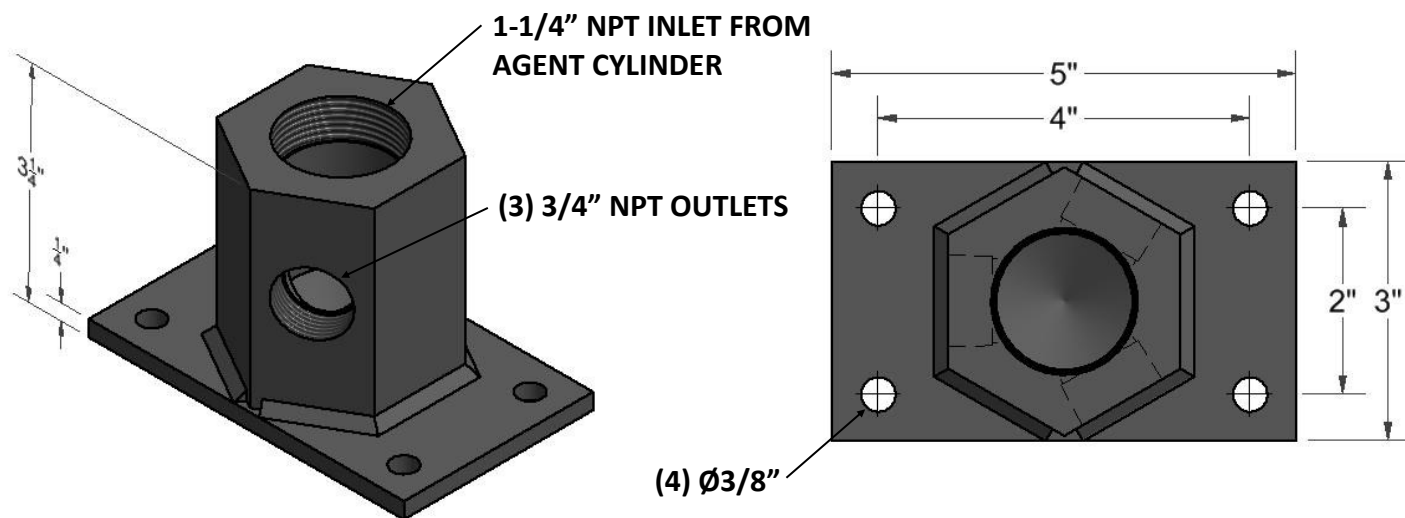

P/N: 22853

The Distributor Block 1-1/4" X 3/4" is used in the Agent Distribution Network to distribute the flow of Dry Chemical Agent. It has one inlet with 1-1/4" NPT threaded port, and three outlets with 3/4" NPT threaded ports. The Distributor Block is painted black to inhibit corrosion.





DISTRIBUTOR BLOCK: 1-1/4" X 3/4"

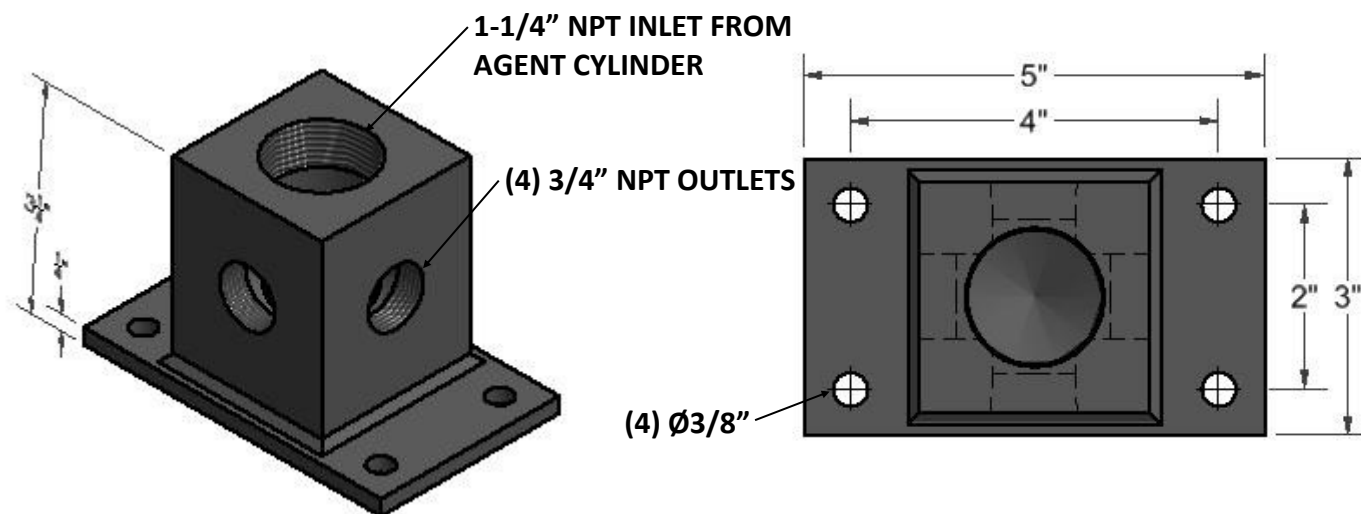

P/N: 22856

The Distributor Block 1-1/4" X 3/4" is used in the Agent Distribution Network to distribute the flow of Dry Chemical Agent. It has one inlet with 1-1/4" NPT threaded port, and four outlets with 3/4" NPT threaded ports. The Distributor Block is painted black to inhibit corrosion.





DISTRIBUTOR BLOCK: 3/4" X 1/2"

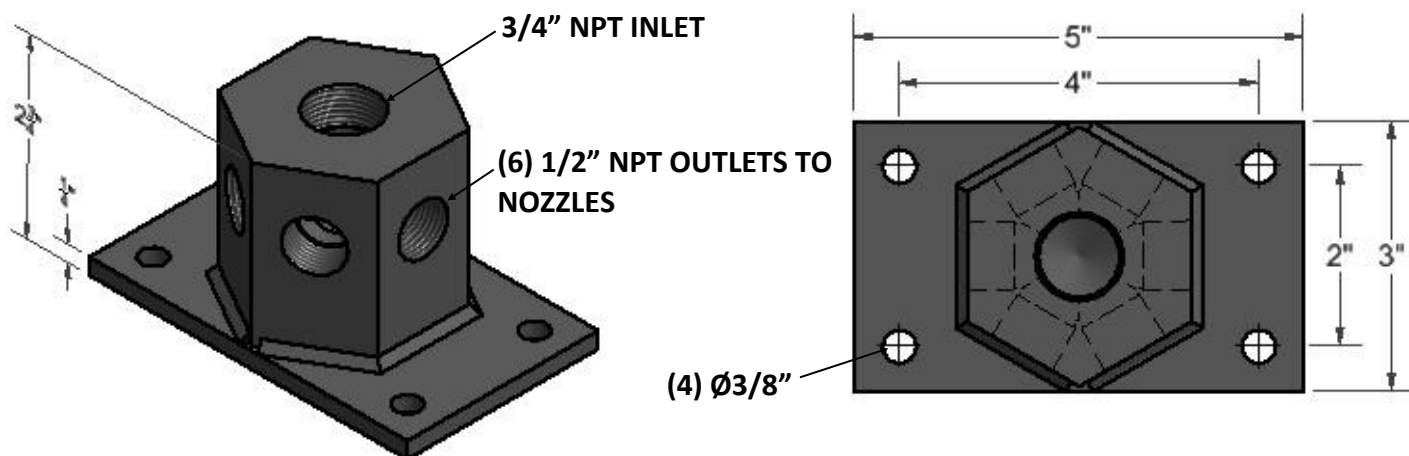

P/N: 22698

The Distributor Block 3/4" X 1/2" is used in the Agent Distribution Network to distribute the flow of Dry Chemical Agent. It has one inlet with 3/4" NPT threaded port, and six outlets with 1/2" NPT threaded ports. The Distributor Block is painted black to inhibit corrosion.





NOZZLE BRACKET

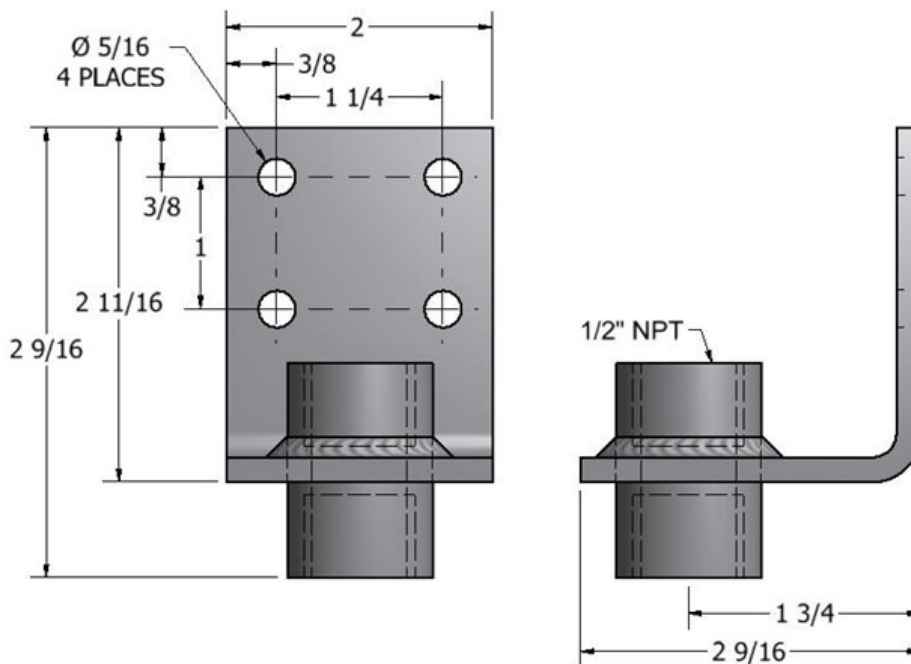

P/N: 10780

Nozzle Brackets are used to connect the Agent Distribution Network to the Nozzles as well as support the Nozzles once mounting locations are determined. Nozzle Brackets are a 90° angle with a welded 1/2" NPT coupler. All Nozzle Brackets are painted black to inhibit corrosion.





DISCHARGE NOZZLE

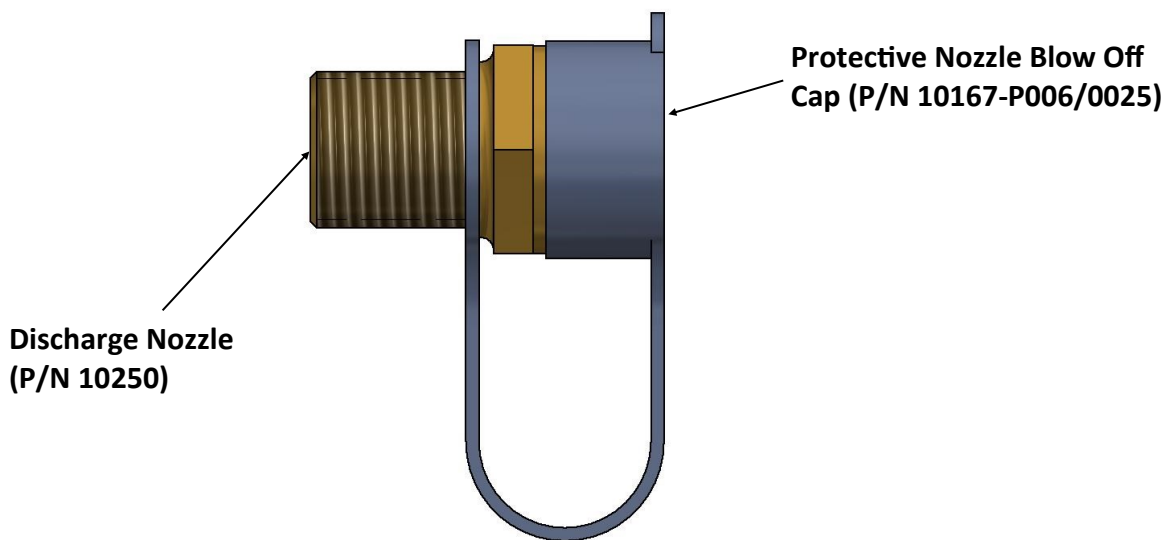

P/N: 10250

The Discharge Nozzle is used for dispersing Dry Chemical Agent in a cone shaped pattern into the hazard area. It is constructed of brass and is machined with a 1/2" NPT male thread. It is shipped with a heat and weather resistant rubber Protective Nozzle Blow-Off Cap (P/N 10167) that prevents debris from lodging in the Nozzle outlet. The blow off cap is molded with a retaining loop that assembles over the 1/2" NPT threads before the Nozzle is installed. Replacement Nozzle Blow Off Caps are available (P/N 10167).





ELECTRIC CONTROL HEAD

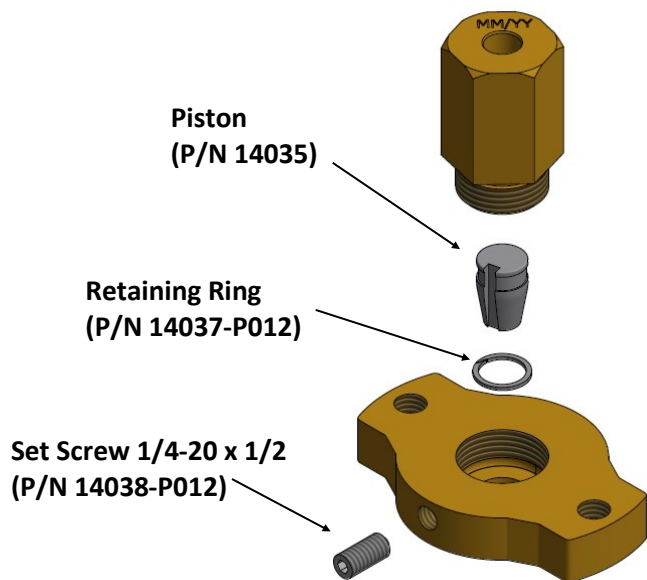
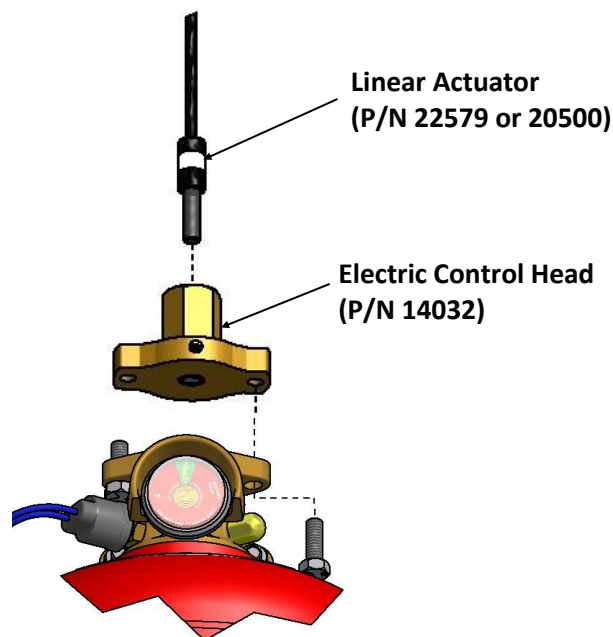
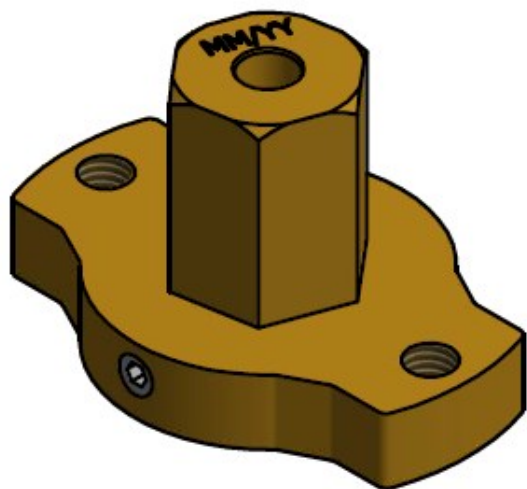

P/N: 14032

The Electric Control Head is used in all electrically only actuated Amerex Dry Chemical System installations. This device is constructed of machined brass and bolts directly to the top of the Agent Cylinder Valve. The body of the Electric Control Head is threaded to accept a Linear Actuator (P/N 22579 or 20500). The base retains the actuator piston and locking ring. The Linear Actuator, when activated, will force the piston inside the Electric Control Head down to depress the Agent Cylinder Valve stem, releasing the Dry Chemical Agent.





ELECTRIC / PNEUMATIC CONTROL HEAD

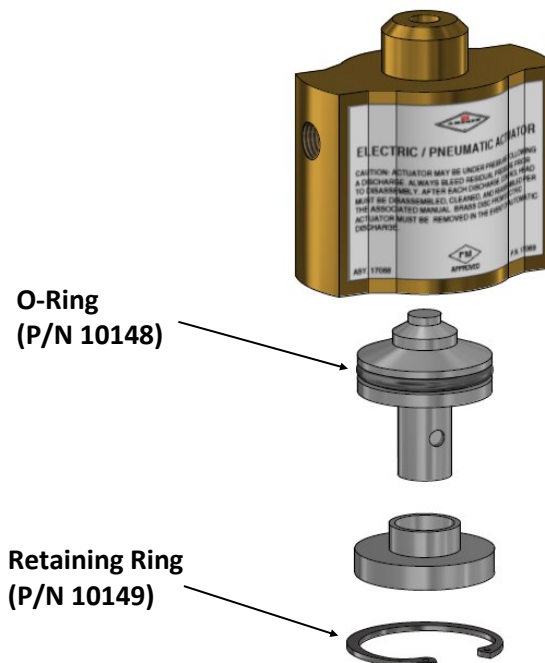
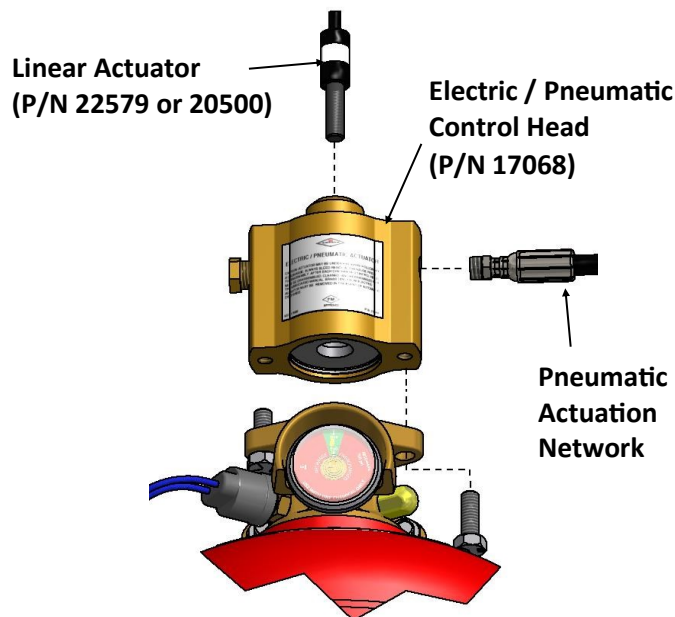

P/N: 17068

The Electric / Pneumatic Control Head offers two methods to actuate the Amerex Dry Chemical System. One method is to manually discharge the system using pressure from a Nitrogen Cylinder of a remote Manual Actuator through the Pneumatic Actuation Network. The second method is to discharge the system with use of an electrically actuated Linear Actuator. The Electric / Pneumatic Control Head is constructed of extruded brass and bolts directly to the top of the Agent Cylinder Valve. When supplied with nitrogen pressure from the Pneumatic Actuation Network through 1/4" NPT female ports on either side, the piston inside the Electric / Pneumatic Control Head extends and depresses the Agent Cylinder Valve stem, releasing the Dry Chemical Agent. The top of the Electric / Pneumatic Control Head has a threaded hole that accepts the Linear Actuator (P/N 22579 or 20500). The Linear Actuator, when activated, will force the piston inside the Electric / Pneumatic Control Head down to depress the Agent Cylinder Valve stem, releasing the Dry Chemical Agent.





PNEUMATIC CONTROL HEAD

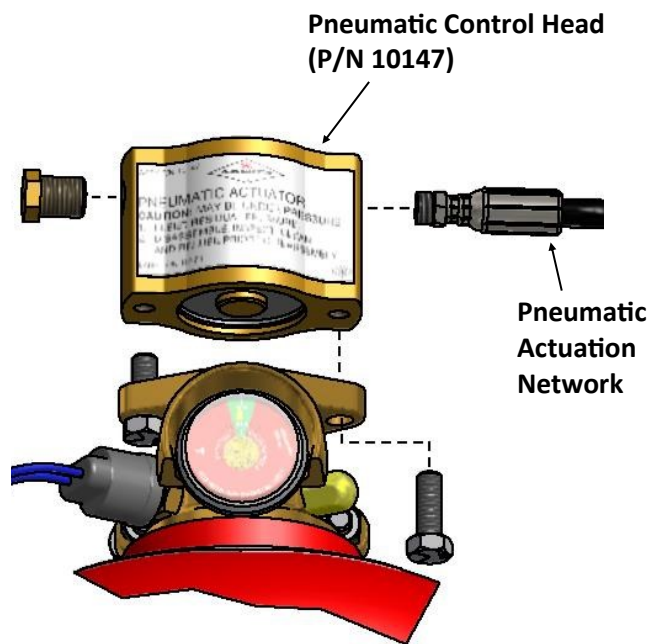

Pneumatic Act Label (P/N 10724)



O-Ring (P/N 10148)

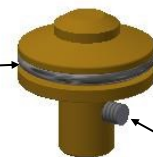

Push in to reset

Retaining Ring (P/N 10149)

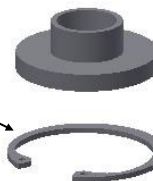

P/N: 10147

The Pneumatic Control Head is used in all pneumatic only actuated Dry Chemical System installations using a remote Manual, Electric Nitrogen or Manual/Electric Actuator through the Pneumatic Actuation Network. This device is constructed of extruded brass and bolts directly to the top of the Agent Cylinder Valve. When supplied with nitrogen actuation pressure from the Pneumatic Actuation Network through 1/4" NPT female ports on either side, the piston inside the Pneumatic Control Head extends and depresses the Agent Cylinder Valve stem, releasing the Dry Chemical Agent.





ELECTRIC / PNEUMATIC CONTROL HEAD: V250

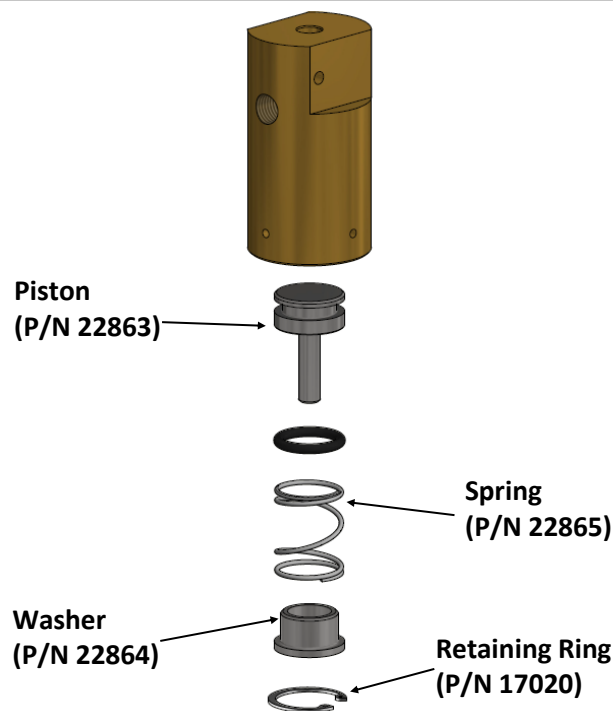
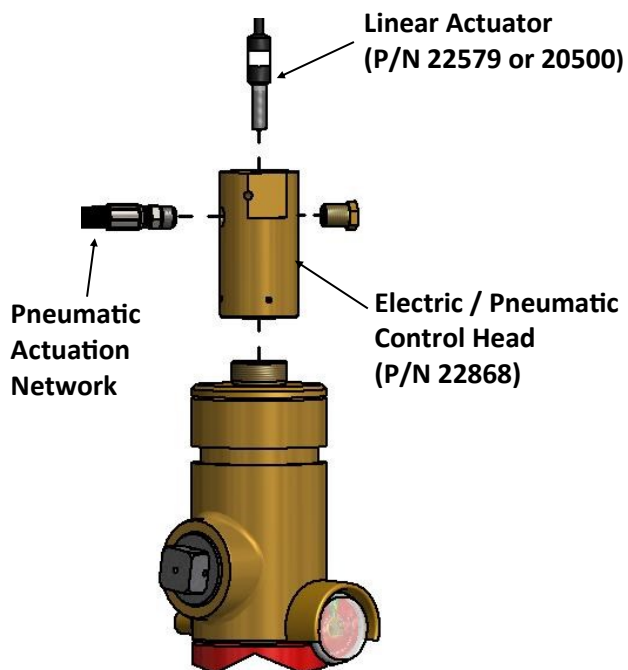

P/N: 22868

The V250 Electric / Pneumatic Control Head offers two methods to actuate the Amerex Dry Chemical System. One method is to manually discharge the system using pressure from a Nitrogen Cylinder of a remote Manual Actuator through the Pneumatic Actuation Network. The second method is to discharge the system with use of an electrically actuated Linear Actuator. The Electric / Pneumatic Control Head is constructed of extruded brass and threads directly on the top of the Agent Cylinder Valve. When supplied with nitrogen pressure from the Pneumatic Actuation Network through 1/4" NPT female ports on either side, the piston inside the V250 Electric / Pneumatic Control Head extends and depresses the Schrader valve in the Agent Cylinder Valve, releasing the Dry Chemical Agent. The top of the V250 Electric / Pneumatic Control Head has a threaded hole that accepts a Linear Actuator (P/N 22579 or 20500). The Linear Actuator, when activated, will force the piston inside the V250 Electric / Pneumatic Control Head down, releasing the Dry Chemical Agent.





PNEUMATIC CONTROL HEAD: V250

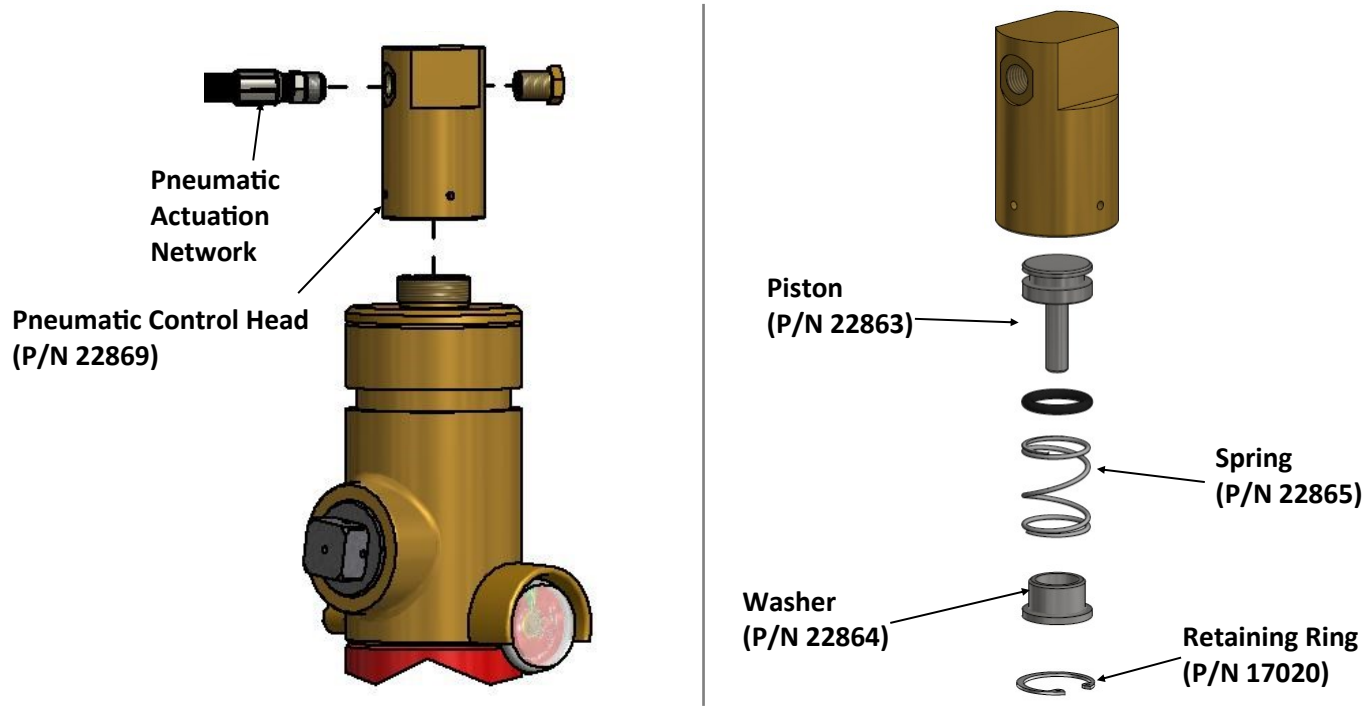

P/N: 22869

The V250 Pneumatic Control Head is used in all pneumatic only actuated Dry Chemical System installations using a remote Manual, Electric Nitrogen or Manual/Electric Actuator through the Pneumatic Actuation Network. This device is constructed of extruded brass and threads directly to the top of the Agent Cylinder Valve. When supplied with nitrogen actuation pressure from the Pneumatic Actuation Network through 1/4" NPT female ports on either side, the piston inside the V250 Pneumatic Control Head extends and depresses the Schrader Valve in the top of the Agent Cylinder Valve, releasing the Dry Chemical Agent.





VENT PLUG

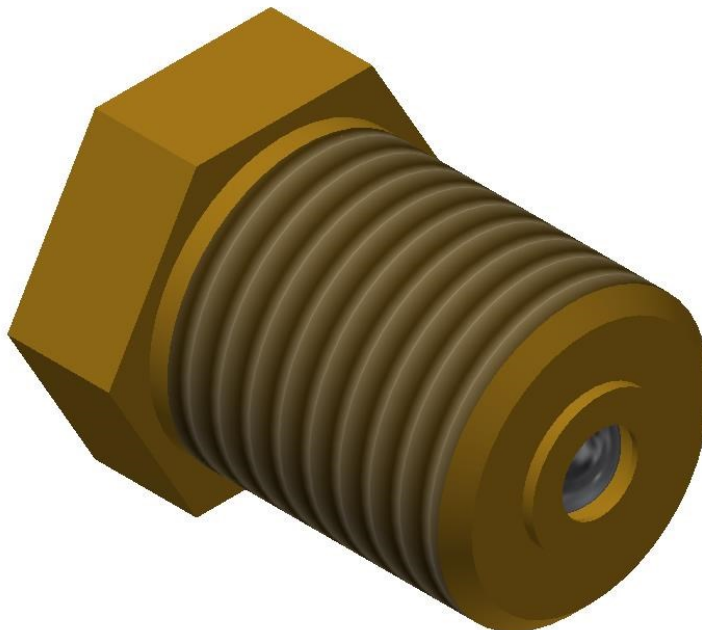

P/N: 10173

The Vent Check is a safety device that installs in the Pneumatic Control Head or the Electric / Pneumatic Control Head. Its function is to relieve any slowly accumulating pressure that could cause the control head to open the Agent Cylinder Valve prematurely. A Vent Check must be used on all systems that utilize nitrogen pressure for activation of the Amerex Modular Dry Chemical Fire Suppression System. The body of the Vent Check is constructed of machined brass. The inside of the Vent Check contains a spring and nylon ball. The Vent Check is supplied with a plastic Dust Cap (P/N 13761-P006, NOT PICTURED), which must be installed on the Vent Check after installation into the Pneumatic Control Head and/or the Electric / Pneumatic Control Head.





LINEAR ACTUATOR

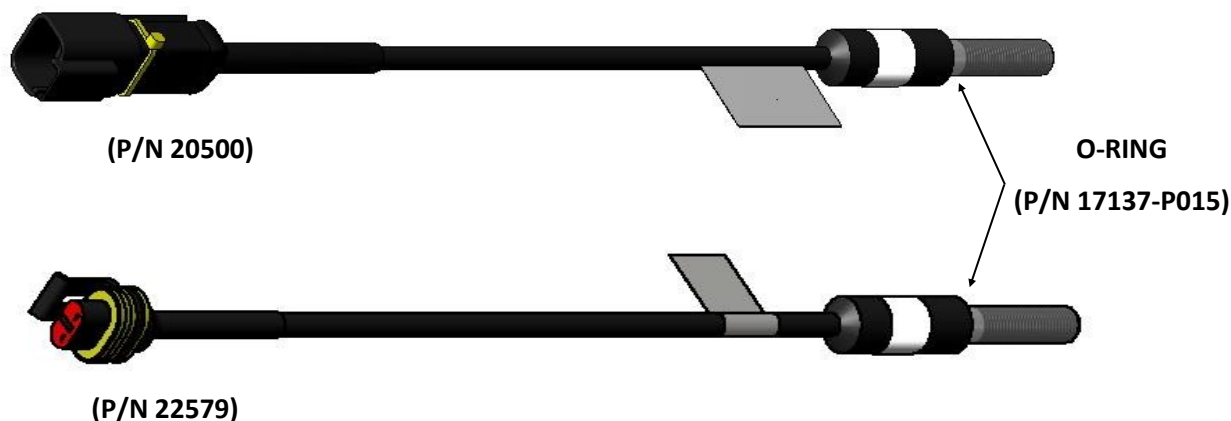

P/N: 22579 & 20500

The Linear Actuator is a device when electrically activated extends a metal shaft which mechanically opens the Agent Cylinder Valve when used in a control head or opens a Nitrogen Cylinder when used in an Electric Nitrogen Actuator. Once activated it cannot be reused and must be replaced. Service life of the Linear Actuator is 6 years after which it must be replaced. Shelf life of the Linear Actuator is 10 years after which it must be replaced whether it has been placed in service or not. Each Linear Actuator is supplied with a Mylar style label for identifying date of manufacture. An O-Ring (P/N 17137-P015) is provided with each Linear Actuator, and must be used each time that a Linear Actuator is installed. Select the appropriate Linear Actuator for use with the vehicle's Amerex Modular Electronics System





LINEAR ACTUATOR SPLITTER

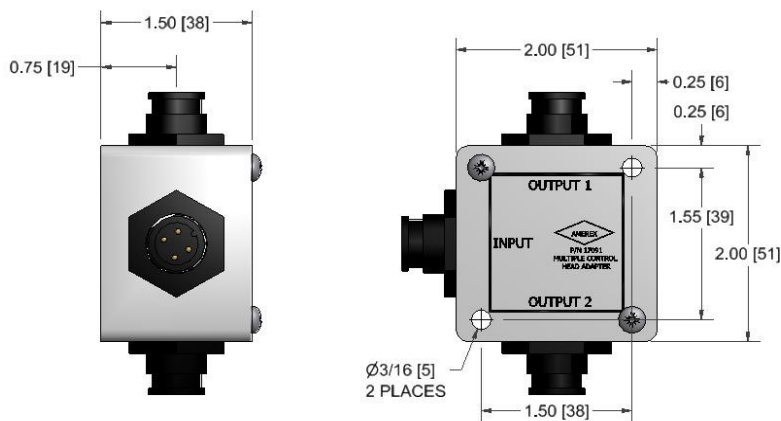

**Two Way Linear Actuator
 (P/N 17091)**

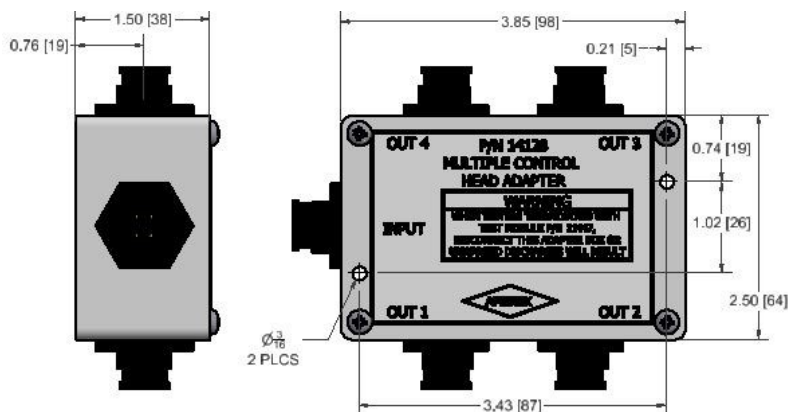

**Four Way Linear Actuator
 (P/N 14128)**

P/N: 17091 & 14128

The two or four way linear actuator splitter connects to the actuation circuit of the Amerex circuit monitor and the control panel to allow for up to four linear actuators. In the event of a alarm condition, all linear actuators will be activated.





ELECTRIC NITROGEN ACTUATOR

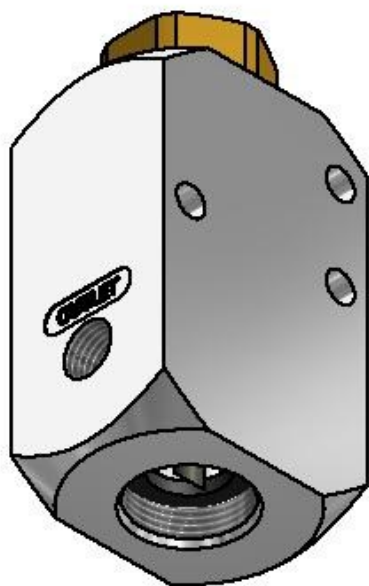

P/N: 20775

The Electric Nitrogen Actuator is used to release nitrogen gas pressure from a Nitrogen Cylinder to pneumatically activate a control head through a Pneumatic Actuation Network. The body of the Electric Nitrogen Actuator is constructed of chrome plated brass and contains a stainless steel puncture point and a 1/4" NPT female port to connect to the Pneumatic Actuation Network. A brass adapter is threaded into the top that accepts a Linear Actuator (P/N 22579 or 20500). The Electric Nitrogen Actuator is supplied with two 1/4"-20 stainless steel cap screws (P/N 10573-P012) for securing the assembly to an Actuator Bracket.

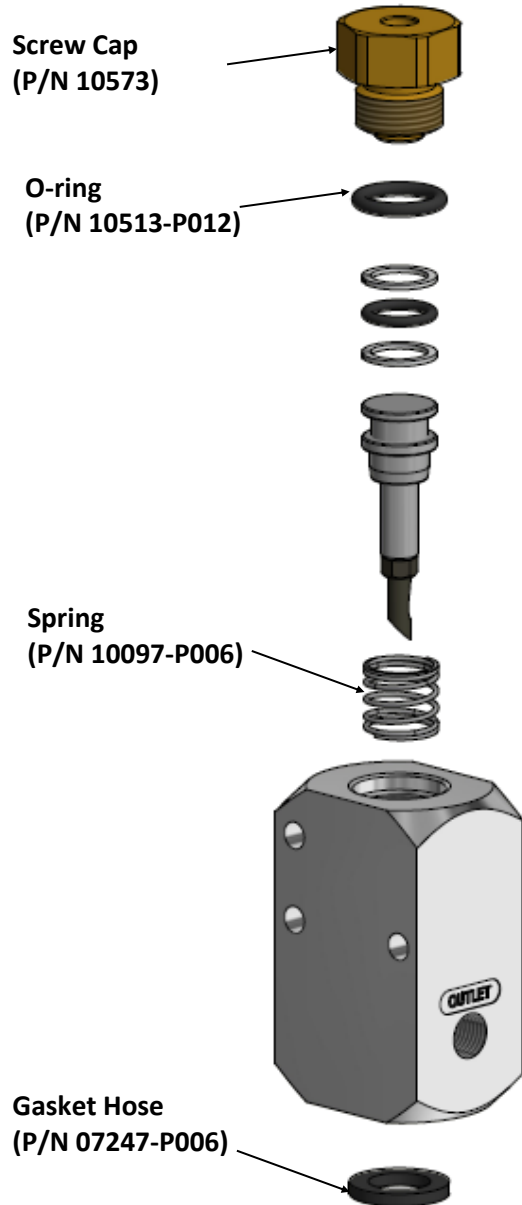



MANUAL NITROGEN ACTUATOR

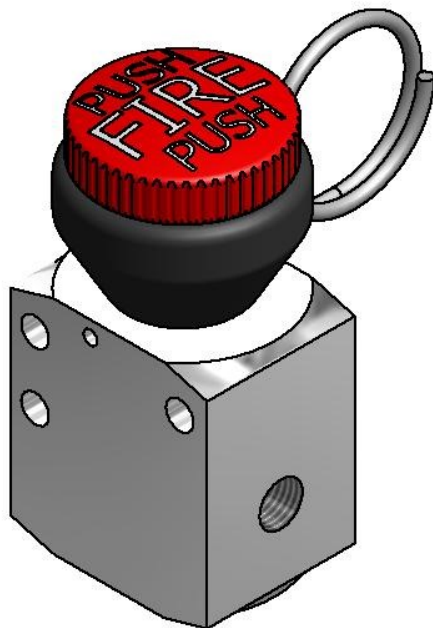

P/N: 10210

The Manual Actuator is used to manually release nitrogen gas pressure from a Nitrogen Cylinder to pneumatically activate a control head through a Pneumatic Actuation Network. The body of the Manual Actuator is chrome plated brass and contains a stainless steel puncture point that is connected to a palm button and locked in place by a stainless steel ring pin. It also contains a 1/4" NPT female port to connect to the Pneumatic Actuation Network. The exposed shaft of the stem is shielded from the elements by a rubber dust boot. The Manual Actuator is supplied with two 1/4"-20 stainless steel cap screws (P/N 10573-P012) for securing the assembly to an Actuator Bracket.

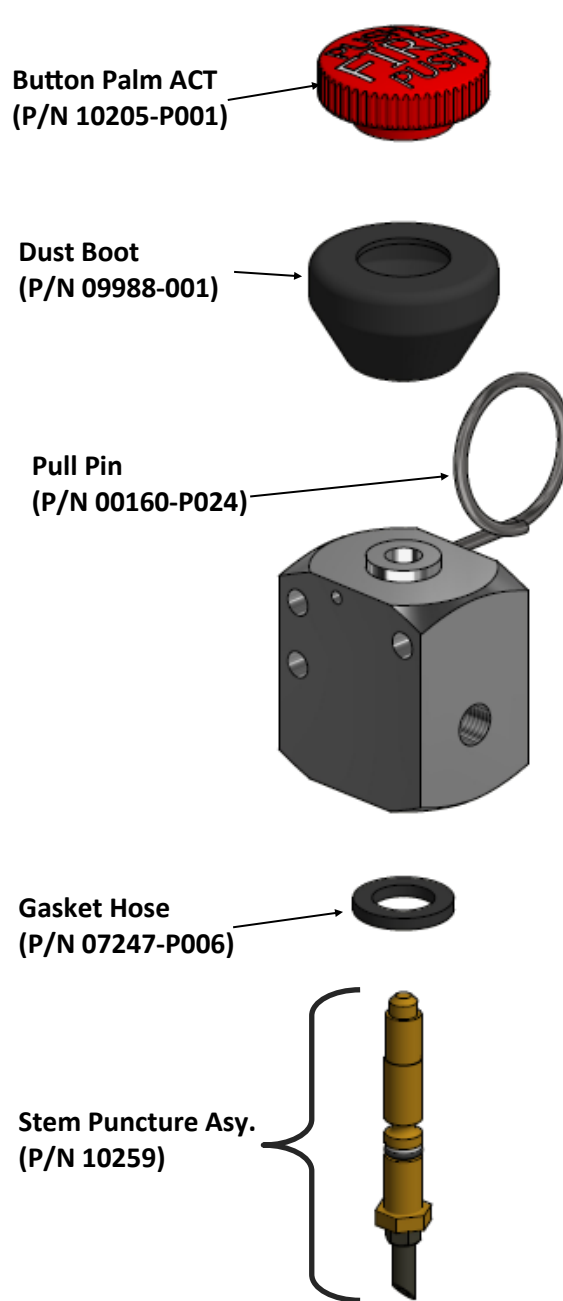



ELECTRIC / MANUAL NITROGEN ACTUATOR

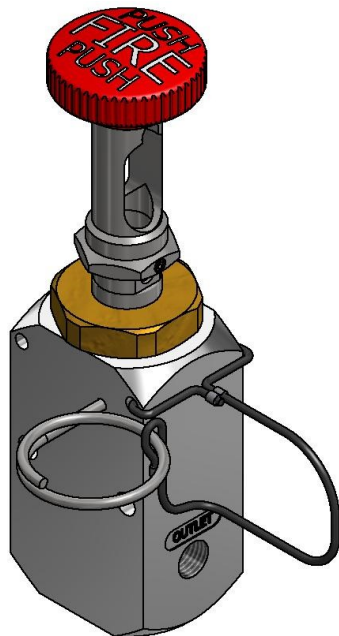

P/N: 23600

The Manual/Electric Actuator is used to manually or electrically release nitrogen gas pressure from a Nitrogen Cylinder to pneumatically activate a control head through a Pneumatic Actuation Network. The body of the Manual Actuator is chrome plated brass and contains a stainless steel puncture point and upper shaft. This upper shaft contains a palm button, locked in place by a stainless steel ring pin, and also accepts a Linear Actuator (P/N 22579 or 20500). A 1/4" NPT female port is used to connect to the Pneumatic Actuation Network. The Manual/Electric Actuator is supplied with two 1/4"-20 stainless steel cap screws (P/N 10573-P012) for securing the assembly to an Actuator Bracket.

Button Palm ACT
 (P/N 10205-P001)



Spring
 (P/N 10097-P006)



Pull Pin
 (P/N 00160-P024)



Gasket Hose
 (P/N 07247-P006)





ACTUATOR BRACKET

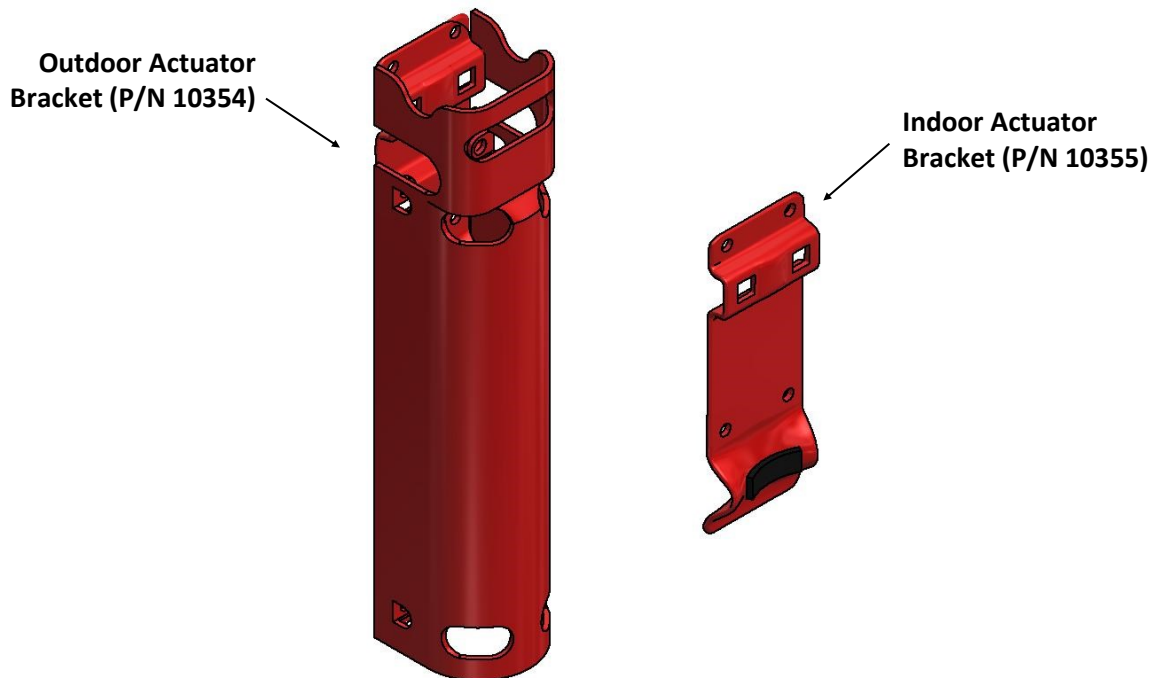

P/N: 10354 & 10355

The Manual Actuator, Electric Nitrogen Actuator, and Nitrogen Cylinder can be mounted to the vehicle with use of an Indoor Actuator Bracket (P/N 10355) or an Outdoor Actuator Bracket (P/N 10354). Both brackets are constructed of steel and painted to inhibit corrosion. The Outdoor Actuator Bracket includes a steel guard to protect the actuator and Nitrogen Cylinder.





NITROGEN ACTUATION CYLINDER

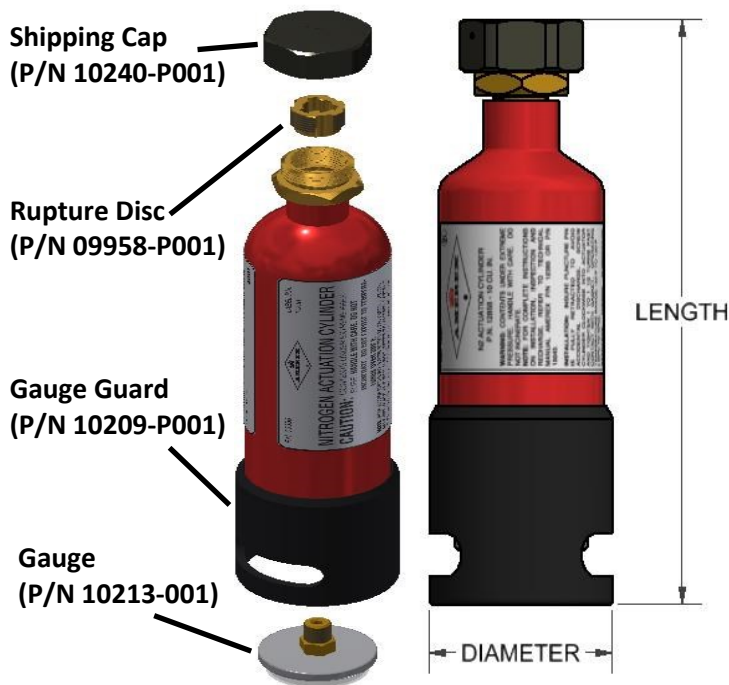

Part No.	09956 (15 in ³)	
Diameter	1.998 in	5.07 cm
Length	9 11/25 in	24 cm

Typical Pressure	09956	
@ 40° F	~1700 PSI	~11722 kPa
@ 70° F	1800 PSI	12411 kPa
@ 100° F	~1900 PSI	~12893 kPa

P/N: 09956

The Nitrogen Cylinder supplies nitrogen gas pressure to a control head through the Pneumatic Actuation Network to open the Agent Cylinder Valve. The Nitrogen Cylinder is charged to 1800 psi (12410 kPa) at 70°F (21°C). A pressure gauge is used to identify proper charge pressure of the Nitrogen Cylinder, and is located on the bottom of the Nitrogen Cylinder. The pressure gauge is protected by an impact resistant plastic gauge guard. The Nitrogen Cylinder is shipped fully charged from the Amerex factory with a protective shipping cap installed on the outlet threads. The cap must be removed at installation but must remain in place at all other times. Retain the shipping cap to reuse when recharging a Nitrogen Cylinder. Construction of the Nitrogen Cylinder is per DOT 3E. The cylinder is rechargeable by certified Amerex installers and does not require periodic hydro testing.

A Replacement Rupture Disc is available for use by certified Amerex installers when recharging.





ACTUATION CHECK VALVE

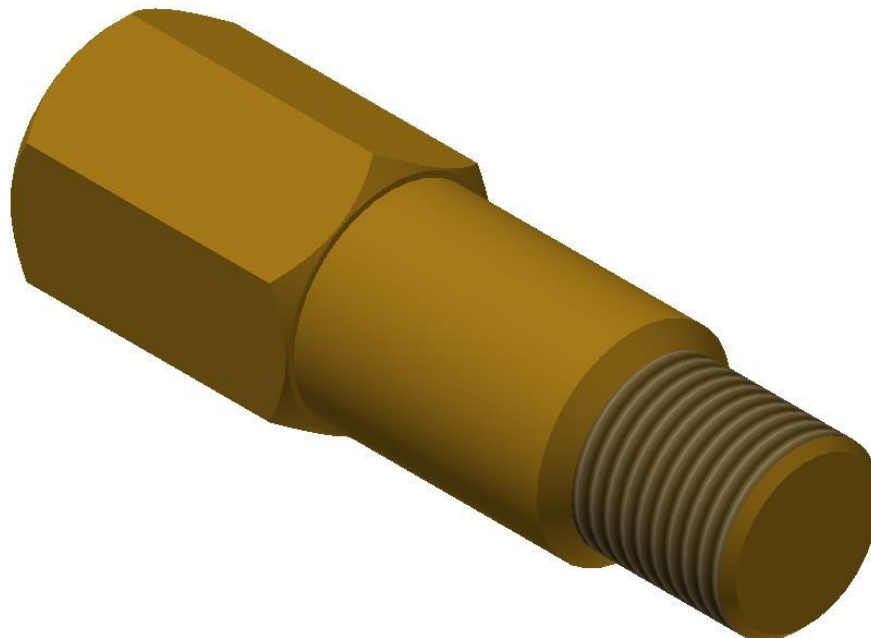

P/N: 10262

The Check Valve is made of brass material and is required in various locations of the Pneumatic Actuation Network to ensure that the nitrogen gas flows along the correct path to the control head(s). Although more than one actuation circuit can converge in the Pneumatic Actuation Network, each circuit must have an independent path from either a Manual, Electric Nitrogen, or Manual/Electric Actuator to the Agent Cylinder control head. This can be accomplished with use of the Check Valve. Direction of flow must be with nitrogen going into the 1/4" NPT female port and out of the 1/4" NPT male port.





PRESSURE SWITCH: 50 PSI



P/N: 22573, 22574, & 23850

The 50 PSI Pressure Switch is designed to be used in the Pneumatic Actuation Network of a vehicle system. The Switch (P/N 22573 non-terminated version; P/N 22574 w/ AMP connectors; P/N 23850 w/ Deutsch connectors) is normally in the open position and closes when subjected to nitrogen pressure in excess of 50 PSI. The Switch is threaded with a 1/4" NPT male port. The Switch must be installed in a tee in the Pneumatic Actuation Network just before the first Pneumatic (P/N 10147), or Electric / Pneumatic (P/N 17068) Control Head. The Switch can be utilized to send a signal such as "system discharge" back to the associated electronics panel, or to an external relay for sounding an auxiliary alarm or illuminating a light in the event of system discharge.

The switch has an electrical rating of 40 VDC / 3 amp resistive, 120 to 240 VAC / 3 amp resistive.





CIRCUIT MONITOR



P/N: 17309 & 17308

The circuit monitor can operate up to two detection zones and one releasing zone. The choices for detection are spot heat detectors, linear heat detectors, remote manual actuation buttons. The 50 PSI switch can also be connected in the detection circuit to signal the panel of a pneumatic manual actuation, but does not act as a heat detection device. These class B devices can be used in any combination by connecting in series. An end of line module (EOL) is always required at the end of the class B circuit. All detection cables and components are color coded green.





CIRCUIT MONITOR DIMENSIONAL DATA

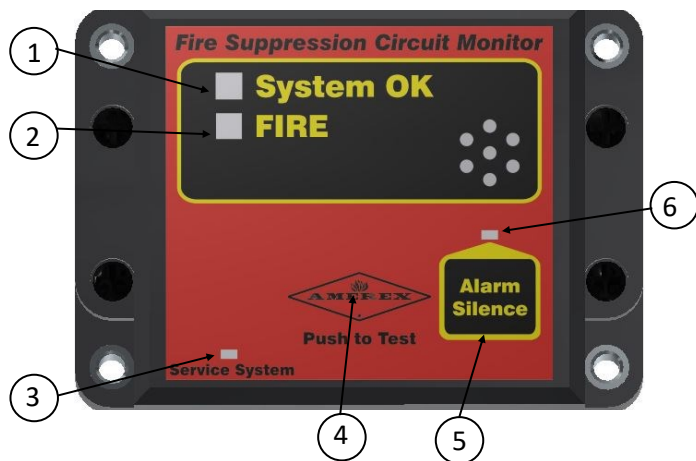

Circuit Monitor Features	
1	System OK LED
2	Fire LED
3	Service System LED
4	Push to Test Button
5	Alarm Silence Button
6	Alarm Silenced LED

P/N: 17309 & 17308

The Circuit Monitor allows for surface or flush mount applications and wires routed from the back (P/N 17309) or from the bottom (P/N 17308). All dimensions are in inches [mm].

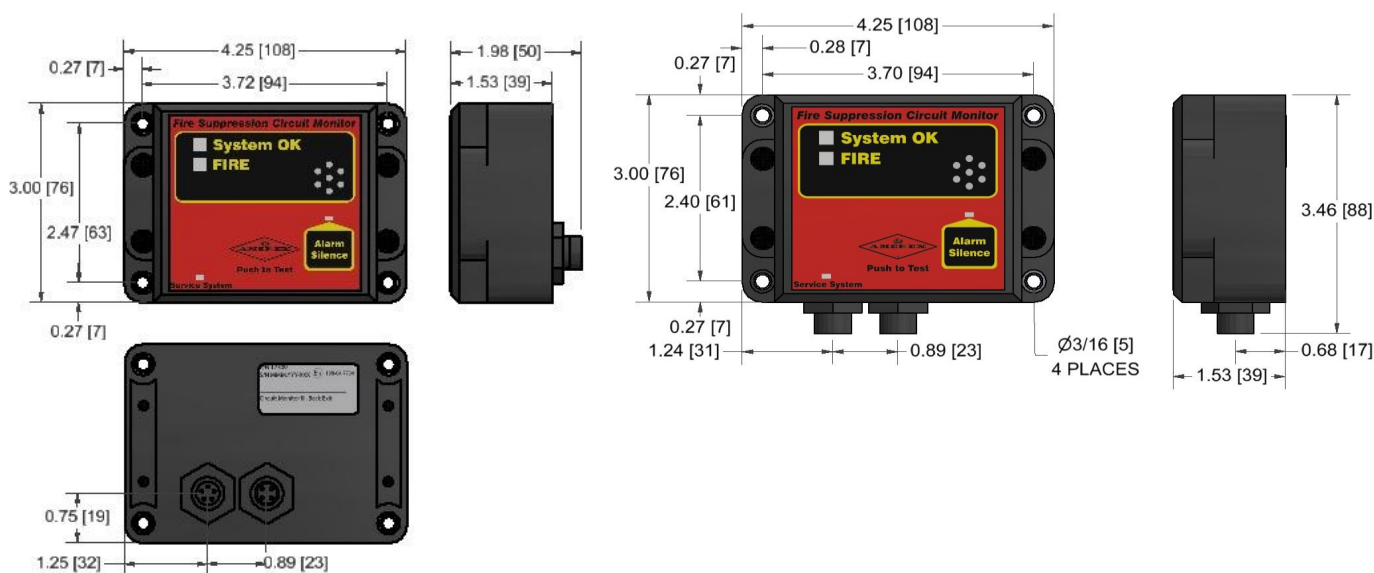



CONTROL PANEL



P/N: 17310 & 17311

The Control Panel is of the same design as the Circuit Monitor, but with an added agent cylinder pressure monitoring circuit and fire relay output signal. The Control Panel can operate up to two detection zones and one releasing zone. The choices for detection are spot heat detectors, linear heat detectors, remote manual actuation buttons. The 50 PSI switch can also be connected in the detection circuit to signal the panel of a pneumatic manual actuation, but does not act as a heat detection device. These class B devices can be used in any combination by connecting in series. An end of line module (EOL) is always required at the end of the class B circuit. All detection cables and components are color coded green.





CONTROL PANEL DIMENSIONAL DATA

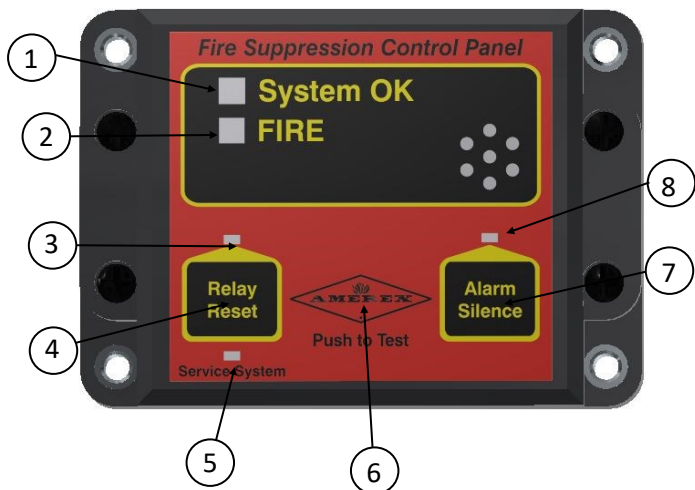

Control Panel Features	
1	System OK LED
2	Fire LED
3	Relay Engaged LED
4	Relay Reset Button
5	Service System LED
6	Push to Test Button
7	Alarm Silence Button
8	Alarm Silenced LED

P/N: 17310 & 17311

The Control Panel allows for surface or flush mount applications and wires routed from the back (P/N 17311) or from the bottom (P/N 17310). All dimensions are in inches [mm].

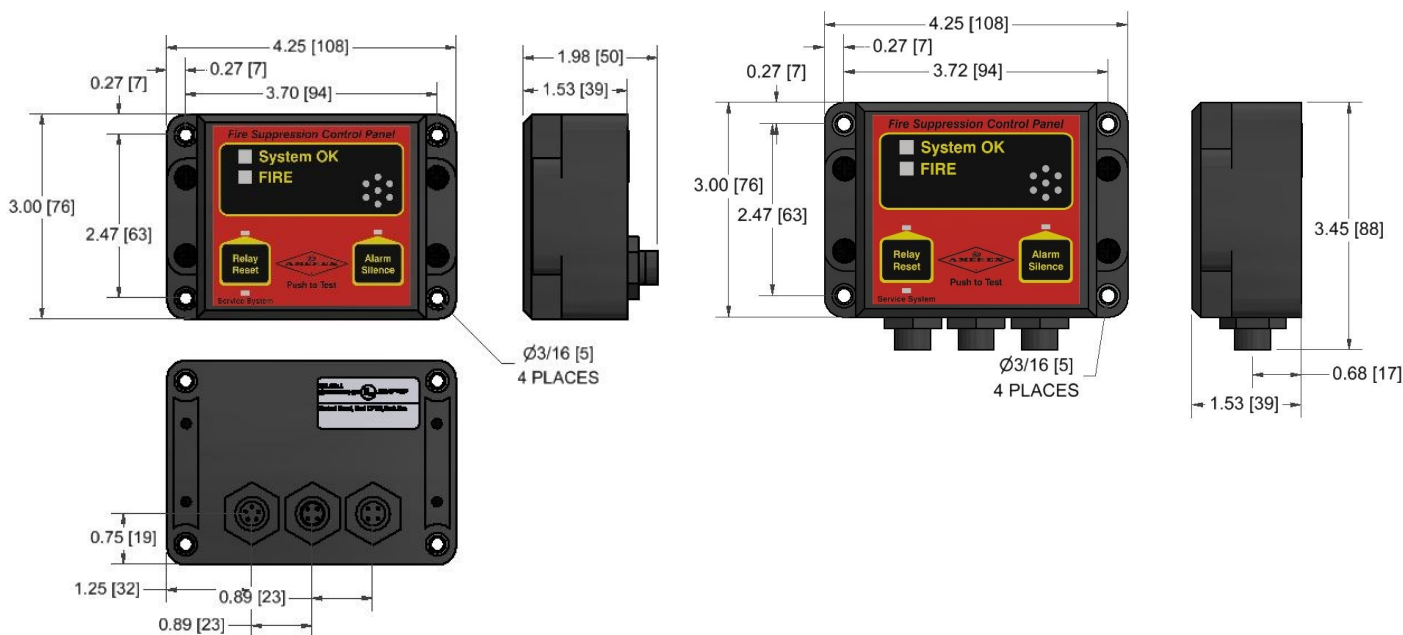



SAFETYNET OPERATOR DISPLAY PANEL

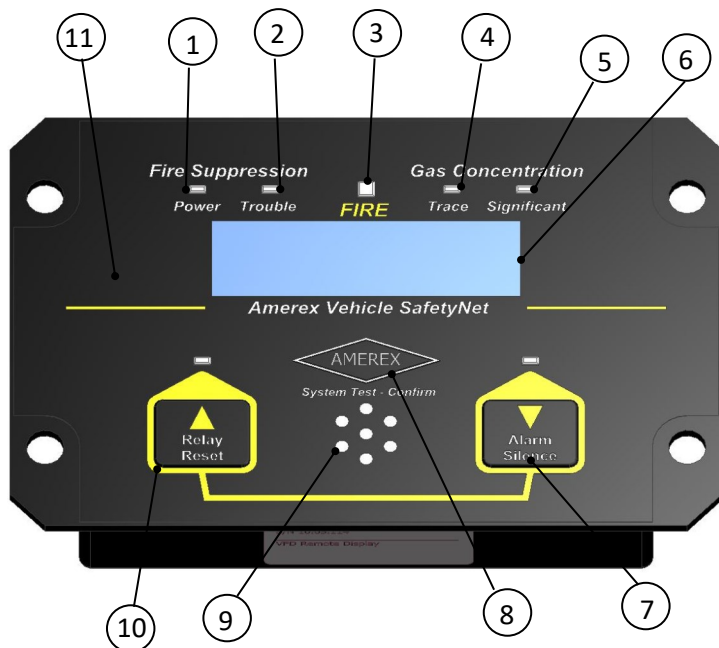

SafetyNet Operator Display Panel Features	
1	System Power - Green LED
2	System Trouble - Yellow LED
3	Fire Indication - Red LED
4	Trace Gas - Yellow LED
5	Significant Gas - Red LED
6	Vacuum Florescent Display VFD
7	Alarm Silence Button & Red LED
8	Push to Test & System
8	Confirmation Switch
9	Audible Alarm
10	Relay Reset & Red LED
11	Ambient Light Sensor

P/N: 16389

The Amerex vehicle SafetyNet operator’s display panel indicates vehicle fire suppression system status to the vehicle operator or maintenance personnel. Basic system status is indicated via LEDs and audible alarm indications. Detailed “Event” text messages are shown on the panel display. The Operator’s display panel functions as the central control of other system modules.





SAFETYNET DRIVER PANEL

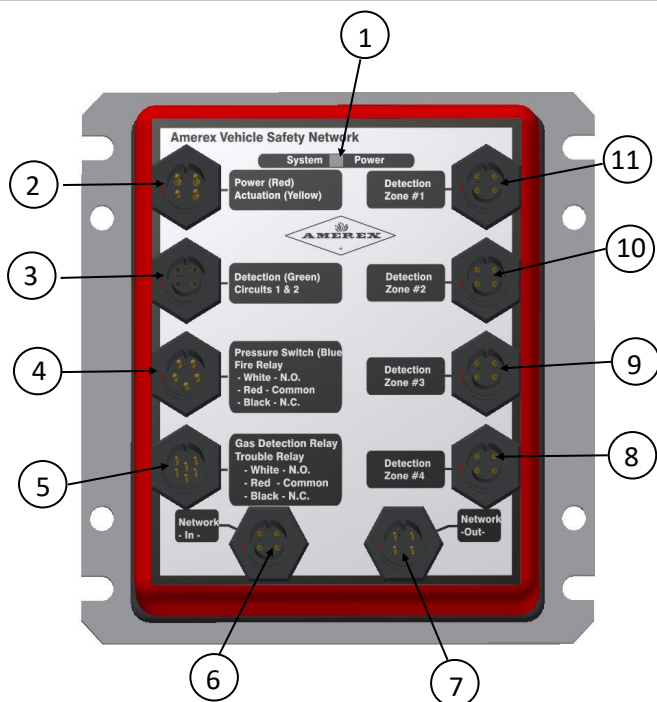

SafetyNet Driver Panel Features	
1	System power - green LED
	System trouble - yellow LED
2	System power & linear actuator
3	Class B detection & manual act. circuits
4	Pressure switch & fire relay contacts
5	Gas relay & trouble relay contacts
6	Network input
7	Network output
8	Detection zone #4
9	Detection zone #3
10	Detection zone #2
11	Detection zone #1

P/N: 16390

The Amerex Vehicle SafetyNet driver panel includes the most common features required for vehicle fire protection and gas detection systems. The driver panel is supplied with modular lead assemblies that provide connecting points for fire suppression/gas detection field wiring inputs and outputs. Connections are provided for:

System power, Fire suppression actuation, Class B heat detection devices, Manual actuation, Agent cylinder pressure supervision, Relay contacts (fire, gas, trouble), Four additional detection zones for methane gas sensors, optical flame detection and also can be used for additional class B heat detection devices, and Network output/input connectivity

While the driver panel includes most system features, the network capability of the system allows for the addition of other specific system modules. The driver panel includes battery backup for up to 24-hours of fire suppression capability in the event of system power failure. The driver panel includes sensor recognition software.





SAFETYNET DETECTION MODULE



SafetyNet Detection Module Features	
1	Network Input Connection
2	Detection Zone #1
3	Detection Zone #2
4	Detection Zone #3
5	Detection Zone #4
6	System Power & Fire Relay Contacts
7	Power LED - Green LED Trouble LED - Yellow LED
8	Network output connection

P/N: 16391

The SafetyNet Detection Module allows for zoned fire, heat or gas detection capability. The detection module can interface to: Amerex gas sensors, Safe IR optical flame detectors, Class B detection devices, and Manual actuation.

Any mix of detection types is acceptable. The detection module has the capability to automatically identify and discriminate between all of the above listed devices. A sensor alarm warning is provided to the operator display panel via a communication cable. All system sensors are monitored for proper operation. Network capability is built into the detection module allowing connection of multiple SafetyNet modules. More than one detection module may be used in a SafetyNet system.





SAFETYNET DETECTION / RELEASE MODULE

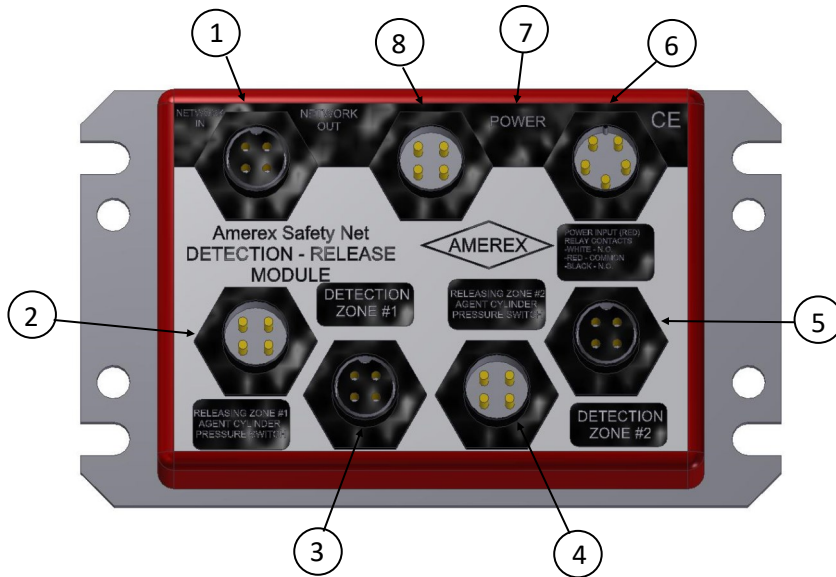

SafetyNet Detection and Releasing Module Features	
1	Network Input Connection
2	Releasing Zone #1
	Agent Cylinder Pressure Switch
3	Detection Zone #1
4	Releasing Zone #2
	Agent Cylinder Pressure Switch
5	Detection Zone #2
6	System Power & Fire Relay Contacts
7	Power LED - Green LED
	Trouble LED - Yellow LED
8	Network Output Connection

P/N: 16395

The SafetyNet Detection Releasing Module allows for zoned fire detection and releasing capability. The detection-releasing module provides an interface for: Amerex gas sensors, Safe IR optical flame detectors, Class B detection devices, Manual actuation button, and Actuation circuits/electric actuators.

Any mix of detection types is acceptable. The detection-releasing module has the capability to automatically identify and discriminate between any sensor type listed above. Sensor warning is provided to the operator display panel via a communication cable. All system sensors are monitored for proper operation. Network capability allows for connection of multiple SafetyNet modules. More than one detection-releasing module may be used in a SafetyNet system.





MANUAL ACTUATION SWITCH

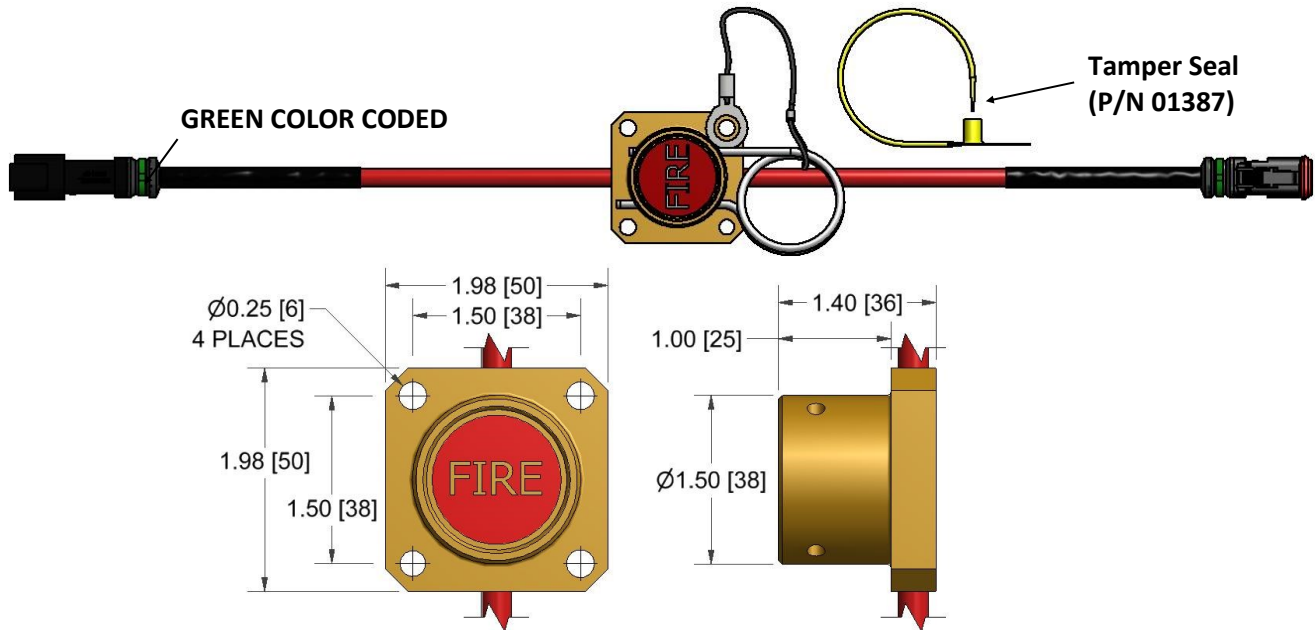

P/N: 14053

The manual actuation switch (P/N 14053) is used in the “Class B” detection circuit. The switch is in the normally open position. The switch has a red “FIRE” button that can be pressed to complete the circuit of the “Class B” circuit for activating the fire suppression system.





SPOT HEAT DETECTOR

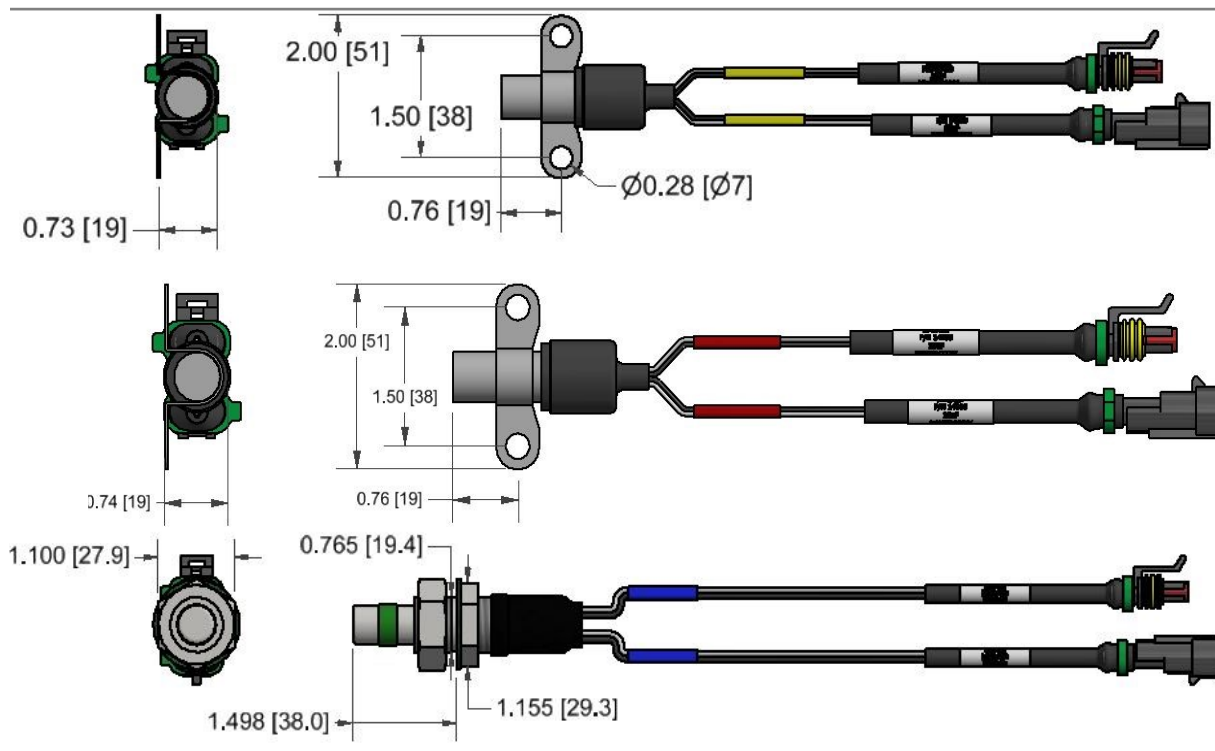

P/N: 14087, 14088, & 24680

A spot heat detector is a normally open, self resetting contact closure device. The device is configured with four wires to allow supervision of series connected circuitry. The internal contacts of the device will close upon reaching designed temperature set point parameters. Two versions of the device are available. One style of the device is supplied with a 280°F set point rating (P/N 14087) and 350°F (P/N 14088). Another style of the device is supplied with a 500°F set point rating (P/N 24680).

P/N	Set Point	Set Point Color Identification	Mounting Style
14087	280°F (137°C)	Yellow	Bracket
14088	350°F (176°C)	Red	Bracket
24680	500°F (232°C)	Blue	Bulkhead





LINEAR HEAT DETECTOR

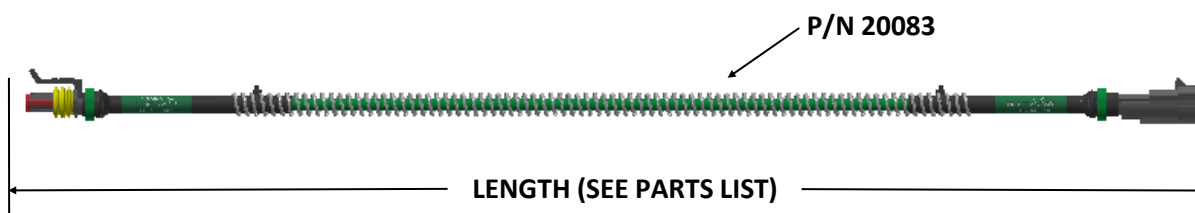
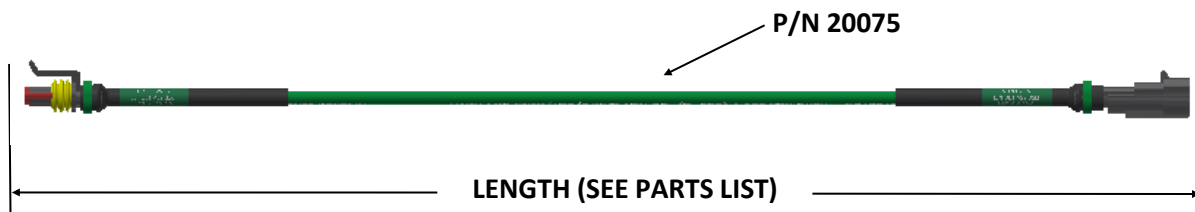

Part No.	Description
20075-03	Linear Heat Detector 3 Ft.
20075-05	Linear Heat Detector 5 Ft.
20075-10	Linear Heat Detector 10 Ft.
20075-16	Linear Heat Detector 16 Ft.
20075-20	Linear Heat Detector 20 Ft.
20075-25	Linear Heat Detector 25 Ft.
20083-05	Linear Heat Detector w/ Spring 5 Ft.
20083-10	Linear Heat Detector w/ Spring 10 Ft.
20083-16	Linear Heat Detector w/ Spring 16 Ft.
20083-20	Linear Heat Detector w/ Spring 20 Ft.
20083-25	Linear Heat Detector w/ Spring 25 Ft.

A linear heat detector is a normally open device that closes when subjected to heat. The device is comprised of two internal coiled spring loaded conductors. The Amerex linear heat detector is green in color and has a temperature set-point of 356°F [180°C]. The linear heat detector can be routed throughout the hazard areas over likely ignition and fuel sources. When the ambient temperature rises above 356°F [180°C], the insulation surrounding in the internal coiled conductors melts away allowing the two conductors to come in contact with each other which actuates the fire alarm signal. The protective spring covered linear detector is recommend-ed for all off road use and other severe service applications to protect against abrasion and impact.





SAFE IR OPTICAL FLAME SENSOR

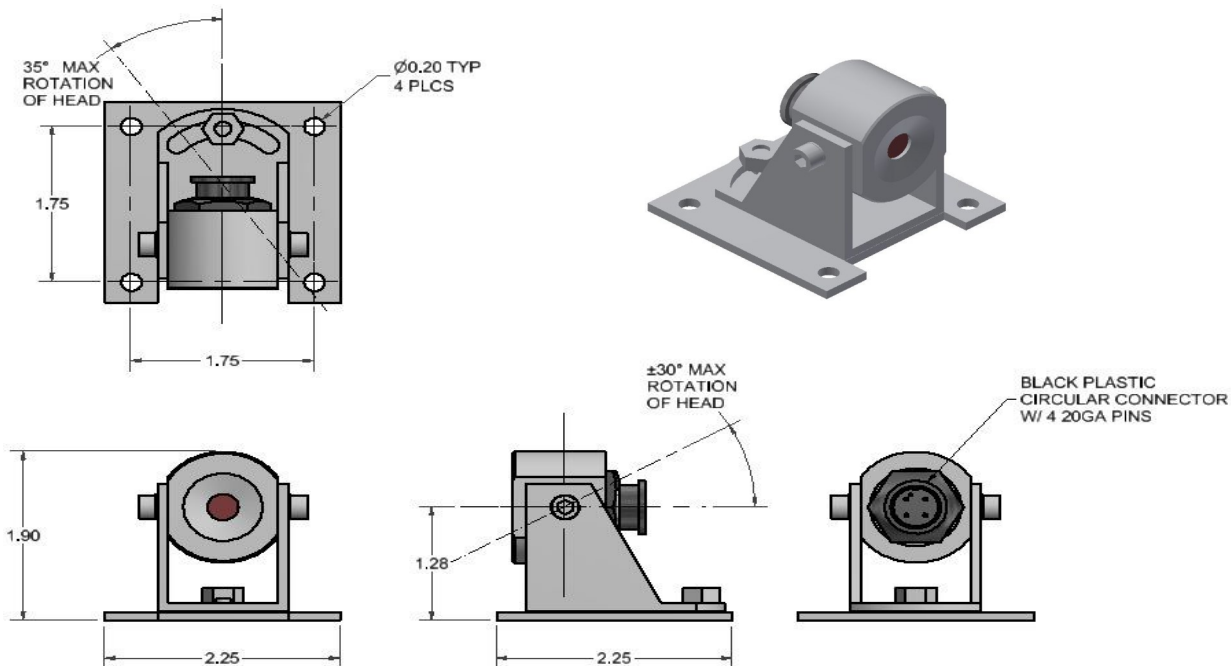

P/N: 15799

The Safe IR optical flame sensor is designed specifically for rapid response flame detection in under-hood, vehicle applications. The sensor operates by detecting CO₂ emissions from a hydrocarbon fire. The infrared wavelength of CO₂ and the specific characteristics of a hydrocarbon fire allow the safe IR sensor to discriminate against background noise and other hot bodies common in vehicle engine compartments. The detection range of the safe-IR system is a ratio function of the sensor field of view versus the emitted energy created by a fire condition. That is, as the field of view is increased (i.e. distance from the lens increases) the size of the fire to be detected must also increase in order to maintain constant detection sensitivity. The characteristics of a fire condition are differentiated from other signals commonly found in an engine compartment. The sensor housing is water and vibration resistant. The low profile/flexible design allows for ease of design application and installation. The safe-IR sensor is designed with a wide field of view of (approximately 90 degree cone).





METHANE GAS SENSOR

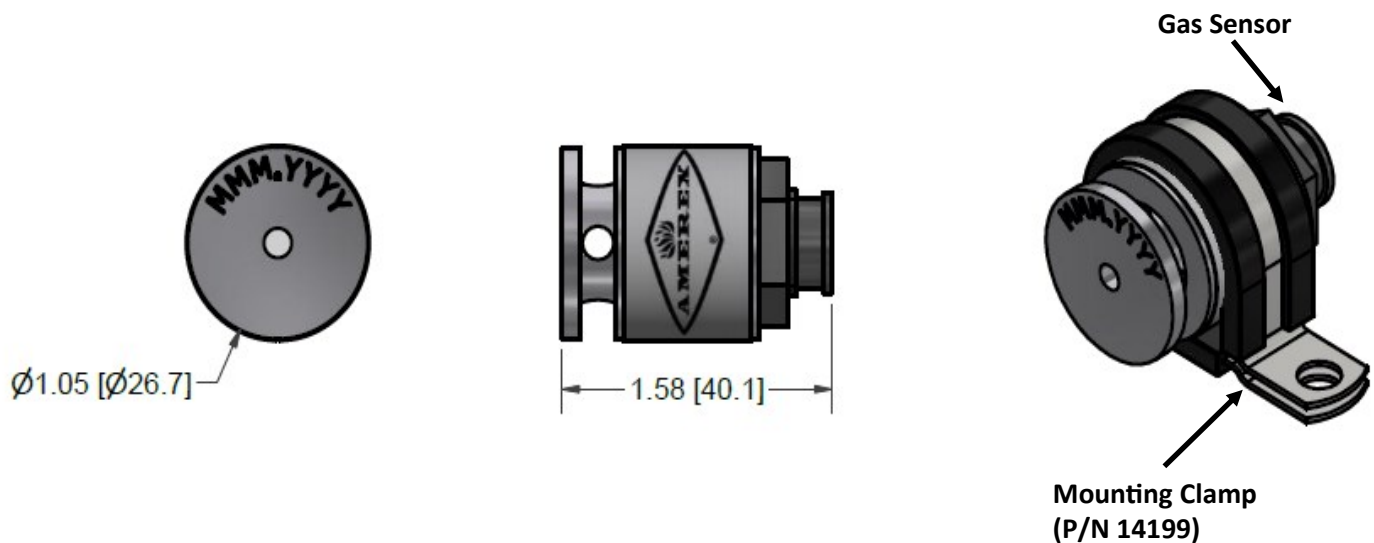

P/N: 14198

The methane gas sensor is designed specifically for vehicle use. Methane (CH₄) is the primary component in CNG and LNG fuels. Methane gas is lighter than air and can be flammable in concentrations ranging from 5% to 15% volume in atmosphere. The methane gas sensor is designed to provide detection of methane gas in concentrations below the Lower Flammability Limit (LFL) of methane, more specifically 20% of the LFL for trace alarm and 50% of the LFL for significant alarm. Methane gas sensors are anodized silver.

Sensor has a five (5) year shelf life while sealed in shipping bag and a maximum four (4) year service life.





SELECT METHANE GAS SENSOR

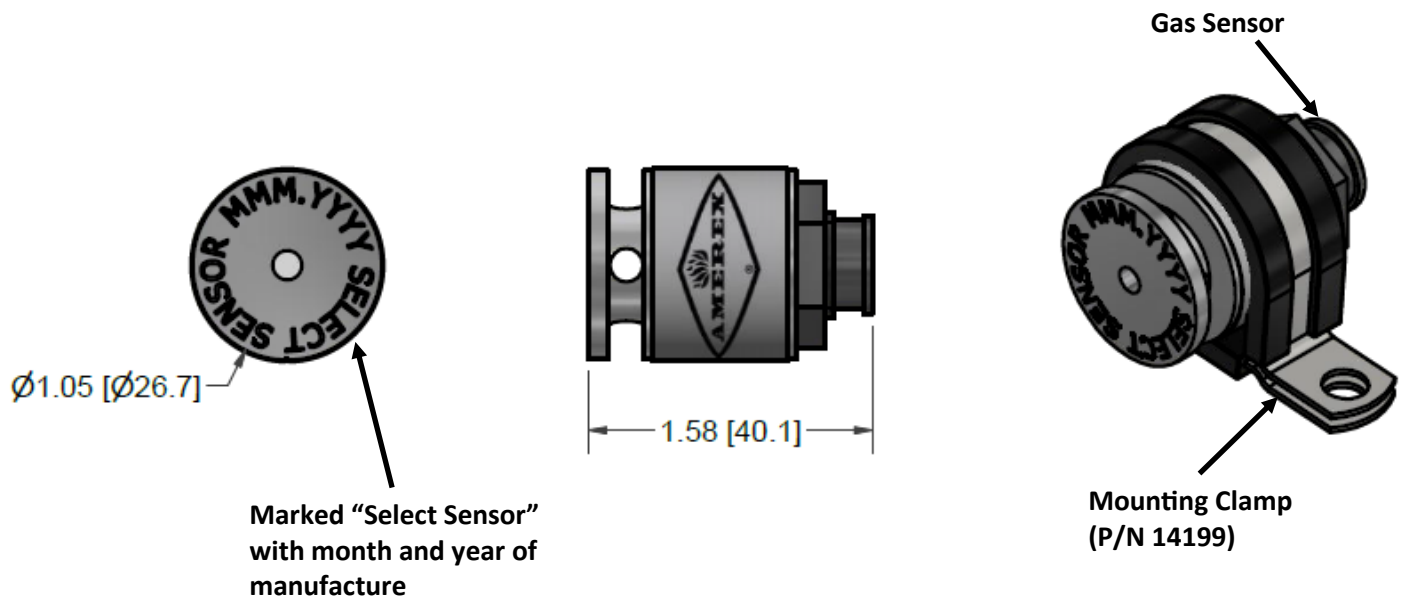

P/N: 17357

The select methane gas sensor is very similar to the standard methane gas sensor, except with a tighter tolerance range for indication of “Trace” and “Significant” gas concentrations. The select methane gas sensor is housed in an aluminum body that is anodized silver with a permanent mark “Select Sensor” and the Month-Year of manufacture.

Sensor has a five (5) year shelf life while sealed in shipping bag and a maximum four (4) year service life.





HYDROGEN GAS SENSOR

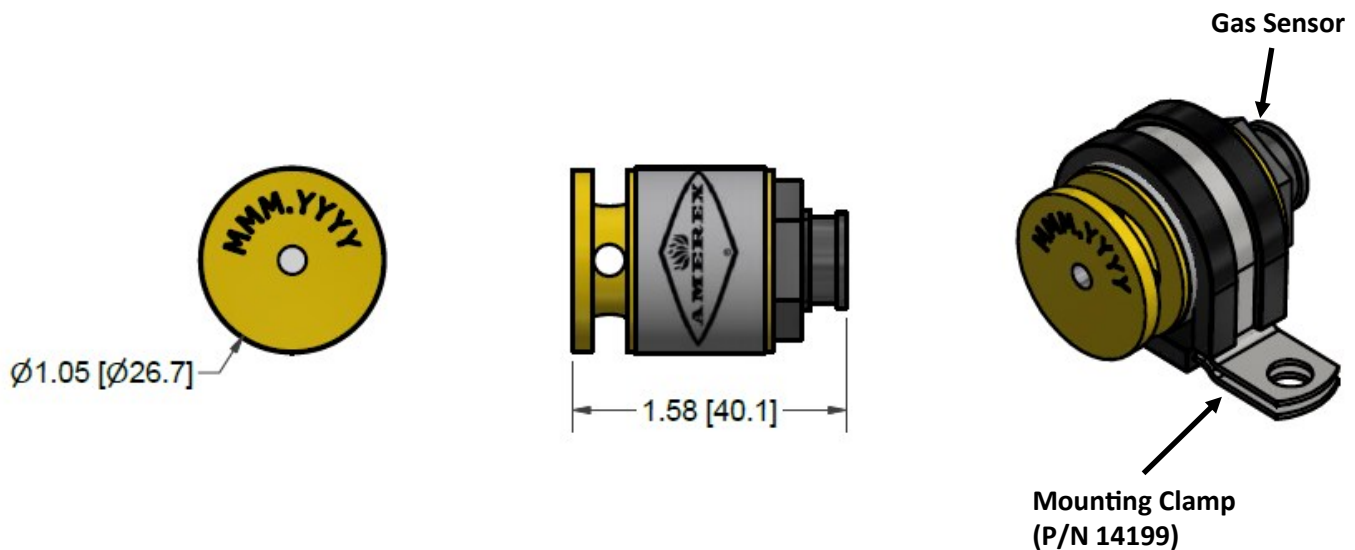

P/N: 16352

The hydrogen gas sensor is designed specifically for vehicle use. Hydrogen gas is lighter than air and can be flammable in concentrations ranging from 4% to 75% volume in atmosphere. The hydrogen gas sensor is designed to provide detection of hydrogen gas in concentrations below the lower flammability limit (LFL) of hydrogen, more specifically 20% of the LFL for trace alarm and 50% of the LFL for significant alarm. The hydrogen gas sensor will detect other combustible hydrocarbon gases if present, but is factory calibrated specifically to provide early warning in the event of hydrogen gas leakage. Hydrogen gas sensors are anodized gold.

Sensor has a five (5) year shelf life while sealed in shipping bag and a maximum four (4) year service life.





CONNECTION CABLE KIT

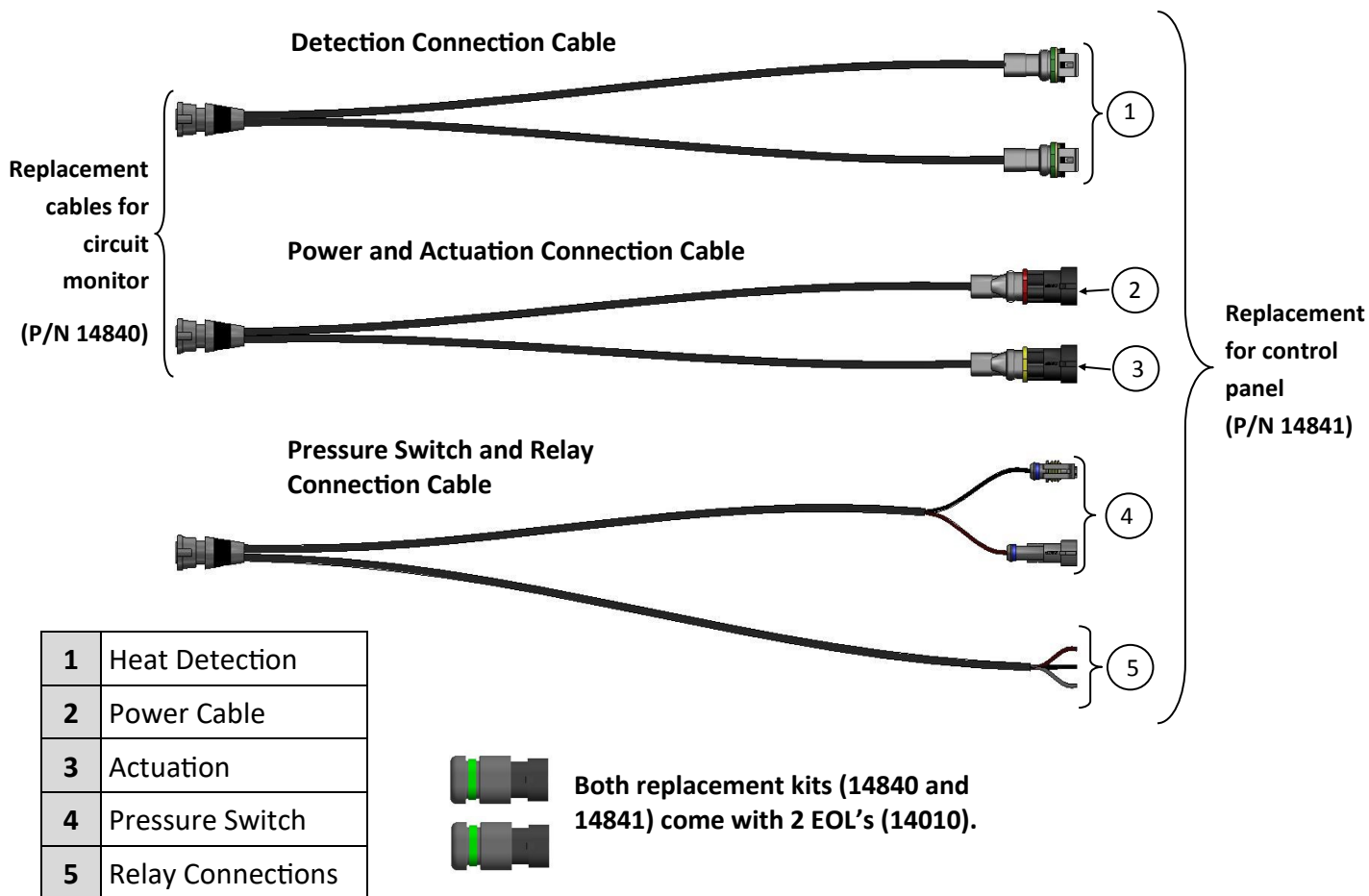

P/N: 14840/14841

The Amerex Circuit Monitor and Control Panels come complete with the required connection cables and two EOL. Replacement connection cables can be ordered as part of a larger kit (P/N 14840/14841) containing one set of connection cables along with 4 additional cables not used with the Circuit Monitor or Control Panel .





POWER CABLE

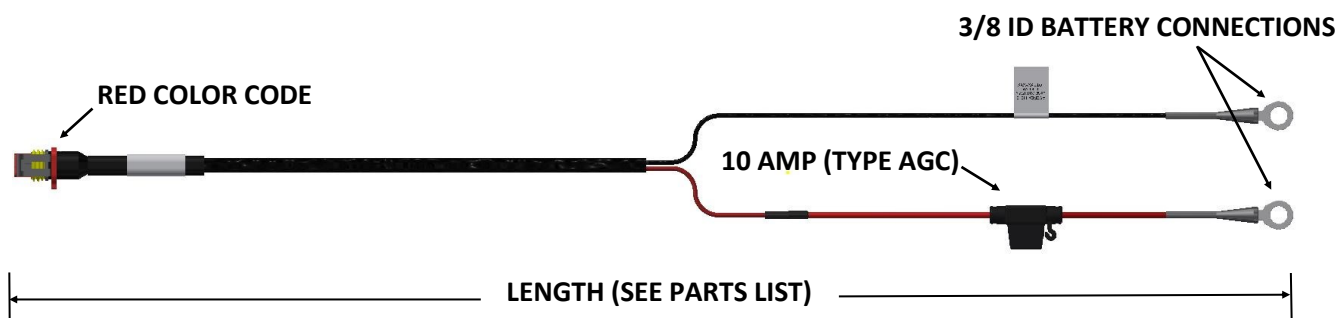

Part No.	Length
26620-10	10 Feet
26620-15	15 Feet
26620-20	20 Feet
26620-25	25 Feet
26620-30	30 Feet
26620-40	40 Feet
26620-50	50 Feet
26620-60	60 Feet
26620-75	75 Feet

The power cable is used to supply power to the Amerex circuit monitor and control panel by connecting the units to a power source. The cable is terminated with a sealed connector and ring terminals with a 10 Amp fuse located on the red (+) wire. Color coding (red) can be found on the terminated connector. Various lengths of this cable are available and shown in the parts list.





HAZARD WIRE LEAD ASSEMBLY

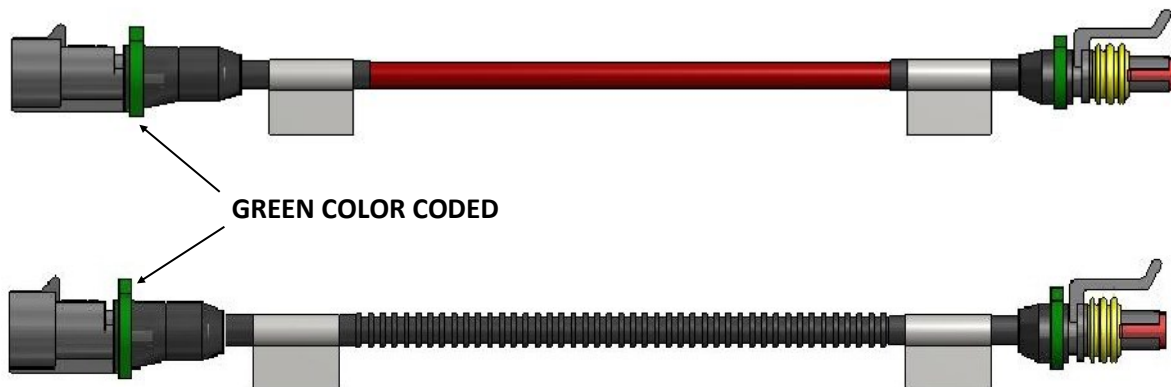

Part No.	Description
13981	Hazard Wire Lead 3 Ft.
13982	Hazard Wire Lead 6 Ft.
13983	Hazard Wire Lead 10 Ft.
13984	Hazard Wire Lead 15 Ft.
13985	Hazard Wire Lead 20 Ft.
13986	Hazard Wire Lead 30 Ft.
13987	Hazard Wire Lead 40 Ft.
13988	Hazard Wire Lead 50 Ft.
17063	Hazard Wire Lead 60 Ft.
16457	Heavy Hazard Lead 3 Ft.
16458	Heavy Hazard Lead 6 Ft.
16459	Heavy Hazard Lead 10 Ft.
16460	Heavy Hazard Lead 15 Ft.
16461	Heavy Hazard Lead 20 Ft.

The class B hazard detection cable is identified by the single green color coded cable tie shown at each end of the cable. The class B cable is used to connect to either a linear heat detector, spot heat detector or manual actuation button with controls of the associated electronics package. The cable is available in various lengths and has a connector on each end.

An additional line of heavy-duty hazard wire class B detection Circuit assemblies come with solid abrasion resistant outer sleeve installed over the standard hazard wire and sealed over the modular pluggable connectors at each end. The cable is available in various lengths and is equipped with suitable green color coded pluggable connectors on each end.





LINEAR ACTUATOR LEAD ASSEMBLY

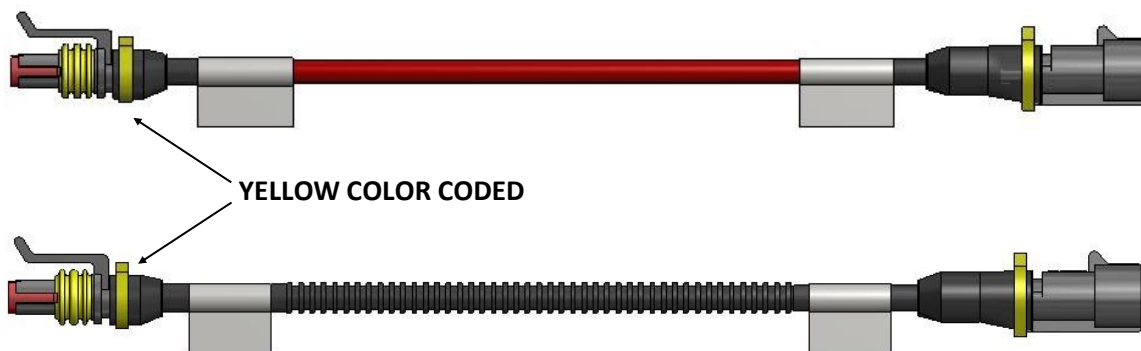

Part No.	Description
14723	Linear Actuator Lead 3 Ft.
14724	Linear Actuator Lead 6 Ft.
14123	Linear Actuator Lead 10 Ft.
14124	Linear Actuator Lead 20 Ft.
14125	Linear Actuator Lead 30 Ft.
14126	Linear Actuator Lead 40 Ft.
14127	Linear Actuator Lead 50 Ft.
16470	Heavy Actuator Lead 3 Ft.
16471	Heavy Actuator Lead 6 Ft.
16472	Heavy Actuator Lead 10 Ft.
16473	Heavy Actuator Lead 20 Ft.

The linear actuator connector lead assembly is used to connect the linear actuator to the driver panel or release module. The actuator connector lead is a two-conductor wire equipped with yellow color-coded Amerex connectors. These connectors mate with the associated connector at the control panel and the linear actuator.

An additional line of heavy-duty actuator lead wire assemblies come with a solid abrasion resistant outer sleeve installed over the standard red hazard area wire and sealed to the modular pluggable connectors at each end.

Various lengths of this cable are available and shown in the parts list.





PRESSURE SWITCH CABLE

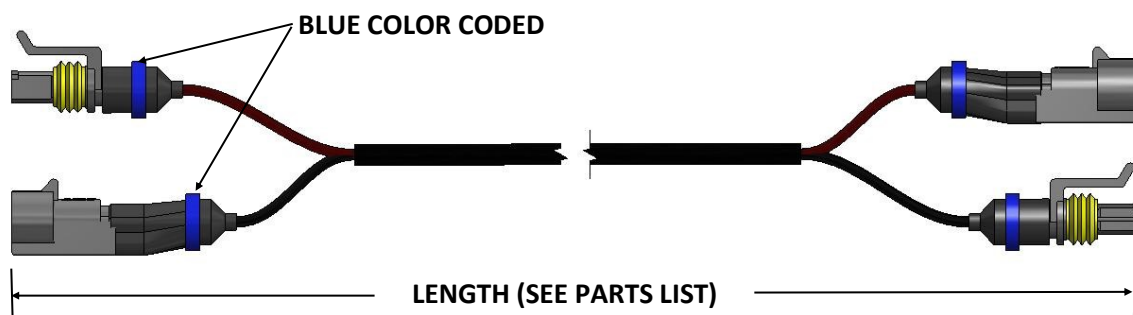

Part No.	Description
21539-10	Pressure Switch Cable 10 Ft.
21539-20	Pressure Switch Cable 20 Ft.
21539-30	Pressure Switch Cable 30 Ft.
21539-40	Pressure Switch Cable 40 Ft.
21539-50	Pressure Switch Cable 50 Ft.
21539-55	Pressure Switch Cable 55 Ft.

The pressure switch cable is used to connect the control panel and SafetyNet to a pressure switch located on an agent cylinder valve. Each is terminated with sealed connectors and color coding (blue) can be found on each connector. Various lengths of this cable are available and shown in the parts list.





PRESSURE SWITCH LEAD: SINGLE CONDUCTOR

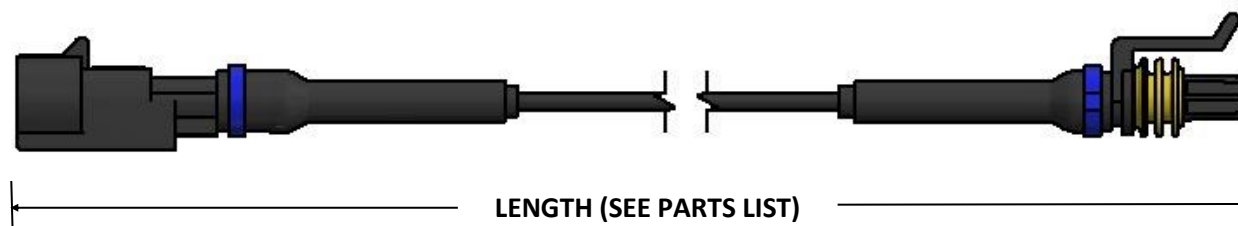

Part No.	Description
22207-03	Pressure Switch Lead, Single Conductor 3 Ft
22207-10	Pressure Switch Lead, Single Conductor 10 Ft
22207-15	Pressure Switch Lead, Single Conductor 15 Ft
22207-20	Pressure Switch Lead, Single Conductor 20 Ft

The pressure switch cable is used to connect the control panel and SafetyNet to a pressure switch located on an agent cylinder valve. Each is terminated with sealed connectors and color coding (blue) can be found on each connector. Various lengths of this cable are available and shown in the parts list.





AGENT CYLINDER PRESSURE SWITCH

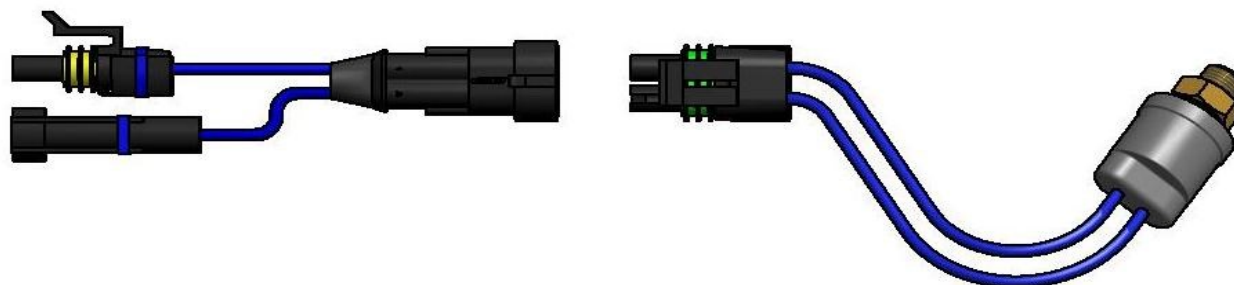

P/N: 17609-P001

The agent cylinder pressure switch is supplied with and connected directly to the agent cylinder valve. This switch is designed to monitor agent cylinder pressure. The switch is closed in a pressurized agent cylinder and opens when agent cylinder pressure drops below 270 psi indicating a discharged or leaking agent cylinder. Reference the appropriate Amerex Fire Suppression Installation, Operation and Maintenance Manual for selection of agent cylinders with pressure switches.





SAFETYNET INTERFACE MODULE

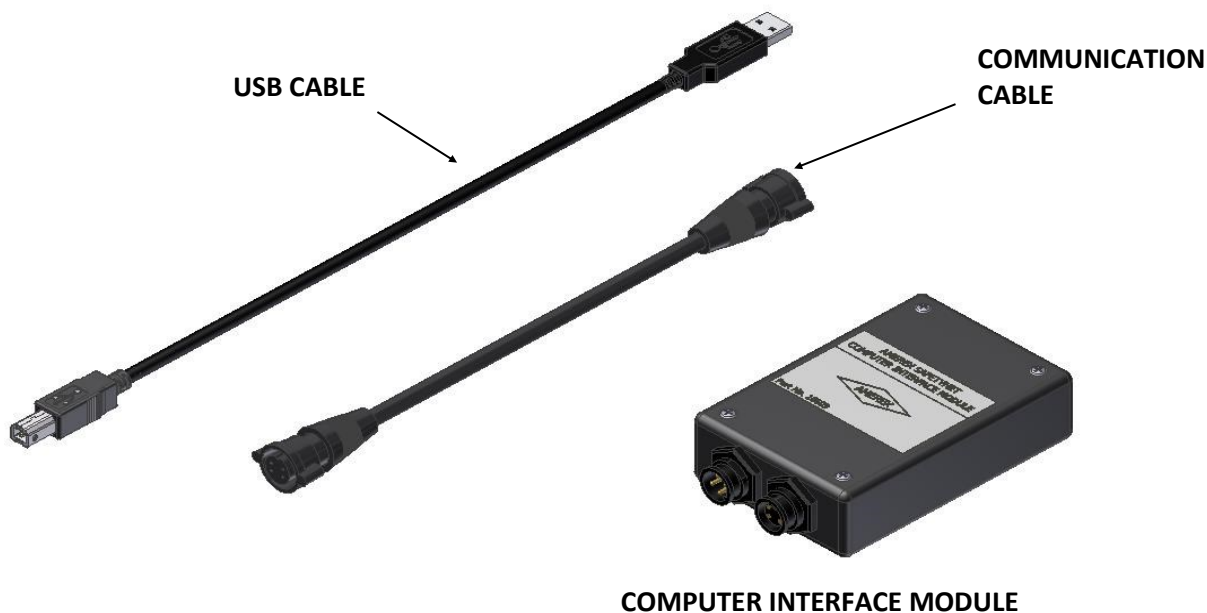

P/N: 16609

The SafetyNet interface module includes both male and female connectors and is supplied with a communication cable (P/N 14925) which can be installed to fit either male or female SafetyNet output ports. Each SafetyNet installation will end up with two unused communication ports – either male or female - at the first and last modules in the system. The interface module is used to access SafetyNet system data logs, special setups and programming if desired. It is not required for standard self-configured system operations.





ALARM TEST MODULE

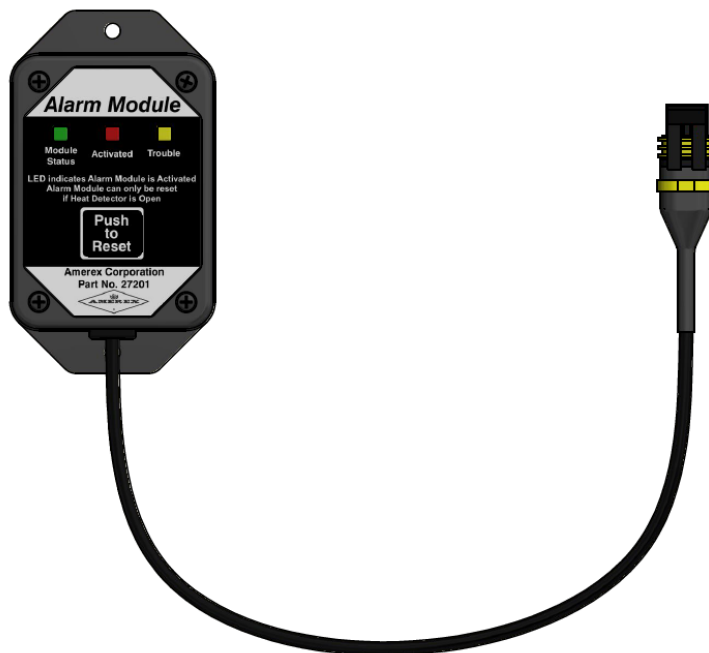

P/N: 27201

The Alarm Module provides a means of functionally testing actuation circuits. This device is installed at the end of the actuation circuit, in place of a Linear Actuator, when performing function testing or required maintenance. This device contains an LED indicator which illuminates when the actuation circuit is activated and can be manually reset afterwards by pressing the 'Push to Reset' button. Color coding (yellow) can be found on the cable end.

The Alarm Module takes a AA lithium battery. If the Alarm Module yellow Fault LED is on, this indicates a low voltage, replace battery.

This is a direct replacement to the previous module, P/N 21447





COMMUNICATION CABLE

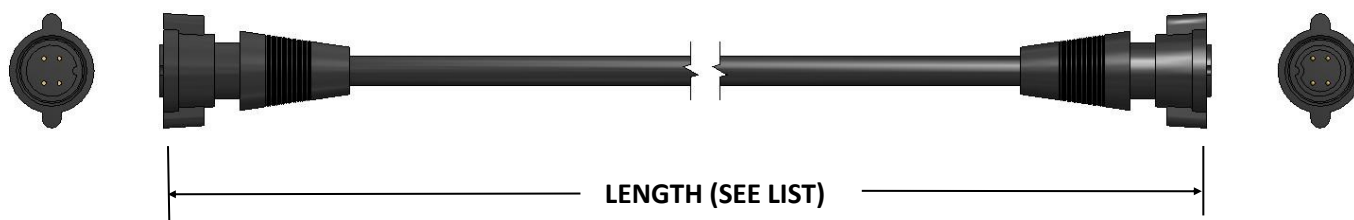

Part No.	Length
26619-18IN	18 Inch
26619-03	3 Feet
26619-10	10 Feet
26619-15	15 Feet
26619-20	20 Feet
26619-25	25 Feet
26619-35	35 Feet
26619-50	50 Feet
26619-65	65 Feet
26619-85	85 Feet
26619-100	100 Feet

The standard AMGaDS four-wire sensor cable is used for connection of SafetyNet operator display panel to other SafetyNet modules and for connection of additional modules to each other. They are also used to connect the safe IR optical flame detector, and also Amerex gas sensors to various SafetyNet modules.





AMGaDS IV CONTROL PANEL

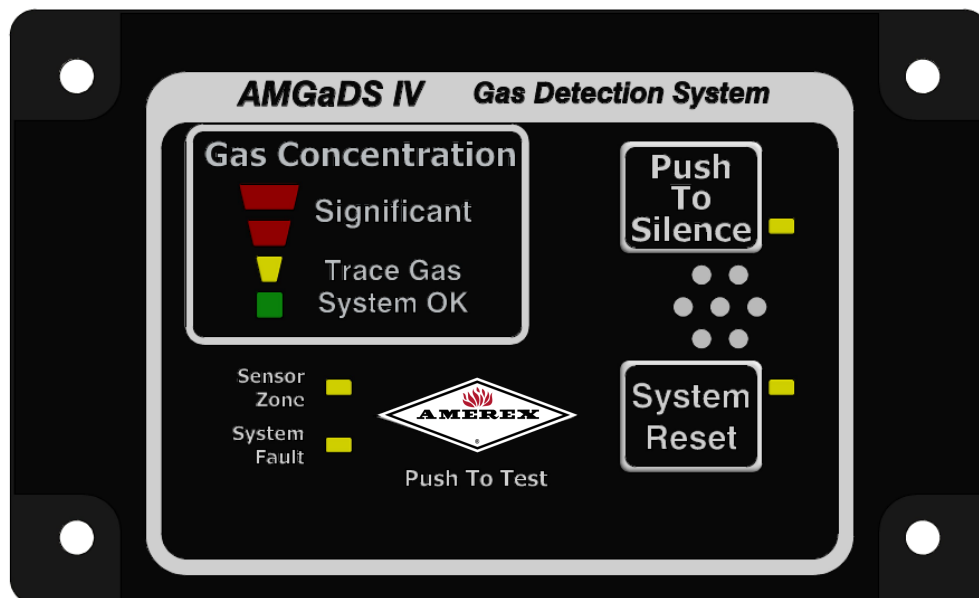

P/N: 22529

The Control Panel indicates system status and gas level alarms to the vehicle operator. It is designed to be flush mounted with all wiring exiting the back of the panel via a single connector with connections for Power, up to 4 Gas Sensors, and auxiliary Input/Outputs. Control Panel front face LED indicators are System Normal, Gas Concentration Alarm, Sensor Zone, System Fault, Alarm Silence and Output Status. Also provided are buttons for Alarm Silence, System Reset and System Test. An audible alarm is also located on the front face.





AMGaDS IV CONTROL PANEL DATA

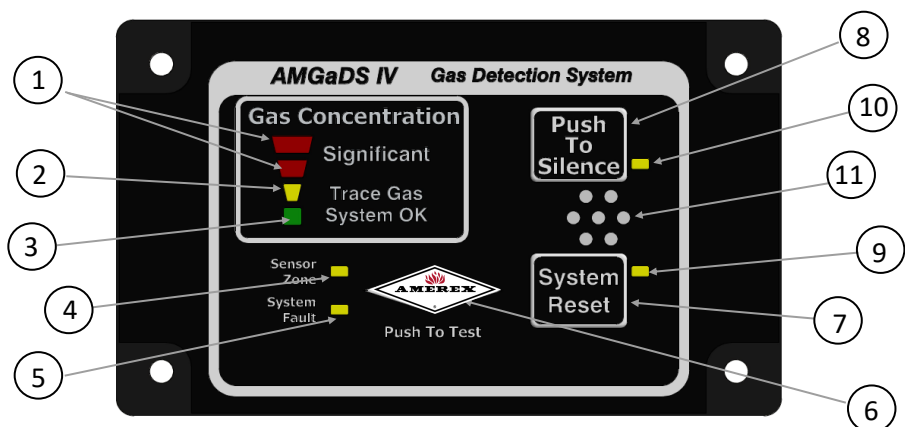

Control Panel Features	
1	Significant Gas LED
2	Trace Gas LED
3	System Normal LED
4	Sensor Zone LED
5	System Fault LED
6	Push To Test Button
7	System Reset Button
8	Push To Silence Button
9	Output Status LED
10	Push To Silence LED
11	Audible Alarm

P/N: 22529

All dimensions are in inches [mm]. The enclosure has four mounting holes for #8 mounting screws.

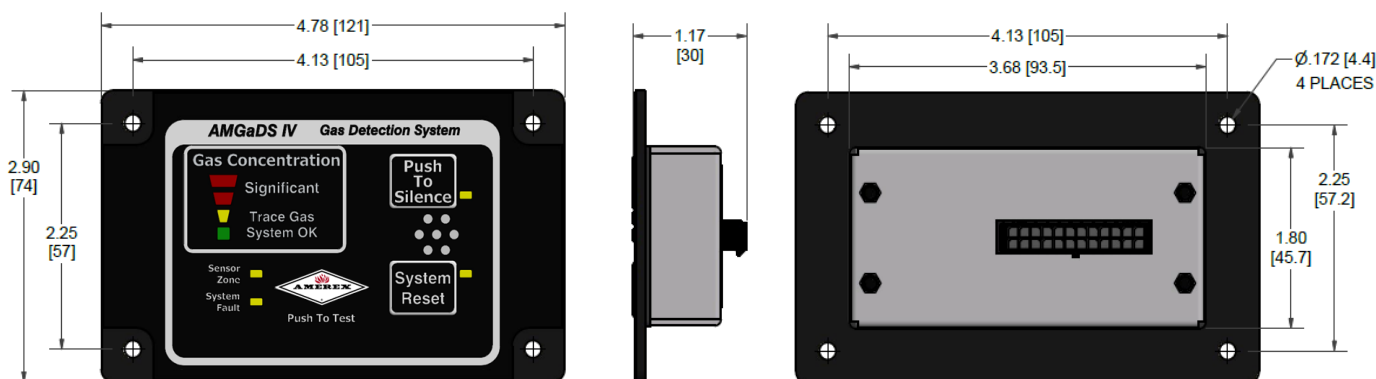

Quality is Behind the Diamond
 Copyright © Amerex® Corporation

AMEREX® CORPORATION
 P.O. Box 81
 7595 Gadsden Highway
 Trussville, AL 35173
 +1 (205) 655-3271
 www.amerex-fire.com

tech.services@Amerex-fire.com
 customer.service@Amerex-fire.com
 sales@Amerex-fire.com

Rev Aug 2020



METHANE GAS SENSOR

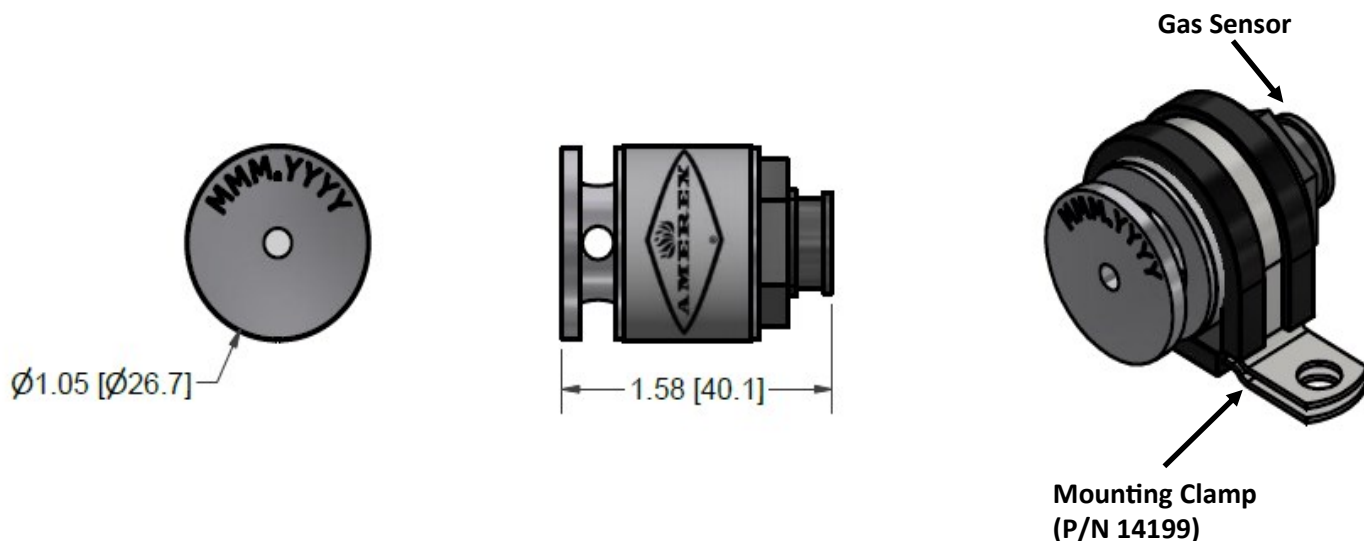

P/N: 14198

The methane gas sensor is designed specifically for vehicle use. Methane (CH₄) is the primary component in CNG and LNG fuels. Methane gas is lighter than air and can be flammable in concentrations ranging from 5% to 15% volume in atmosphere. The methane gas sensor is designed to provide detection of methane gas in concentrations below the Lower Flammability Limit (LFL) of methane, more specifically 20% of the LFL for trace alarm and 50% of the LFL for significant alarm. Methane gas sensors are anodized silver.

Sensor has a five (5) year shelf life while sealed in shipping bag and a maximum four (4) year service life.





SELECT METHANE GAS SENSOR

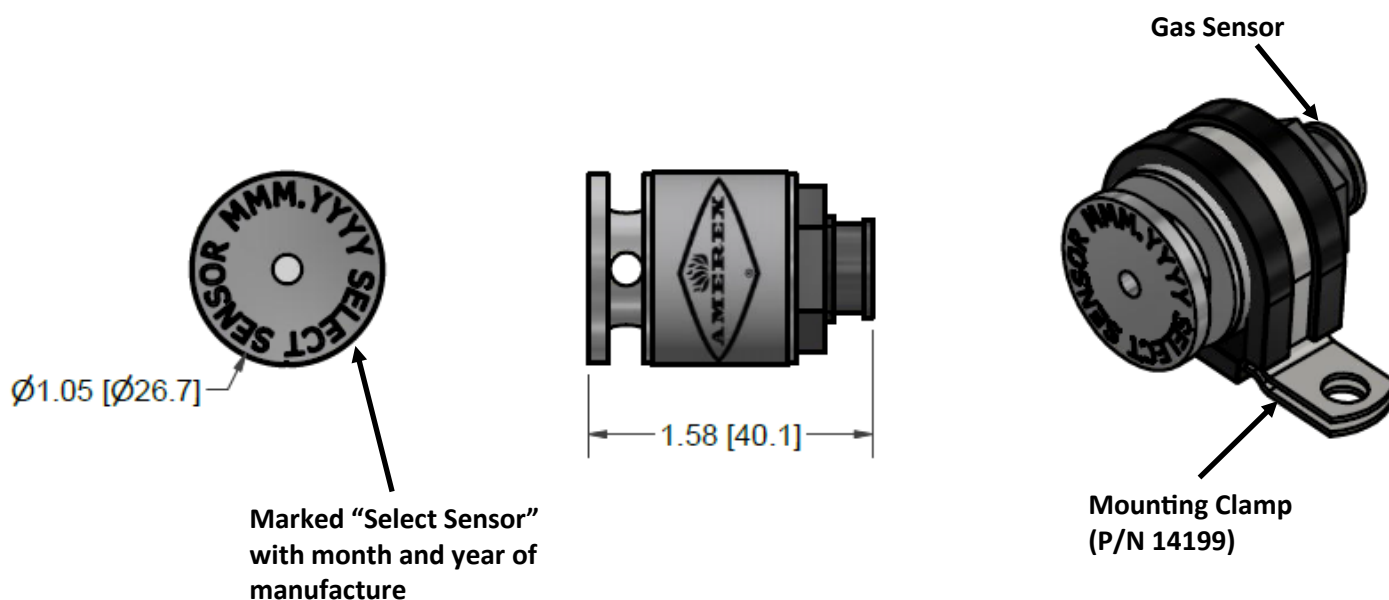

P/N: 17357

The select methane gas sensor is very similar to the standard methane gas sensor, except with a tighter tolerance range for indication of “Trace” and “Significant” gas concentrations. The select methane gas sensor is housed in an aluminum body that is anodized silver with a permanent mark “Select Sensor” and the Month-Year of manufacture.

Sensor has a five (5) year shelf life while sealed in shipping bag and a maximum four (4) year service life.





HYDROGEN GAS SENSOR

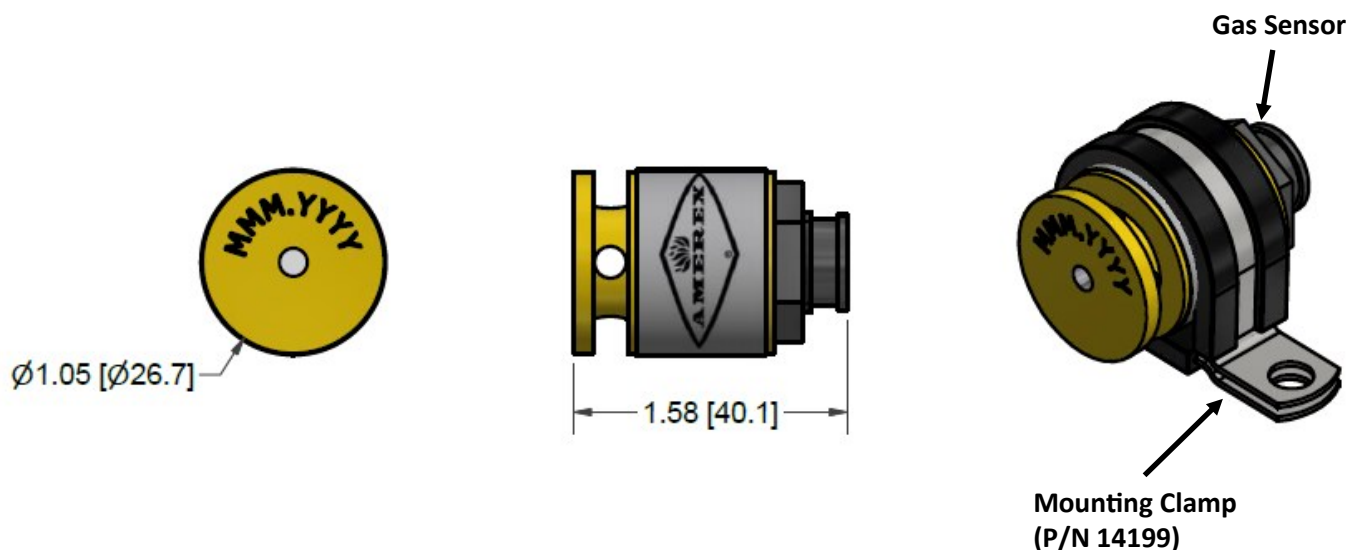

P/N: 16352

The hydrogen gas sensor is designed specifically for vehicle use. Hydrogen gas is lighter than air and can be flammable in concentrations ranging from 4% to 75% volume in atmosphere. The hydrogen gas sensor is designed to provide detection of hydrogen gas in concentrations below the lower flammability limit (LFL) of hydrogen, more specifically 20% of the LFL for trace alarm and 50% of the LFL for significant alarm. The hydrogen gas sensor will detect other combustible hydrocarbon gases if present, but is factory calibrated specifically to provide early warning in the event of hydrogen gas leakage. Hydrogen gas sensors are anodized gold.

Sensor has a five (5) year shelf life while sealed in shipping bag and a maximum four (4) year service life.





WIRING HARNESS: TWO GAS SENSORS

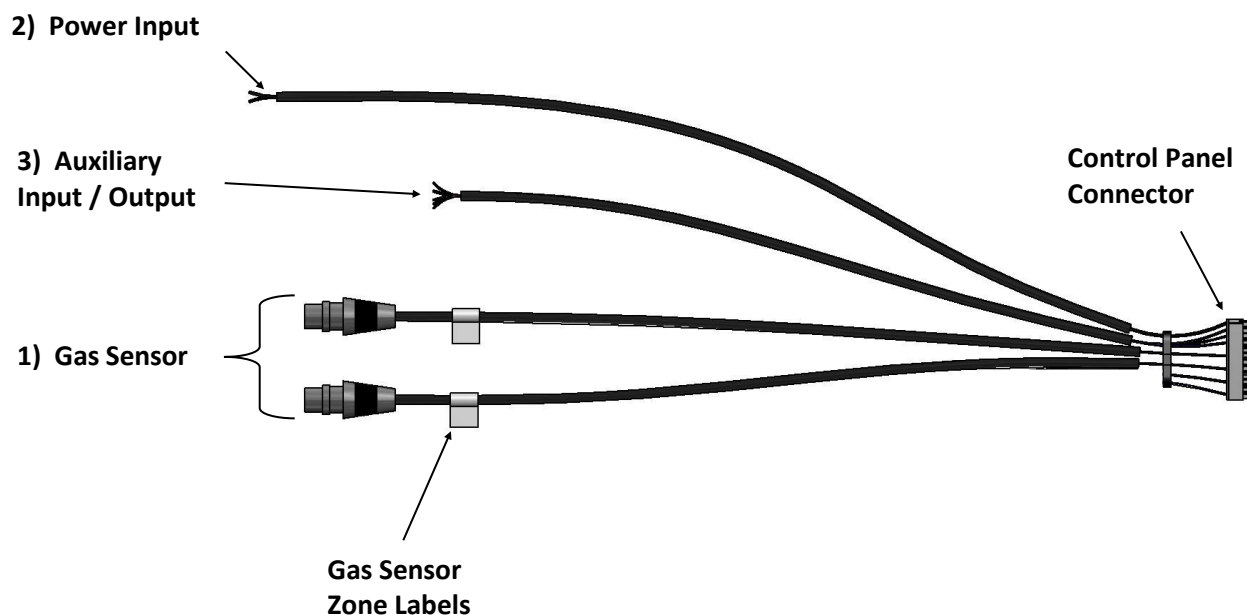

P/N: 22528-2

The AMGADS IV Wiring Harness (included with Control Panel) is used to connect the Control Panel to the Gas Sensor Cables, input power, and any auxiliary output devices. One end features a single female connector which mates with the Control Panel, and the other end features (2) Gas Sensor leads with locking connectors, a power input lead, and an auxiliary input/output lead. Gas Sensor leads are labeled according to their associated zone. The power input lead (2 wire) and auxiliary input/output lead (6 wire) are provided blunt cut and un-terminated for a variety of connection options. Wiring connections for these leads are provided by the system installer for the specific purpose intended.





WIRING HARNESS: FOUR GAS SENSORS

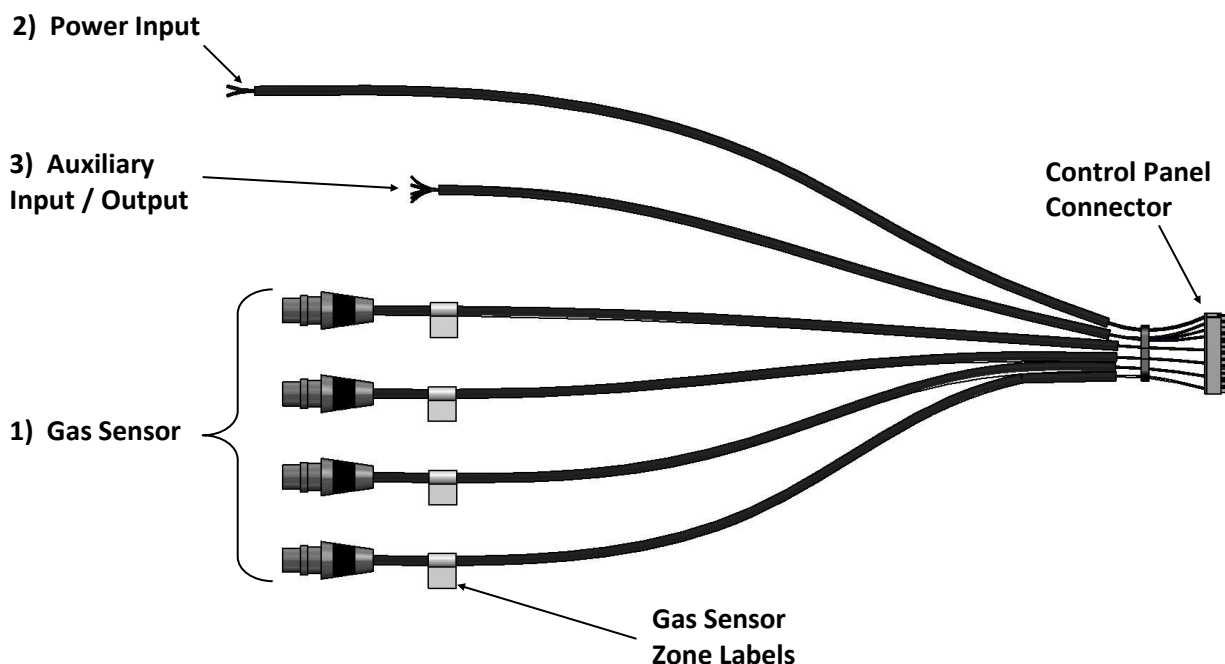

P/N: 22528-4

The AMGADS IV Wiring Harness (included with Control Panel) is used to connect the Control Panel to the Gas Sensor Cables, input power, and any auxiliary output devices. One end features a single female connector which mates with the Control Panel, and the other end features (4) Gas Sensor leads with locking connectors, a power input lead, and an auxiliary input/output lead. Gas Sensor leads are labeled according to their associated zone. The power input lead (2 wire) and auxiliary input/output lead (6 wire) are provided blunt cut and un-terminated for a variety of connection options. Wiring connections for these leads are provided by the system installer for the specific purpose intended.





COMMUNICATION CABLE

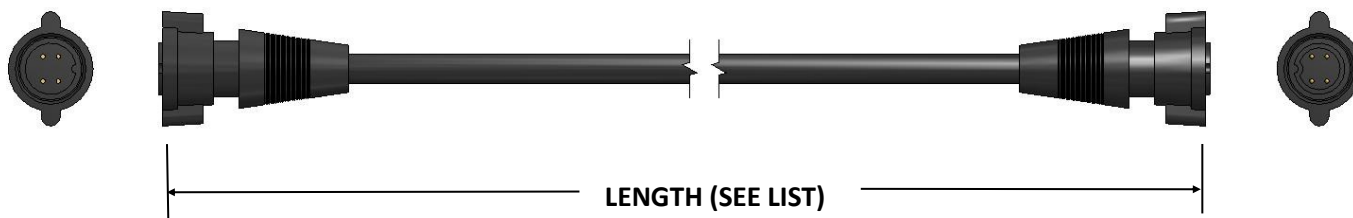

Part No.	Length
26619-18IN	18 Inch
26619-03	3 Feet
26619-10	10 Feet
26619-15	15 Feet
26619-20	20 Feet
26619-25	25 Feet
26619-35	35 Feet
26619-50	50 Feet
26619-65	65 Feet
26619-85	85 Feet
26619-100	100 Feet

The standard AMGaDS four-wire sensor cable is used for connection of SafetyNet operator display panel to other SafetyNet modules and for connection of additional modules to each other. They are also used to connect the safe IR optical flame detector, and also Amerex gas sensors to various SafetyNet modules.





SMVS DISPLAY PANEL



P/N: 17316

The SMVS Display Panel is mounted within view and reach of the operator, and in conjunction with the SMVS Control Panel, provides electrical supervision of the Power, Detection, and Releasing circuit. It features visual LED system status indicators, a silenceable audible alarm, two heat detection zones, integral manual release switch, and adjustable time delay for the relay circuit. The relay circuit includes both closed and open contacts which transfer at the end of the time delay period and is adjustable from 0-15 seconds. The relay may be used for vehicle shutdown, auxiliary alarm, or fuel pump shutoff. The Test Button verifies LED, audible and relay functions. Pressing the Test button illuminates all LED's, sounds the audible alarm and begins the relay timer countdown. In the event of a Fire condition, the audible alarm will sound, the red Fire LED will illuminate, and the discharge and relay timers begin countdown. A Discharge Delay button may be pushed to delay the relay function. The system can also be manually activated through the integral manual switch.





SMVS DISPLAY PANEL DATA

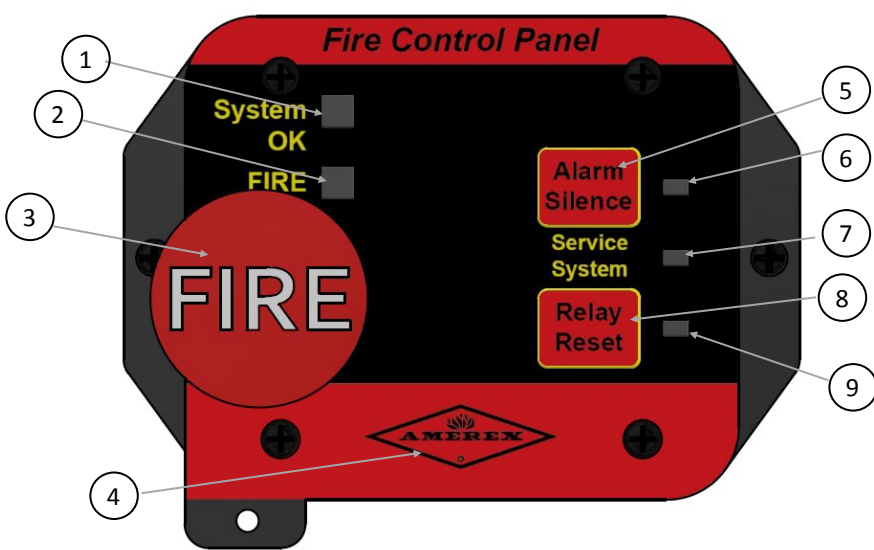

Control Panel Features	
1	Power LED
2	Fire LED
3	Fire Manual Release
4	Push to Test Button
5	Alarm Silence Button
6	Alarm Silence LED
7	Service System LED
8	Relay Reset Button
9	Relay Reset LED

P/N: 17316

All dimensions are in inches [mm].

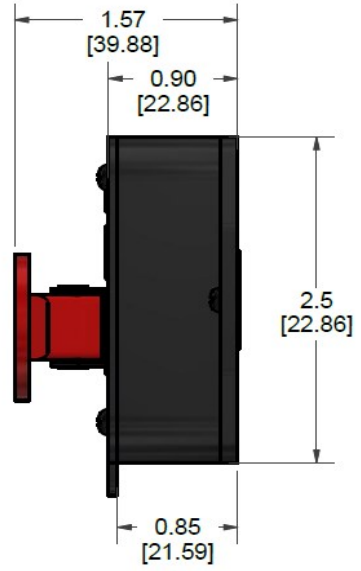
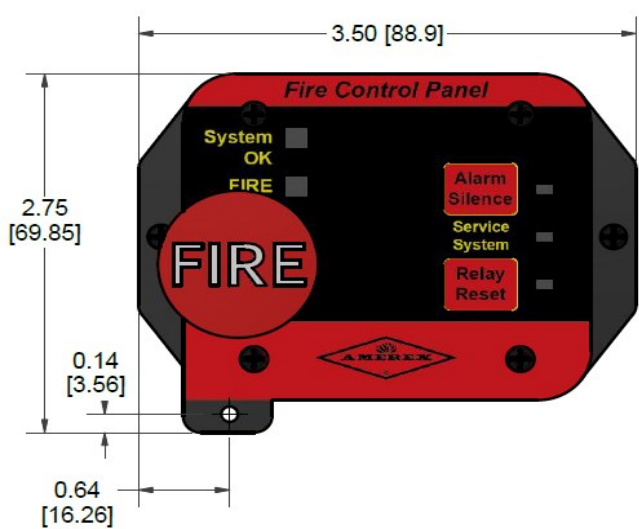

Quality is Behind the Diamond
 Copyright © Amerex® Corporation

AMEREX® CORPORATION
 P.O. Box 81
 7595 Gadsden Highway
 Trussville, AL 35173
 +1 (205) 655-3271
 www.amerex-fire.com

tech.services@Amerex-fire.com
 customer.service@Amerex-fire.com
 sales@Amerex-fire.com

Rev Aug 2020



SMVS CONTROL PANEL



P/N: 17317

The SMVS Control panel is the main connection point for all the system wiring and communicates the information to the SMVS Display Panel for the operator to view system status. The control panel is mounted next to the SMVS agent cylinder. It ships with a standard 9V alkaline battery that provides one hour of battery backup when main vehicle power is removed. The 9V alkaline battery is replaced yearly or more frequently as needed.





SMVS HEAT SENSOR

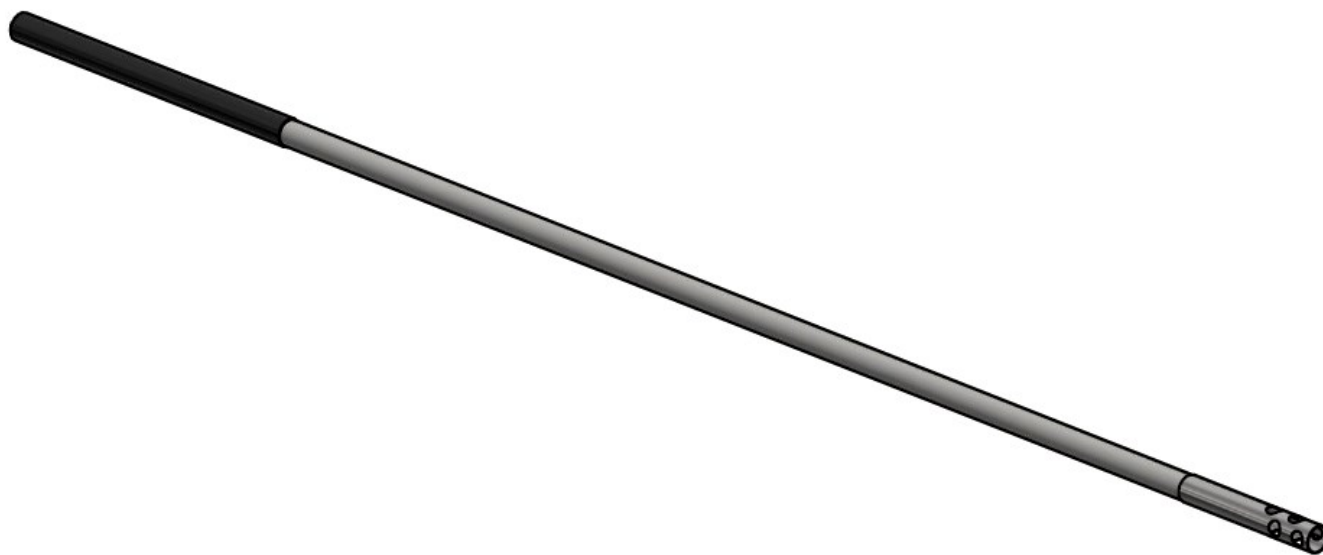

P/N: 17318

The SMVS system has two heat detection zones and utilizes two thermocouple style heat detectors rated for a 350F max temperature set point. They are installed over the engine and monitor the compartment for high heat due to a fire condition. The sensor works by the internal contacts closing due to a high heat event, shorting together, and putting the panel into alarm and activating the release circuit. Each sensor lead cable is eight feet long and plugs into the SMVS Control Panel.





ALARM TEST MODULE

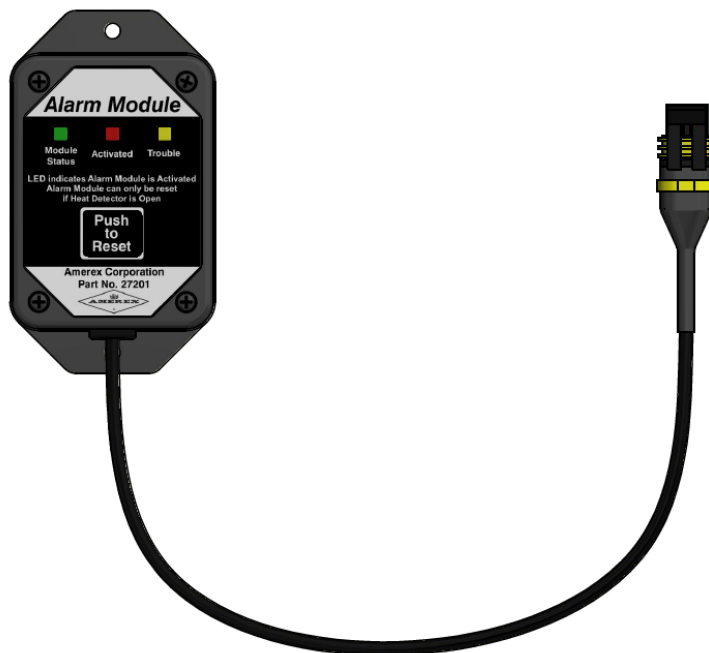

P/N: 27201

The Alarm Module provides a means of functionally testing actuation circuits. This device is installed at the end of the actuation circuit, in place of a Linear Actuator, when performing function testing or required maintenance. This device contains an LED indicator which illuminates when the actuation circuit is activated and can be manually reset afterwards by pressing the 'Push to Reset' button. Color coding (yellow) can be found on the cable end.

The Alarm Module takes a AA lithium battery. If the Alarm Module yellow Fault LED is on, this indicates a low voltage, replace battery.

This is a direct replacement to the previous module, P/N 21447





COMMUNICATION CABLE DRIVER / DISPLAY

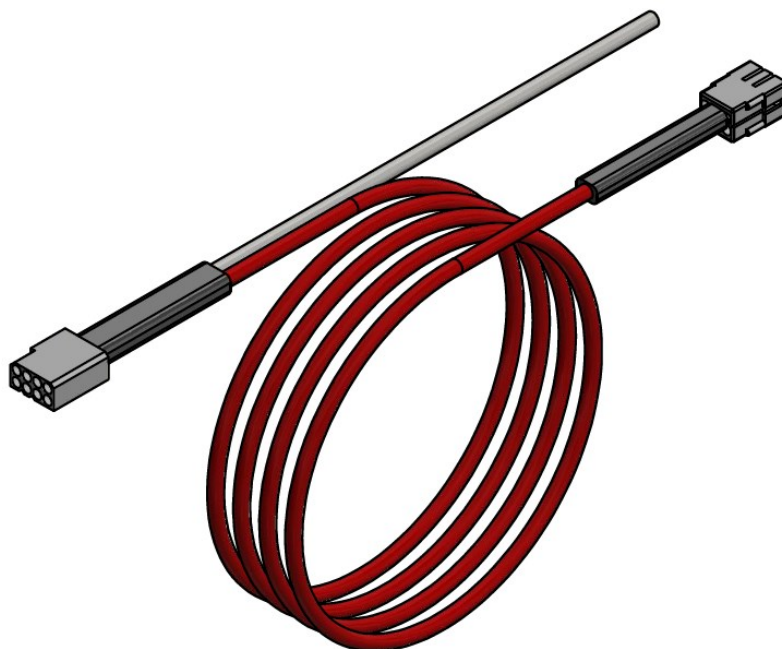

P/N: 17525

This cable connects the SMVS Control Panel to the SMVS Display Panel and provides power and communication between the two panels. The display cable is 12' long.





POWER LEAD CONNECTOR

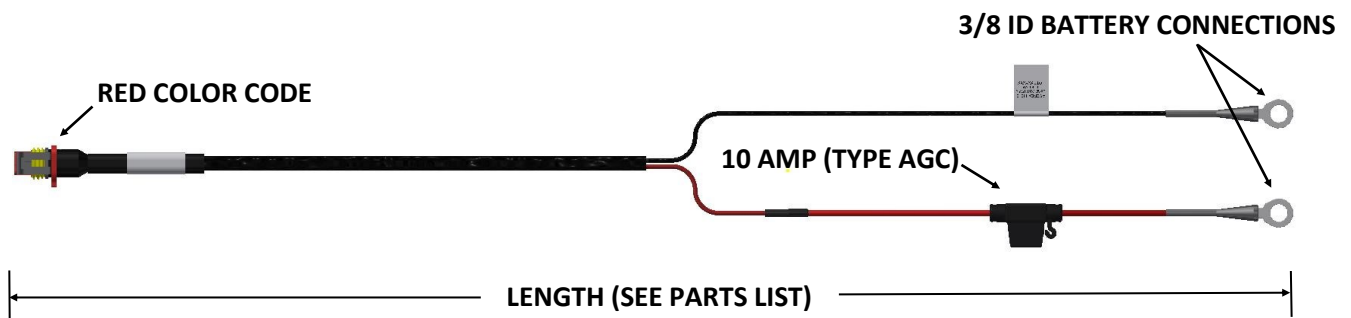

P/N: 26620-15

Standard power lead cable used across all the Amerex control panels. Connects vehicle power battery to the SMVS Control Panel. The cable is terminated with a sealed connector and ring terminals with a 10 Amp fuse located on the red (+) wire. Color coding (red) can be found on the terminated connector.





SMVS AGENT CYLINDER



SMVS 13 ABC	U.S.	METRIC
Height	17.91 in	45.5 cm
Diameter	6.97 in	17.7 cm
Capacity	13 lbs.	5.90 kg

P/N: 17276

The Replacement Agent Cylinder is shipped fully charged from the factory. Each Agent Cylinder includes a brass discharge valve with a pressure gauge. The Agent Cylinder is pressurized with nitrogen gas to a pressure of 240 psi (1654 kPa) at 70°F (21°C). The operating temperature range of the Agent Cylinders is -40°F to 150°F (-40°C to 66°C).





SMVS CYLINDER BRACKET

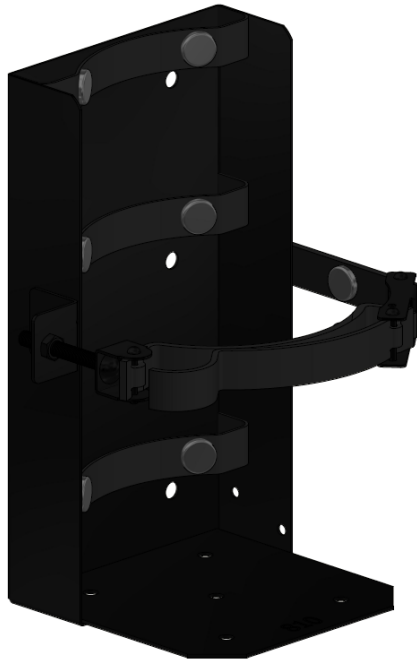

P/N: 17470

The bracket is a heavy-duty box type bracket painted black and used to mount the SMVS agent cylinder. It is fastened to the floor using the supplied hardware and supported with the bracket stiffener L-bracket. All dimensions are in inches [mm].

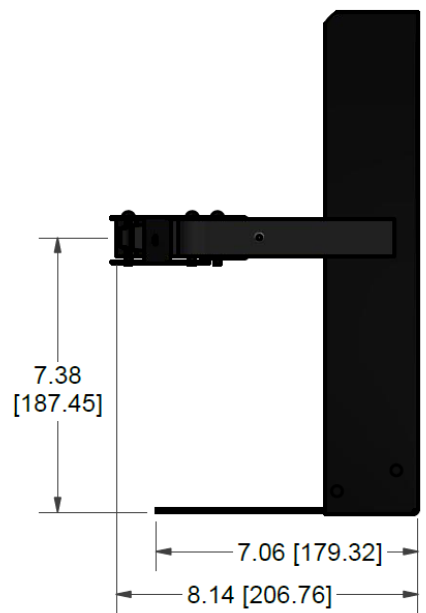
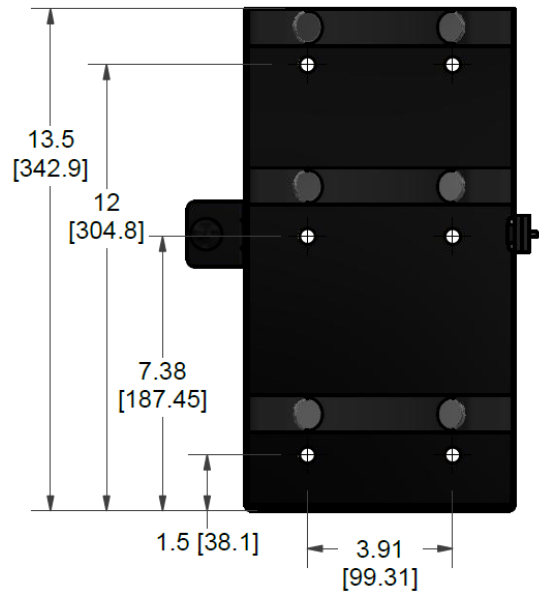



SMVS NOZZLE

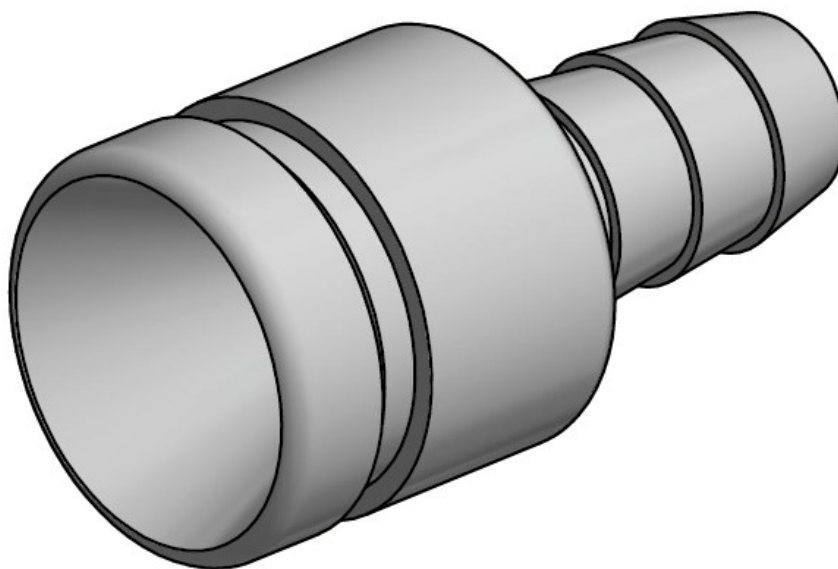

P/N: 17202

The SMVS system utilizes two nozzles that are installed in the engine compartment. They are fastened to the distribution hose connected to the SMVS agent cylinder and dispense dry chemical into the engine compartment through a cone shape discharge pattern. Each nozzle is fitted with a protective dust cap (P/N 10167-P006/P025). The nozzles are machined aluminum and have barbed ends on them to allow easy installation to the distribution hose and are secured with supplied hose clamps.





SMVS SPARE PARTS

Part No.	Description
17316	Display Panel SMVS
17317	Driver panel SMVS
17318	Sensor Heat Micro SMVS
17525	Communication Cable Driver/Display
26620-15	Conn. 15' Power Lead
17470	Bkt. Asy. SMVS
17276	Agent Cylinder SMVS
22579	Linear Actuator Asy. VS
17202	Nozzle SMVS
20178	SMVS Hose Asy 1/2" ID x 15'
10167-P006/P025	Cap Nozzle Blowoff (Bag of 6 or 25)





TEE HANDLE

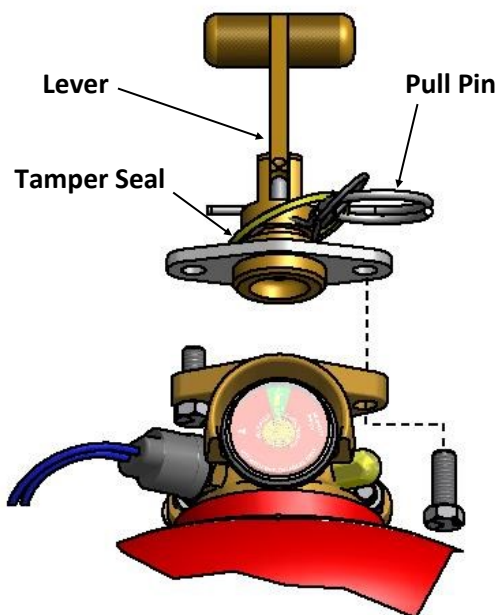

P/N: 10134

On installations where neither automatic nor remote actuation is selected, the manually activated Tee Handle can be used. This device is constructed of brass and stainless steel and bolts directly to the top of the Agent Cylinder Valve. The handle is locked in the safety position by a ring pin, which is pulled out at the time of actuation. The Tee Handle is designed to lock in place only in the FULL OPEN or FULL CLOSED position to discourage incomplete valve opening in a fire situation. The Tee Handle is also used as a service tool to open the Agent Cylinder Valve during agent cylinder recharging.





RECHARGE ADAPTER

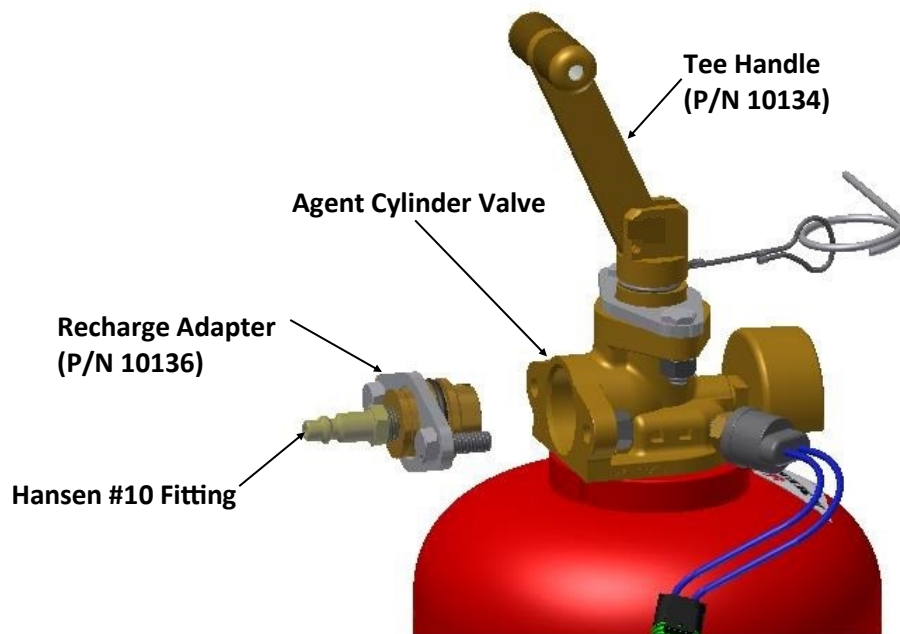

P/N: 10136

The Recharge Adapter is used to pressurize the Agent Cylinder after a discharge or maintenance and is used in conjunction with Tee Handle (P/N 10134).





HYDROTEST ADAPTERS

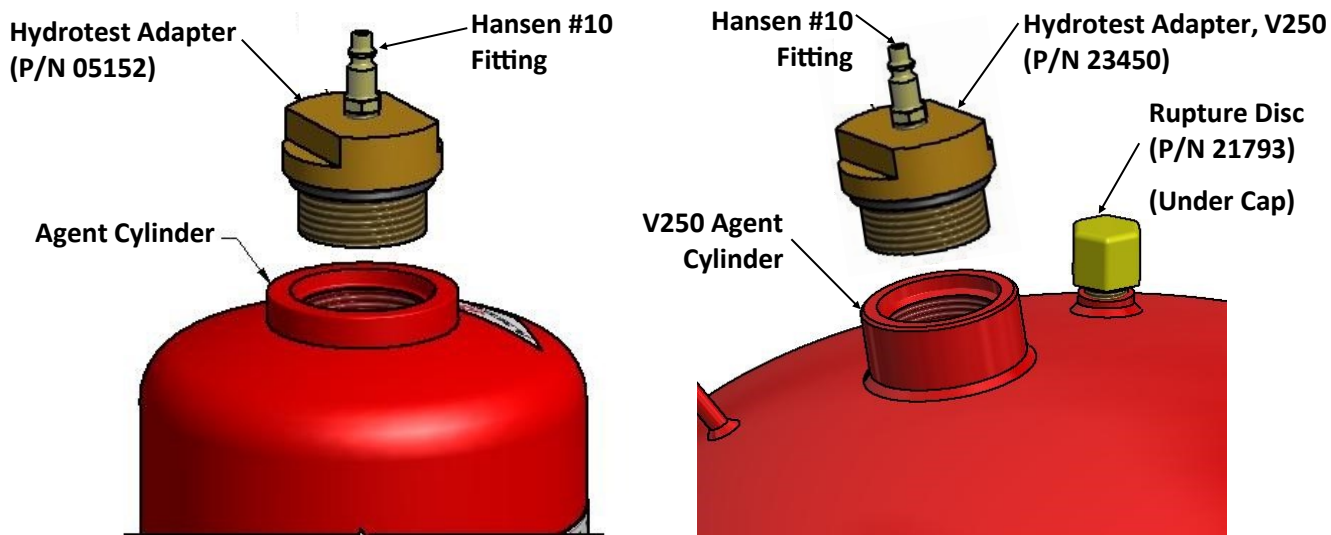

P/N: 05152 & 23450

The Hydrotest Adapter is used to pressurize the Agent Cylinder to perform DOT requirements for (12) year maintenance. V13 through VS75 Agent Cylinders use P/N 05152 and V250 Agent Cylinder use P/N 23450.





DISTRIBUTION HOSE BLOWOUT ADAPTER

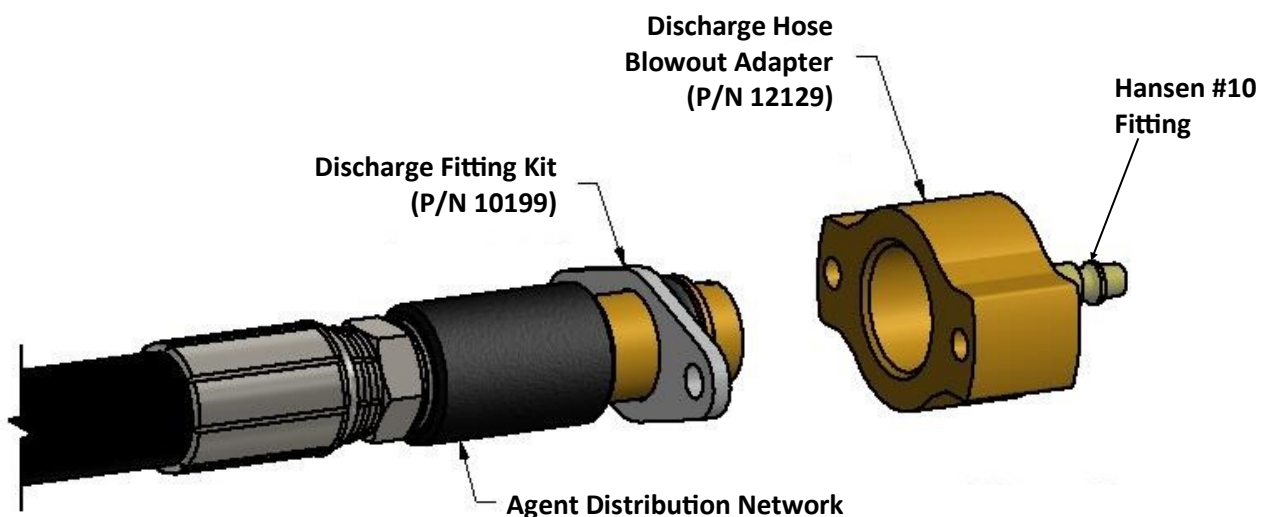

P/N: 12129

When commissioning the Amerex Modular Dry Chemical System, upon initial installation, and at each (6) six month service, the Agent Distribution Network must be purged with dry air or nitrogen at a minimum of 90 PSI (620 kPa) by using the Distribution Hose Blowout Adapter.





V250 CYLINDER BLOWOUT ADAPTER

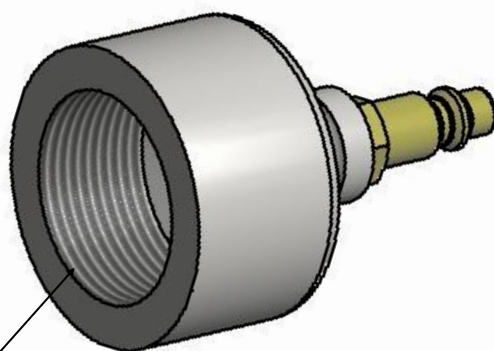

1 1/4" Female NPT (P/N 22999)
or
3/4" Female NPT (P/N 23001)

P/N: 22999 & 23001

When commissioning the Amerex Modular Dry Chemical System, upon initial installation, and at each (6) six month service, the V250 Agent Distribution Network must be purged with dry air or nitrogen at approximately 90 PSI (620 kPa) using the Distribution Hose Blowout Adapters.





OPEN END PUMP WRENCH

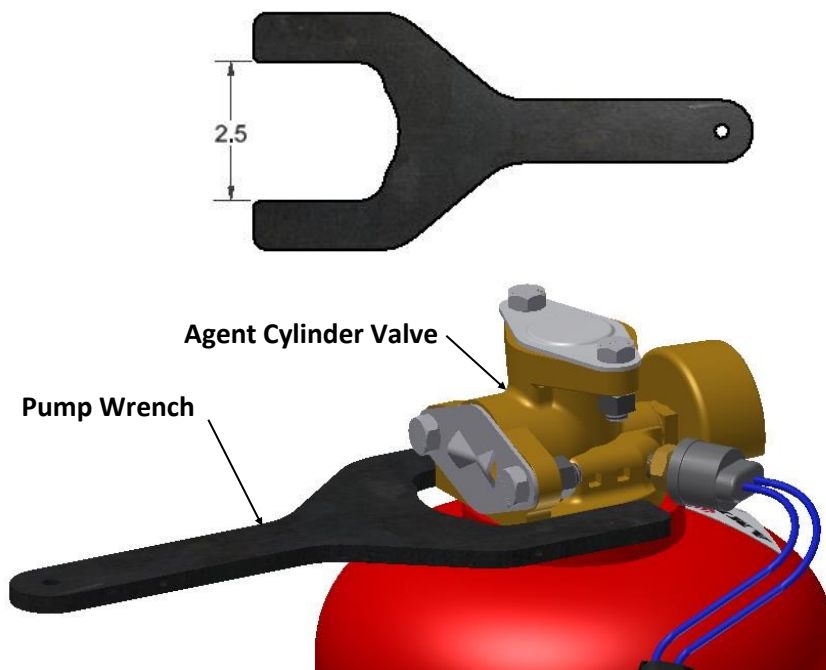

The 2 ½" Pump Wrench is used to remove or reinstall the Agent Cylinder Valve In the Agent Cylinder. It can be purchased from McMaster-Carr or other hardware supply stores. The Pump Wrench should be less than .30" in thickness for proper fit on the Agent Cylinder Valve.





PNEUMATIC ACTUATION TEST ADAPTER

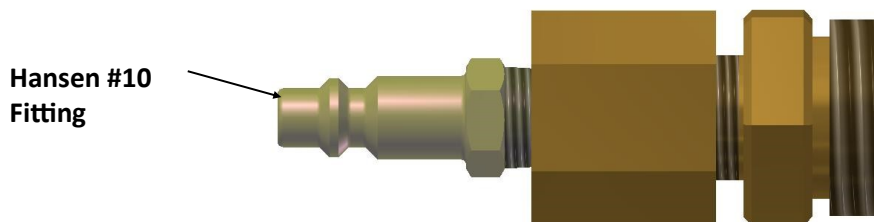

P/N: 10895

The Actuation Network Test Adapter is used in place of a Nitrogen Cylinder to purge the Pneumatic Actuation Network with dry air or nitrogen at each Manual Actuator, Electric Nitrogen, or Manual/Electric Actuator location. It is also use to leak check the actuation network and to verify that the control heads will activate as designed.





RECHARGE ADAPTER

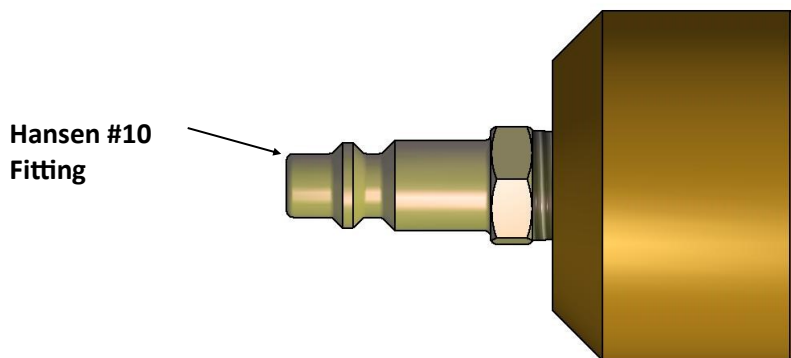

P/N: 23065

The V250 Recharge Adapter is used to pressurize the V250 Agent Cylinder after a discharge or maintenance.





REPLACEMENT END OF LINE MODULE

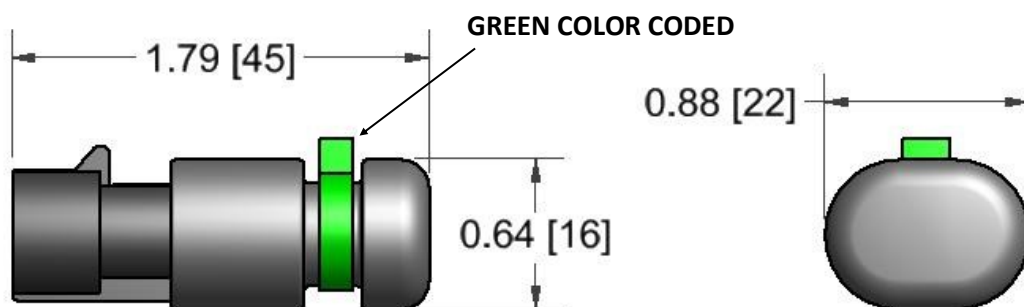

P/N: 14010

The end of line module completes the two class B detection circuits. Two are furnished with each Safety Net circuit monitor or control panel.

Available as singles (14010) or in bulk (14010-100).





REPLACEMENT BATTERY



P/N: 18156

The circuit monitor (P/N 17308/17309) and control panels (P/N 17310/17311) contain a nickel metal hydride back up battery to maintain vehicle protection in the event of loss of the main vehicle power source for up to 24 hours. It takes approximately 8 hours to fully charge this battery from a fully discharged state. The battery is DOT compliant for shipping purposes.

Battery has a one (1) year shelf life and two (2) year service life for a total of three (3) year maximum life.





DRIVER PANEL REPLACEMENT BATTERY



P/N: 19667

The replacement battery is used with the SafetyNet Driver Panel (P/N 16390) and is composed of 7 nickel metal hydride cells. Nominal voltage is 8.4 VDC for this product. It takes approximately 8 hours to fully charge this battery from a fully discharged state. The battery is DOT compliant for shipping purposes.

Battery has a one (1) year shelf life and two (2) year service life for a total of three (3) year maximum life.





WARRANTY INFORMATION

Genuine factory parts are available to insure proper maintenance - use of other manufacturer's parts releases Amerex of its warranty obligations. Amerex parts have machined surfaces and threads which are manufactured to exacting tolerances. O-rings, hoses, nozzles and all metal parts meet precise specifications and are subject to multiple in-house inspections and tests for acceptability. The Amerex Warranty is voided by use of generic, off-the-shelf or substitute parts. **DO NOT SUBSTITUTE!**

Amerex Corporation does not install, service, maintain nor recharge Vehicle Fire Suppression Systems. This Parts Book and the Amerex system service manuals are published as guides to assist qualified personnel in the proper selection of parts and the design, installation, maintenance and recharge of Amerex Vehicle Fire Suppression Systems only. **FAILURE TO USE Amerex REPLACEMENT PARTS OR FOLLOW THE SERVICE MANUAL INSTRUCTIONS COULD CAUSE MALFUNCTION OF THE SYSTEM RESULTING IN SERIOUS INJURY OR PROPERTY LOSS.**

FULL TERMS AND WARRANTY CONDITIONS CAN BE FOUND AT: <https://www.amerex-fire.com/terms-and-conditions>

