



Pre-Engineered Systems

Training

Kitchen and Zone Defense Suppression Systems

Date: ____/____/____

Name: _____

Company Name: _____

Address: _____

Phone Number () - _____

Email _____

Be certain to legibly print all information.

Signature _____

By signing here I affirm that I am the person attending the class and completing the certification exam.



**DESIGN, INSTALLATION,
MAINTENANCE & RECHARGE
MANUAL**

NO. 20150

**AMEREX
RESTAURANT
FIRE SUPPRESSION SYSTEM**

**TESTED AND LISTED BY
UNDERWRITERS LABORATORIES
TO UL STANDARD 300
and
UNDERWRITERS LABORATORIES OF CANADA
ULC/ORD 1254.6-1995**

**AMEREX CORPORATION
Post Office Box 81
Trussville, Alabama 35173-0081
Phone: (205) 655-3271 Fax: (205) 655-5112
e-mail: sales @amerex-fire.com web page: www.amerex-fire.com**

No part of this manual may be reproduced or transmitted in any form or by any means electrical or mechanical, including photocopying or by any storage and retrieval system without the expressed permission in writing from Amerex Corporation.

A Factory Trained and Authorized Distributor must perform the installation and service of any Amerex Restaurant Fire Suppression System in strict accordance with this manual.

December 2008

LIMITED WARRANTY

Amerex warrants its Restaurant Fire Suppression Systems to be free from defects in material and workmanship for a period of three (3) years from the date of purchase. During the warranty period, any defective part will be repaired or replaced (at Amerex option). This warranty is valid only if each system is installed, serviced and maintained by an Amerex authorized distributor in strict accordance with Amerex Manual No. 20150. All work must be performed using genuine Amerex replacement parts. This Warranty does not cover defects resulting from modification, alteration, misuse, exposure to corrosive conditions or improper installation or improper maintenance. Warranties on component items not manufactured by Amerex are provided by others whose warranty, evaluation and judgment will be final.

ALL IMPLIED WARRANTIES, INCLUDING BUT NOT LIMITED TO, WARRANTIES OF FITNESS FOR PURPOSE AND MERCHANTABILITY, ARE LIMITED TO THE TIME PERIOD AS STATED ABOVE. IN NO EVENT SHALL AMEREX CORPORATION BE LIABLE FOR INCIDENTAL OR CONSEQUENTIAL DAMAGES. Some states do not allow limitations on how long an implied warranty lasts or the exclusion or limitation of incidental or consequential damages, so that the above limitations or exclusions may not apply to you.

Amerex Corporation neither assumes nor authorizes any representative or other person to assume for it any obligation or liability other than as expressly set forth herein. This Warranty gives you specific legal rights, and you may also have other rights that vary from state to state. To obtain performance of the obligation of this Warranty, write to Amerex Corporation, P. O. Box 81, Trussville, Alabama 35173-0081, USA for instructions.

THE NEW MANUAL – WHAT IS NEW?

This NEW Restaurant Systems Manual carries a new part number, 20150, for it is a combining of the two previous manuals, KP Manual PN 12385 rev. “A” and ZD Manual PN 16640. The combining of the two manuals does not eliminate any of the limitations of system requirements of the original two manuals, but strives to organize the information into a comprehensive order with additional informative information for greater clarity and understanding.

Some of the changes you will notice in the new manual are made to reduce cost of inventory, printing, manufacturing, ordering and returns. The first item you will notice is the change in nomenclature, **KP 375** or **ZD 375** Agent Cylinder Assemblies are now referred to as a **Model 375** Agent Cylinder Assemble. Now there is only one part number per **Model** of Agent Cylinder Assembly. No longer do you have to order a different part number for a **KP** or **ZD** Agent Cylinder Assembly nor do you have to stock two cylinders the same size simply because one is for a **KP** system and one is for a **ZD** system.

Closer examination of the new manual will reveal that the original configured MRM required that you purchase a MRM and an enclosure (painted or stainless steel) separately. The new MRM II is supplied pre-installed in an enclosure (painted or stainless steel) ready to mount on the wall. The new MRM II incorporates the use of a new ratcheting take up for the automatic detection line. The original MRM used a manual take up method for the cable tensioning and was part number 11977. The original MRM version is no longer in production, however if a replacement for an existing unit is needed or if you are ordering a “Cabinet” enclosure (PN 11978) you can still order part number 11977 as a replacement or to use in the “Cabinet” enclosure. The part number now supplies a MRM II unit without the enclosure, but with the new ratcheting take up. It is 100% interchangeable with the original MRM.

The new manual will still contain service and maintenance instructions for the original style MRM. Anytime you see a heading that says MRM, it is referring to the original style unit. If the information is good for both style units it will say MRM / MRM II. The following arrangement, MRM / MRM II / PRM, indicates that the information is good for all three units.

Due to the combining of the two manuals the following substitutions should be used as follows:

KP Manual PN 12385 is superseded by Restaurant Manual PN 20150

ZD Manual PN 16640 is superseded by Restaurant Manual PN 20150

ZD 275 Agent Cyl. Asy. PN 17102 is superseded by Model 275 Agent Cyl. Asy PN 16921

ZD 375 Agent Cyl. Asy. PN 16650 is superseded by Model 375 Agent Cyl. Asy PN 13334

ZD 475 Agent Cyl. Asy. PN 17474 is superseded by Model 475 Agent Cyl. Asy PN 17397

KP/ZD 375 Mounting Bracket PN 16085 is superseded by 375 Mounting Bracket PN 17690

TABLE OF CONTENTS

Section 1 – General Information

UL Listing	1-1
Design	1-1
General Information Zone Defense	1-2
Definition of Terms	1-3 to 1-6
Revision Record	1-7

Section 2 – System Components

Kitchen Wet Chemical Agent	2-1
Agent Cylinder/Assembly Models 275 / 375 / 475	2-1
Cylinder Mounting Bracket	2-2
Distribution Hose (DISCONTINUED).....	2-2
Agent Cylinder/Assembly Model 600	2-2
Cylinder Valve Assembly Model 600	2-3
Cylinder Mounting Bracket Model 600	2-3
Discharge Fitting Kit KP 600	2-3
Pneumatic Actuator	2-3
MRM / MRM II.....	2-4
PRM.....	2-5
Detection Tubing	2-5
End of Line Fitting	2-5
Tubing Support Clip	2-5
Low Pressure Indicator	2-5
Nitrogen Actuation Cylinder	2-6
Enclosure MRM	2-6
Cabinet	2-6
Actuation Hose & Discharge Nozzle	2-7
Nozzle Swivel Adapter & Nozzle Caps	2-7
Detector	2-8
Test Links	2-8
Corner Pulley	2-8
Cable & Eyebolt Support.....	2-8
JOB & Globe Fusible Links	2-9
Conduit Offset	2-9
Linear Fusible Link Termination Kit	2-9
Cable Segment – Link to Link	2-9
Manual Pull Station	2-10
Adapters	2-10
Quick Seal Compression Fitting.....	2-10
Mechanical Gas Valve	2-11
Electric Gas Valve.....	2-11
Manual Reset Relay.....	2-11
Mechanical Gas Valve Kit.....	2-12
ASCO Mechanical Gas Valve	2-13
Ansul Mechanical Gas Valve	2-13
Snap Action Switch	2-14
Vent Plug	2-14
Horn & Strobe	2-14
Electrical Control Head (ECH)	2-15
Kitchen Hood Fastener	2-16
Flexible Hose	2-17

Section 3 – KP Design

Duct Protection Limitations – Single Nozzle	3-1
Duct Protection Limitations – 2 Nozzle	3-2
Duct Protection Limitations – 3 Nozzle	3-3
Transition Limitation.....	3-1 & 3-3
Nozzle Location & Aiming (Special for Short Vertical Rise Duct)	3-4
Duct Protection Limitation – Multiple Nozzle	3-4
Plenum Protection Limitations	3-5
KP APPLIANCE PROTECTION	
Fryer Protection	3-6, 7 & 8
Range Burner Protection	3-9, 10, 11 & 12
Wok Protection.....	3-12
Griddle Protection	3-13, 14 & 15
Char-broiler Protection.....	3-16
Lava Rock Protection.....	3-16
Solid Fuel Appliances	3-17
Upright Broiler Protection.....	3-18
Salamander	3-18
Char-Broiler Protection	3-19
Nieco 9025 Chain Char-Broiler	3-20
Duke FBB Chain Char-Broiler	3-21
Duke Char-Broiler+ Duke Hood	3-22
Back Shelf Protection	3-23, 24, 25, 26 & 27
Nozzle Application Chart.....	3-28
Agent Cylinder Selection.....	3-29
Actuation Network Limitations.....	3-29
General Piping Requirements.....	3-30
Distribution Network – Single Cylinder.....	3-31
Distribution Network – Twin Cylinder	3-32
KP Distribution Piping	3-33, 3-33A
Spot Detection Network Limitations (MRM / MRM II).....	3-34
Linear Fusible Link Limitations – Spot Detection	3-35
Linear Fusible Link Detection Network – Lanyard System	3-36
Fusible Link Selection	3-37
PRM Limitations	3-37
Manual Pull Station Network Limitations.....	3-38
Dual MRM Installation for Single Hazard	3-38A
Mechanical Gas Valve Applications.....	3-39
Electric Gas Valve Applications	3-40
Wiring Diagrams	3-41
Snap Action Switch Applications.....	3-42

Section 3 – ZD Design

System Design – General.....	3-43
Zone of Protection	3-44, 45 & 46
Distribution Network – Single Cylinder.....	3-47
Distribution Network – Twin Cylinder	3-48
Zone Defense Piping Limitations	3-49 & 50
Detection Network Limitations	3-51

Section 4 – System Installation

General	4-1
Installing the Agent Bracket & Assembly Model 275, 375, 475.....	4-1 & 4-2
Installing the Agent Bracket & Assembly Model 600.....	4-2
Installing the Pneumatic Actuator.....	4-3
Installing Cylinder Enclosure	4-3
Installing the PRM & Detection Tubing	4-4 & 5
Installing Detection Tubing Termination Fitting	4-6
Installing the MRM / MRM II.....	4-7 & 8
Setting the MRM II	4-9
Setting the MRM	4-10
Installing the Linear Fusible Link Detection Network	4-11
Installing the Manual Pull Station (MRM or PRM).....	4-12
Recessed Installation of Manual Remote Pull Station.....	4-12 & 13
Installing the Actuation Network - Limitations	4-14 & 15
Installing the Distribution Piping Network.....	4-16
Installing High Temperature Blow-off Cap	4-17
Installing the Mechanical Gas Valve (MRM or PRM)	4-17, 18 & 19
Installing the Electrical Gas Valve (MRM or PRM).....	4-20
Installing the Mechanical Gas Valve Kit	4-21
Installing the Snap Action Switch (MRM or PRM).....	4-22
Installing the Electrical Control Head (ECH)	4-23
Installing a Nut & Stub Style Fastener	4-24 & 4-25
Installing a Flexible Nozzle Branch Hose	4-26

Section 5 – System Testing

Detection Network Testing.....	5-1
Manual Pull Station Testing & Mechanical Gas Valve Testing.....	5-2
Distribution Piping Network Testing	5-2
Electrical Gas Valve Testing	5-3
Electrical Control Head	5-4

Section 6 – System Maintenance

Maintenance Requirements	6-1, 2 & 3
--------------------------------	------------

Section 7 – System Reset & Recharge

Reset Procedures for MRM / MRM II	7-1
Reset Procedure for PRM	7-2
Recharge Procedure Model 275 / 375 / 475 Cylinder Asy	7-3
Recharge Procedure KP 600	7-4 & 5
Nitrogen Cylinder Recharge.....	7-6, 7 & 8
Reset Procedure for the ECH	7-9

MSDS Sheet Kitchen Wet Chemical Agent

Appendix A

Appendix B

SECTION 1

GENERAL INFORMATION

MANUAL P/N 20150

AMEREX

RESTAURANT

FIRE SUPPRESSION SYSTEM

Tested and Listed by
Underwriters Laboratories, Inc.
to UL Standard 300
EX 4658

Tested and Listed by
Underwriters Laboratories of Canada
to ULC/ORD 1254.6-1995

December 2008

GENERAL INFORMATION

The Amerex KP / ZD Series Restaurant Wet Chemical Fire Suppression System is designed and has been tested to provide fire protection for commercial cooking operations covering the hood, ducts, plenum and appliances. Amerex Restaurant Fire Suppression Systems are a pre-engineered type as defined in NFPA 17A – Standard for Wet Chemical Extinguishing Systems. It is manufactured by the Amerex Corporation, Trussville, Alabama.

It is essential that all installations of the Amerex KP / ZD Series Systems be performed in compliance with this manual. **Those individuals responsible for the design, installation, operation and maintenance of the Amerex Restaurant Fire Suppression System must be trained by Amerex and hold a current Amerex Certificate.** All piping limitations, nozzle coverages, detector placements, etc. have been proven and established through exhaustive testing by Underwriters Laboratories, Inc. Use of components other than those referenced in this manual, or installations exceeding limitations stated in this manual will void all of the Amerex KP / ZD Series System listings.

LISTINGS:

The Amerex KP / ZD Series Fire Suppression Systems are a listed pre-engineered fire extinguishing systems. The KP & ZD systems are listed with Underwriters Laboratories, Inc. – USA per UL 300 fire test specification; Underwriters Laboratories of Canada, Inc. per ULC/ORD 1254.6 – 1995 and Loss Prevention Certification Board – UK per LPS 1223 rev. B. Testing required for listings under these standards involve live fire tests under specific conditions involving commercial kitchen hoods, ducts and appliances. Each test fire is allowed to reach its maximum intensity before agent is discharged. Each test was repeated using both maximum and minimum piping, variations in agent storage cylinder pressure to simulate maximum and minimum temperature ratings. Duct fire tests were extinguished with fans off and fans on; dampers open and closed. Splash tests for various appliances were conducted to assure that discharge of the agent would not cause excessive splashing of hot grease to provide greater employee safety during commercial cooking operations.

UL Standard 300 introduces a series of tests by specifically addressing the use of high efficiency fryers, ranges, woks and the unique fire extinguishing challenges that these appliances present.

DESIGN:

The Amerex KP Series Pre-Engineered Fire Suppression Systems consist of mechanical and electrical components to be installed by an Authorized Factory Trained and Certified Amerex Restaurant Fire Suppression Systems distributor. The system is composed of an Agent Cylinder/Discharge Valve charged with Amerex Kitchen Wet Chemical Agent and a Mechanical Release Module (MRM or MRM II) or Pneumatic Release Module (PRM). The quantity of detectors, fusible links, nozzles, corner pulleys, pulley tees and manual pull stations will vary depending on kitchen design.

The system operates either automatically if actuated by a detector or manually if actuated by a manual pull station. Upon system operation, energy sources for the cooking appliances are required to be shut off immediately. Electrical shutdown devices or suitable gas valves are referenced in this manual. Other equipment such as audible/visual signaling devices can be added where required.

The Amerex Restaurant Fire Suppression System suppresses fire in commercial cooking equipment by spraying Amerex Wet Chemical Agent in a pre-determined manner onto cooking appliances and into exhaust ducts, filters and plenum areas. The primary means of fire suppression is either by saponification of surface grease or by cooling the surface of oils and hot metal surfaces with fine droplets of agent, reducing the temperature of the oil and appliance below the auto-ignition point.

Upon system discharge, the exhaust fans should be left on to aid in dispersal of the liquid suppressant that results in cooling the plenum and duct. Any integral make-up or supply air should be automatically shut off along with all cooking appliances. Some local Authorities Having Jurisdiction require exhaust fans to be shut down by the fire suppression system. Check local fire codes, AHJ and Department of Health in the specific area that the system is being installed for special installation requirements.

The Amerex Restaurant Fire Suppression System agent storage cylinders and cartridge shall not be installed in environments below 32° F or above 120° F (0° C to 49° C).

GENERAL INFORMATION – ZONE DEFENSE SYSTEM

The Amerex ZD Series Pre-Engineered System consists of mechanical and electrical components to be installed by an Authorized Factory Trained and Certified Amerex Restaurant Fire Suppression Systems distributor. The system is composed of an Agent Cylinder Assembly charged with Amerex Kitchen Wet Chemical Agent and a Pneumatic Release Module (PRM) or an MRM, MRM II using a linear link detection network.

The system operates either automatically, if actuated by a rupture in the pressurized thermal responsive tubing or by the separation of a thermal link or manually if actuated by a manual pull station. Upon system operation, energy sources for the cooking appliances are required to be shut-off immediately. Electrical shutdown devices or suitable gas valves are referenced in this manual. Other equipment such as audible/visual signaling devices can be added where required.

The Amerex ZD and KP Series Systems use the same components and share the same UL Listings and limits for the protection of the exhaust duct, plenum and dedicated appliance protection. They **do not** share the same piping limitations or installation philosophy. This manual provides the unique limitations which apply to a Zone Defense Fire Suppression System.

What is the basic difference between a KP and ZD System Philosophy?

The Amerex Zone Defense System was developed for the kitchen that changes out its cooking appliances frequently to accommodate the change in menu or cooks. The ZD System provides a detection system and protection system which allows for the moving and rearranging of appliances without changing the fire suppression piping or detection device locations. This is accomplished by using a detection network that will detect a fire no matter where it occurs under the hood and will extinguish cooking appliances located anywhere under the hood, as long as they are inside the “**Zone of Protection**”. Also the appliances must be capable of being extinguished from overhead. Appliances such as upright broilers, salamanders, covered tilting skillets, chain feed pizza ovens, etc. are all appliances that cannot be extinguished from overhead, but require specific nozzles with specific aiming for the individual appliance. The use of a “**back shelf**” over appliances also will block the application of agent from overhead nozzles and therefore requires the use of “**Dedicated Appliance Protection**” for an appliance with a back shelf.

The Amerex Kitchen Protection Fire Suppression System differs from the ZD System in the manner in which it protects appliances and detects a fire under the hood. The KP System uses individual “Dedicated Appliance Protection” for each appliance under the hood requiring protection. A choice of the fire detection method may be a standard thermal link network or one of the two linear detection networks. (PRM or Linear Fusible Link).

The KP & ZD Series Systems have their distinct application use in the field of kitchen protection. They both provide superior protection from the hazards of commercial cooking.

How do I obtain MSDS Sheets?

MSDS sheets may be downloaded for the Amerex Internet Website:

<http://www.amerex-fire.com/msds/msd/10>

MSDS sheets may also be mailed to you by requesting them by phone or mail:

Amerex Corporation
7595 Gadsden Highway
P.O. Box 81
Trussville, AL 35173
Phone: 205/ 655-7602

DEFINITION OF TERMS

ACTUATION NETWORK: Copper tubing, piping, hose, or combination of the three that allows nitrogen to be supplied from the Mechanical Release Module or Pneumatic Release Module to the Agent Cylinder Assembly(s).

AGENT CYLINDER / DISCHARGE VALVE: Pressurized vessel with valve assembly containing Amerex Wet Chemical restaurant fire suppression agent and expellant gas (nitrogen/argon).

AUTHORITY HAVING JURISDICTION (AHJ): The organization, office or individual responsible for “approving” equipment, an installation or a procedure. The phrase “Authority Having Jurisdiction” is used in NFPA documents in a broad manner since jurisdiction and approval agencies vary as to their responsibilities. Where public safety is primary, the “Authority Having Jurisdiction” may be a federal, state, local or other regional department or individual such as a fire chief, fire marshal, chief of a fire prevention bureau, labor department, health department, building official, electrical inspector or others having statutory authority. For insurance purposes, an insurance inspection department, rating bureau or other insurance company representative may be the "Authority Having Jurisdiction"; at government installations, the Commanding Officer or departmental official may be the "Authority Having Jurisdiction".

AUXILIARY EQUIPMENT: Listed equipment used in conjunction with the Amerex Restaurant Fire Suppression System to shut down: power, fuel and make-up air. Auxiliary equipment also operates dampers, sound alarm signals or initiate fire alarm systems.

“BAG TEST”: A means of testing agent distribution piping to guarantee that each nozzle is discharging equal or proper amounts of agent. Upon completion of a system installation, bags are placed over each nozzle and the system is fully discharged. These bags are then weighed and compared for proper agent distribution according to the system design.

BLOW-OFF CAP: A cap (made of rubber or metal with a restraining strap) that covers the nozzle tip to keep grease from plugging the orifice.

BRANCH DUCT: Ductwork for exhaust from a single hood or hazard to a common duct.

NITROGEN CYLINDER: A small, sealed steel cylinder containing nitrogen (refillable by distributor) used to actuate the agent cylinder/discharge valve(s).

CABLE: 1/16” diameter stainless steel cable (7 x 7 strand, 480# tensile strength) used to connect detectors, mechanical gas valves and manual pull stations to the MRM.

COMMON DUCT: Ductwork for exhaust from two or more separate hazards.

CONDUIT OFFSET: A factory formed section of conduit that allows the cable for manual pull stations, gas valves and detectors to make a smooth transition into the Mechanical Release Module or Pneumatic Release Module.

COOKING APPLIANCE: Includes but is not limited to ranges, fryers, griddles and charbroilers.

CORNER PULLEY: A device used with the detection network, mechanical gas valve and manual pull station which allows the cable to change direction 90° and still move freely for system operation.

DAMPER: A valve or plate located within a duct or its terminal equipment for controlling the flow of exhaust gases and air. Damper’s may also be present on cooking appliances.

DEDICATED APPLIANCE PROTECTION NOZZLE: A nozzle dedicated to the protection of a cooking appliance with an enclosed cooking hazard, like an upright broiler, which cannot be protected with “zone of protection” nozzles. Therefore, must be protected with nozzles explicitly listed for that appliance.

DETECTOR: (NFPA 96 “Electrical, pneumatic, thermal, mechanical or optical sensing instrument or sub components of such instruments whose purpose is to cause an automatic action upon the occurrence of some pre-selected event”.): MRM or MRM II: For our purpose this is a thermal-mechanical device consisting of a detector bracket, detector linkage and fusible link which will automatically actuate the fire extinguishing system at a predetermined temperature. PRM: A pneumatic tube that will automatically actuate the fire extinguishing system at a predetermined temperature will be used with the PRM.

DETECTION NETWORK: MRM or MRM II: A continuous cable run through EMT conduit, corner pulleys and detectors that provide a mechanical input to the mechanical release module in order to actuate the system automatically. PRM: A continuous run of pressurized thermal responsive tubing that provides a mechanical input to the pneumatic release module in order to actuate the system automatically.

DETECTOR LINKAGE: The device that supports the fusible link on the cable.

DISTRIBUTION NETWORK: The piping network consisting of supply lines, supply branch lines and nozzle branch lines that serve as a means to deliver agent from the agent cylinder/discharge valves through the nozzles.

DUCT: A continuous passageway for the transmission of air and vapors which, in addition to the containment components themselves, may include duct fittings, plenums and/or other items or air handling equipment.

ELECTRICAL CONTROL HEAD (ECH): A pneumatic assembly which, when connected to the Amerex SR-X Releasing Control Panel, will open up to ten (10) Agent Cylinder / Discharge Valves via the activation of the connected Electric Actuator.

FLOW POINT: The term used to describe the flow capacity of each nozzle. This information is used to determine the number of agent cylinder/discharge valves required for a specific installation.

FUSIBLE LINK: A fixed temperature heat detection device used to restrain the operation of the Mechanical Release Module until the detectors designed temperature is reached. At its designated temperature, the fusible link will separate, releasing tension on the cable, causing the system to discharge.

GAS TRIP ASSEMBLY: A pneumatic device mounted in the MRM, MRM II or PRM, which upon system actuation pulls the cable connected to the mechanical gas valve causing it to close and stop the flow of gas.

GAS VALVE: A mechanical or electrical valve used to shut off the supply of gas to the cooking appliances when the fire suppression system discharges. Such devices are required by NFPA 96 and are to be listed with the system components. Gas valves must be manually reset.

GREASE: Rendered animal fat, vegetable shortening, vegetable oils or any combination thereof, which is used for, or the result of, cooking and preparing food. Grease may be liberated and entrained in exhaust air or may be visible as a liquid or a solid.

GREASE FILTER: A component of the grease vapor removal system that deflects the air and vapors passing through it in a manner that causes the grease vapor concentration and/or condensation for the purpose of collection, leaving the exiting air with a lower amount of combustible vapor.

GREASE TIGHT: constructed and performing in such a manner as not to permit the passage of grease under normal cooking conditions.

HOOD: A device provided for a cooking appliance(s) to direct and capture grease-laden vapors and exhaust gases, and constructed within the requirements of NFPA 96.

INPUT: An event monitored by the Mechanical Release Module (MRM or MRM II) or Pneumatic Release Module, which causes a corresponding output(s). (Example: A detector senses fire [input] and the system discharges [output] and trips the gas valve [output]).

INSPECTION: A “quick check” to give reasonable assurance that the system has not been tampered with and is in a charged, operable condition.

LISTED: Equipment, materials, components and parts included in a list published by an organization acceptable to the AHJ (Authority Having Jurisdiction) and concerned with product evaluation, which maintains periodic inspection of production of listed equipment or materials and whose listing states either that the equipment or material meets appropriate standards or has been tested and found suitable for its use in the specified manner. The listing may not be considered valid unless so labeled.

MAINTENANCE: A “thorough check” to give maximum assurance that the extinguishing system will operate as intended. Design parameters should be closely examined for hazard changes since the last inspection, parts and components should be closely examined and tested or replaced if necessary.

MAKE-UP AIR: Air that is brought into the hazard from outside of the area, using a dedicated fan, to aid in the exhaust of grease-laden vapors.

MANUAL PULL STATION: The device that allows the system to be manually discharged either at the hazard or from a remote location.

MECHANICAL RELEASE MODULE (MRM / MRM II): An assembly that connects and controls the actuation cartridge, the detectors, the manual pull station(s), the gas valve, the micro-switch(es) and the agent cylinder/discharge valve(s). It receives inputs and activates appropriate outputs – including agent release, auxiliary signals and power or gas shut-off.

SNAP ACTION SWITCHES: A set of dry (unpowered) electrical contacts arranged in various configurations for initiating appropriate output functions such as signal to the building fire alarm, audible/visual remote signal, electrical power shut-off, electric gas valve shut-off.

NOZZLE: The device used to deliver a specific quantity, flow and discharge pattern of fire suppression agent to a specific appliance, duct size or plenum size.

NOZZLE BRANCH LINE: All pipe and fittings leading from the supply branch tee to a system nozzle.

OUTPUT: An action that is initiated by the mechanical release module in responding to a pre-determined input. (Examples: Agent release, power shut-off, remote signal, gas valve closure)

PERIMETER INCHES: The sum of the measurement of each side of a rectangular duct opening. (Example: Duct opening measuring 18” x 9” would have 54 perimeter inches [18 + 18 + 9 + 9 = 54])

PLENUM: The space defined by the filters and the portion of the hood behind the filters.

PNEUMATIC RELEASE MODULE (PRM): This single hazard control mechanism supervises and controls one Fire Suppression System. Proven, rugged mechanical components are reliably set into motion with a simple linear pneumatic detection interface. The control mechanism interfaces with mechanical manual pull station(s), actuation networks, mechanical gas valves, and offers electrical contacts for shutdown functions. Refer to the Design and Installation Manual, P/N 16546 for further details.

PRE-ENGINEERED SYSTEM: Those systems having pre-determined flow rates, nozzle pressures and quantities of agent. These systems have the specific pipe size, maximum and minimum pipe lengths, flexible hose specifications, number of fittings and number of types of nozzles prescribed by a testing laboratory. The hazards protected by pre-engineered systems are specifically limited as to type and size by a testing laboratory based on actual fire tests. Limitations on hazards that can be protected by these systems are contained in the manufacturer’s installation manual, which is referenced as part of the listing.

“PUFF TEST” (or “AIR TEST”): A test to determine that the distribution network piping is clear. The test is conducted by running nitrogen through the piping and confirming that all nozzles are clear.

PULLEY TEE: A device similar to a corner pulley except there is a change in direction on the cable from two manual pull stations or two mechanical gas valves. It unites either two gas valves or two manual pull stations to a single control point.

SALAMANDER BROILER: See upright broiler.

SAPONIFICATION: The reaction of fats and/or oils to alkaline materials, producing soap-like foam. Fire extinguishing agents based on sodium bicarbonate, potassium bicarbonate, potassium acetate and potassium carbonate will cause saponification when discharged onto hot grease. Rendered animal fat and oils containing high percentages of saturated fat saponify better than cooking oils containing low percentages of saturated fat.

SERIES DETECTOR: Any detector located between the Mechanical Release Module (MRM or MRM II) and the terminal detector.

SUPPLY LINE: That portion of the agent distribution network piping that runs from the agent cylinder assembly outlet or distributor block to the first tee.

SUPPLY BRANCH LINE: All pipe and fittings leaving the first tee in the system and ending with the last nozzle in the last nozzle branch line.

TERMINAL DETECTOR: The last detector (or only detector) in the detection network. It is at this point that the cable for the detection network ends or is terminated.

TEST LINK: This device is used in place of a fusible link in order to easily test the detection network. The test link is easily cut, simulating a fusible link separating under fire conditions. It is usually located on the terminal detector and is used solely for test purposes.

UPRIGHT BROILER: A cooking appliance using intense radiant heat and conductive heat with the foot and/or the radiant heat source not being limited for a horizontal mode. Most of these cooking appliances incorporate a removable drip tray and may be used specifically for holding or warming foods.

VENT CHECK: A device installed in the actuation network that is used to safely relieve pressure and to prevent a slow, unwanted build-up of pressure in the actuation network.

ZONE of PROTECTION – A horizontal foot print below and within the perimeter of the hood, in which the cooking appliances are to be positioned. The discharge nozzles within the “Zone of Protection” are spaced at pre-determined intervals to provide protection for eligible appliances within the “Zone of Protection” without the need for re-aiming or repositioning of nozzles. An exception to this practice is for dedicated appliances such as the upright broiler. Dedicated appliances require appliances specific nozzles protection, which will require further review after movement of the appliance for possible re-aiming or repositioning of nozzle(s).

SECTION 2

SYSTEM COMPONENTS

MANUAL P/N 20150

AMEREX

RESTAURANT

FIRE SUPPRESSION SYSTEM

Tested and Listed by
Underwriters Laboratories, Inc.
to UL Standard 300
Effective November 21, 1994
EX 4658

Tested and Listed by
Underwriters Laboratories of Canada
To ULC/ORD 1254.6-1995

December 2008

SYSTEM COMPONENTS

AMEREX KITCHEN WET CHEMICAL AGENT is special formulated potassium acetate based solution specifically designed for use on cooking grease and cooking oil fires. Amerex Kitchen Wet Chemical Recharge is shipped in plastic pails with each pail marked with date and batch code.

Shipping weight: P/N 16924 2.75 Gal. Pail – 30 lbs. (13.6 kg) – CH547
P/N 12866 3.75 Gal. Pail – 42½ lbs. (19.277 kg) – CH544
P/N 17450 4.80 Gal. Pail – 51.24 lbs. (23.24 kg) – CH656
P/N 15416 6.14 Gal. Pail – 67 lbs. (29.71 kg) – CH664



WARNING: AMEREX WET CHEMICAL AGENT IS A STRONG ALKALINE MIXTURE, SAFETY GLASSES AND GLOVES SHOULD BE WORN WHENEVER HANDLING THE AGENT. CONTACT WITH SKIN SHOULD BE AVOIDED. IN CASE OF DISCHARGE, THE SOLUTION SHOULD BE CLEANED UP PROMPTLY TO AVOID DAMAGE TO APPLIANCES, HOOD AND DUCT, ALL FOOD IN CONTACT WITH THE AGENT MUST BE DISCARDED. REFER TO THE AGENT'S MATERIAL SAFETY DATA SHEET.

AGENT CYLINDER ASY.
MODEL 275 - (P/N 16921)
MODEL 375 - (P/N 13334)
MODEL 475 - (P/N 17379)

CE MARK / EN3 - AGENT CYLINDER ASY.
MODEL 275 - (P/N 19434)
MODEL 375 - (P/N 16338)
MODEL 475 - (P/N 19435)

Model 275 -16921	U.S.	METRIC
Height	23 5/8 in	60.0 cm
Diameter	9 in	22.9 cm
Weight Full	55 ¼ lb	25.06 kg
Capacity	2.75 gal	10.41 L

Model 375 -13334	U.S.	METRIC
Height	24-13/16 in	63.02 cm
Diameter	10 in	25.4 cm
Weight Full	64-½ lb	29.25 kg
Capacity	3.75 gal	14.2 L

Model 475 -17379	U.S.	METRIC
Height	29 13/16 in.	75.7 cm
Diameter	10 in	25.4 cm
Weight Full	80 ¼ lb	36.4 kg
Capacity	4.80 gal	18.17 L

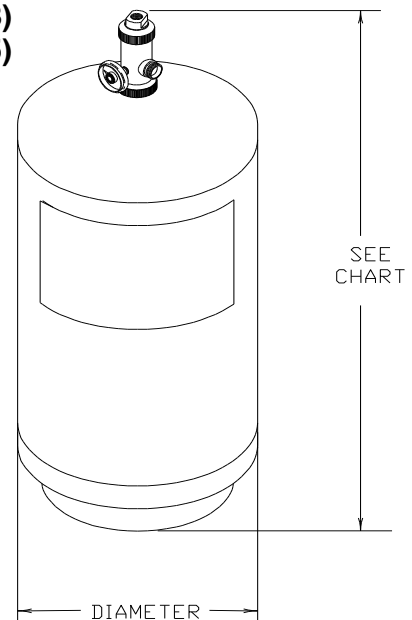

Amerex 275 / 375 & 475 Agent Cylinder Assemblies have 2.72 / 3.75 & 4.80 gallon agent capacity respectively and are shipped factory filled with Amerex Kitchen Wet Chemical Agent. The cylinders are pressurized with dry nitrogen or argon gas to a pressure of 240 psi (1655 kPa) at 70 °F (20°C). The gas charge is the expellant gas which discharges the wet chemical agent through the distributor network.

The machined stainless steel **discharge valve** is actuated pneumatically by the Mechanical Release Module. The valve assembly has a ¼ inch NPT (female) actuation port and a discharge adapter with threads to accept a flexible discharge hose or swivel adapter.

ITEM	DESCRIPTION
1	CAP W/CHECK VALVE
2	CAP NUT
3	O-RINGS (2)
4	PISTON
5	VALVE STEM ASSY
6	SPRING (S. S.)
7	RETAINER NUT
8	COLLAR O-RING
9	VALVE BODY
10	240 PSI GAUGE
11	DOWNTUBE

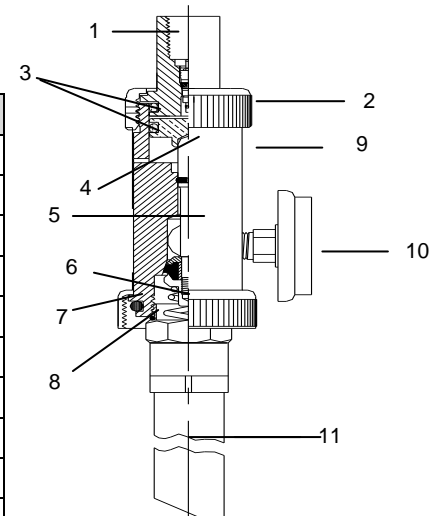

375 CYLINDER MOUNTING BRACKET (P/N 16085)

The mounting bracket is used to secure the KP/ZD 375 Agent Cylinder Assembly to the mounting surface and to connect the discharge valve to the distribution-piping network. The bracket consists of a formed steel assembly with vertical and horizontal supports and an integral pipe thread adapter with 1/2" NPT threads. The pipe thread adapter may be oriented to any convenient outlet position.

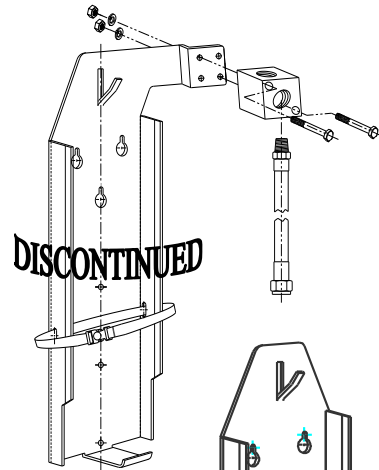

DISTRIBUTION HOSE (P/N 13069)

The distribution hose is used to connect the agent cylinder assembly to the distributor block (P/N 13105). The supply line is connected to the distributor block (included with cylinder mounting bracket).

375 AGENT CYLINDER BRACKET (P/N 17690)

The mounting bracket is used to secure the KP/ZD 375 Agent Cylinder Assembly to the mounting surface. The bracket assembly comes with a S.S. belly strap and a swivel adapter for connection of the valve outlet to the piping network. The bracket is made from formed carbon steel metal and dry painted red.

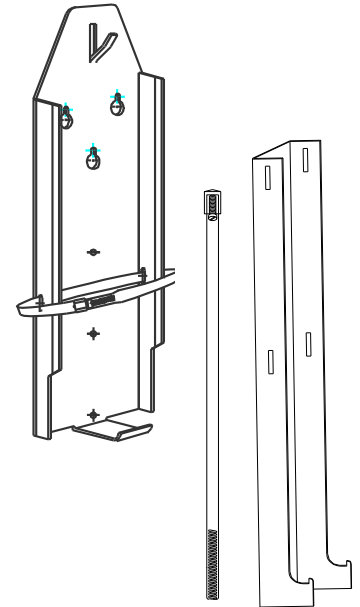

MODELS 275 / 375 & 475 CYLINDER MOUNTING BRACKET(P/N 16920)

The 275 / 375 & 475 Mounting Bracket is used to secure the Models 275/ 375 & 475 Agent Cylinder Assembly to the mounting surface. The Cylinder Mounting Bracket is made from 1/8" thick formed steel and painted red to resist corrosion. The assembly comes with a stainless steel belly strap and a Swivel Adapter for connection to the cylinder valve outlet.

SWIVEL ADAPTER (P/N16901)

The Swivel Adapter connects the distribution piping- 1/2" NPT to the valve outlet.

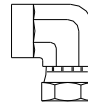

AGENT CYLINDER ASSEMBLY

MODEL 600 (P/N 15196) CE MARK/EN3 MODEL 600 (P/N 16339)
Amerex MODEL 600 – 6.14 Gallon Capacity – Agent Cylinder Assembly is shipped factory filled with Amerex Kitchen Wet Chemical Agent. It is pressurized with dry Nitrogen or argon gas to a pressure of 240 psi (1655 kPa) at 70°F (20°C). The nitrogen charge is the expellant gas which discharges the KP agent through the distribution network. Cylinders are shipped from the factory with a shipping plate installed on the top of the valve to prevent accidental discharge and an anti-recoil plate on the valve outlet to redirect chemical flow should an accidental discharge occur. **BOTH OF THESE PLATES MUST BE REMOVED AT INSTALLATION.**

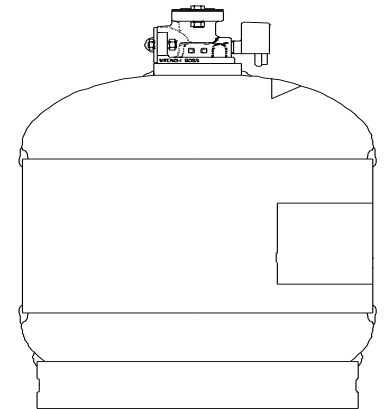

KP600 Agent cylinders are DOT 4BW240, tested to 480 psi (3309 kPa) and require a hydrostatic test every twelve (12) years. The operating temperature of this and other listed components is 32°F to 120°F (0°C to 49°C). The machined, forged brass discharge valve is actuated via a pneumatic actuator. The Mechanical Release Module supplies the N2 required for actuation of one (1) to six (6) KP600 Agent Cylinder Assemblies.

P/N 15196	U.S.	METRIC
Height	27.59 in	70.08 cm
Diameter	12 in	30.5 cm
Weight full	114 lb	51.70 kg
Capacity	6.14 gal	23.2 liter

MODEL 600 CYLINDER VALVE ASSEMBLY (P/N 15060)

The Cylinder Valve Assembly is made with a forged brass body which has been electrolysis nickel plated. The valve stem is made of stainless steel with plated parts. The valve has a 240 psi pressure gauge protected by a plated forged brass gauge guard. The valve controls agent discharge via a spring loaded, internal sealing valve stem that must be depressed from the top of the valve to initiate agent discharge.

ITEM	DESCRIPTION	PART NO.
1	Gauge – 240 PSI	12402
2	Downtube Assembly	15195
3	Spring	10097
4	Valve Stem Assembly	15063
5	Washer – Stainless Steel	10102
6	Screw	10732
7	O-ring	10733

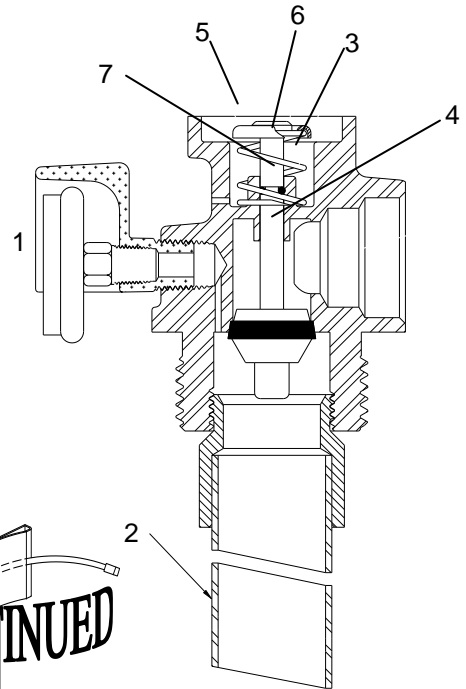

MODEL 600 CYLINDER MOUNTING BRACKET
 (P/N 15166 - DISCONTINUED)
 (P/N 21583 - DISCONTINUED)
 (P/N 23184 - NEW)

The mounting bracket is used to secure the Agent Cylinder Assembly to the mounting surface. The bracket consists of a steel mounting base and stainless steel belly strap. The base is attached to the wall by appropriate means via three holes down the spine or any combination using three holes. A stainless steel worm gear strap is provided to hold the cylinder against the back of the bracket.

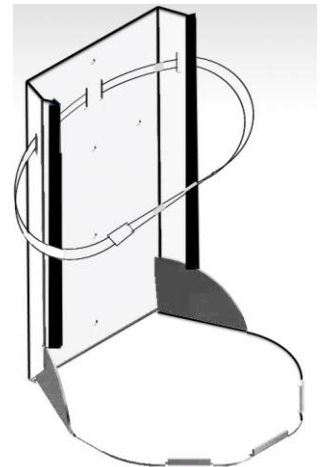
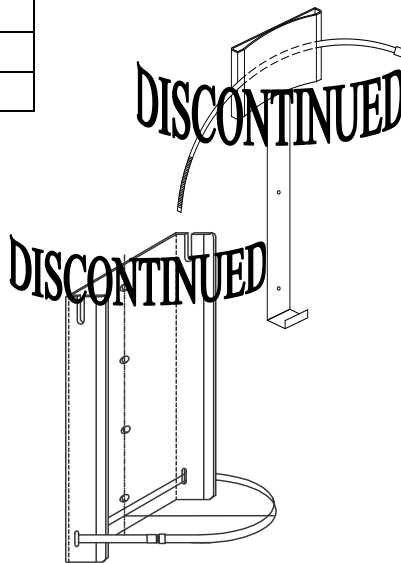

The discharge fitting kit consists of a brass fitting with an o-ring on one end, 3/4 NPT male pipe threads on the other and a stainless steel retaining flange for locking the fitting into place. One discharge fitting kit is required for each KP600 Agent Cylinder Assembly.

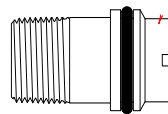

MODEL 600 PNEUMATIC ACTUATOR (P/N 10147)

A pneumatic actuator is required for every KP600 Agent Cylinder Assembly. The actuator is bolted directly to the top of the agent cylinder discharge valve. When actuation occurs at the MRM / MRM II or PRM, the pneumatic pressure from the nitrogen cylinder enters the actuator through 1/4" NPT threaded ports on either side. The actuation pressure forces the piston inside to extend and depress the valve stem of the discharge valve. The piston extends through a retainer washer which allows a spring loaded ball plunger to extend and lock the piston in its extended position. **Resetting is easier than the previous discontinued Actuator P/N15157.**

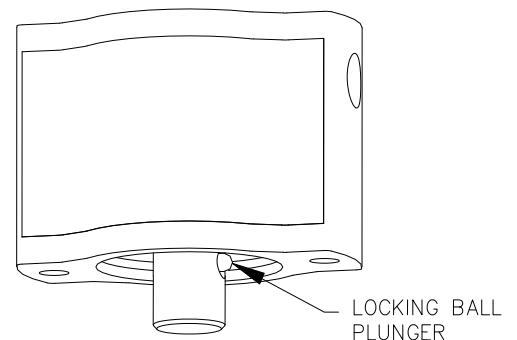

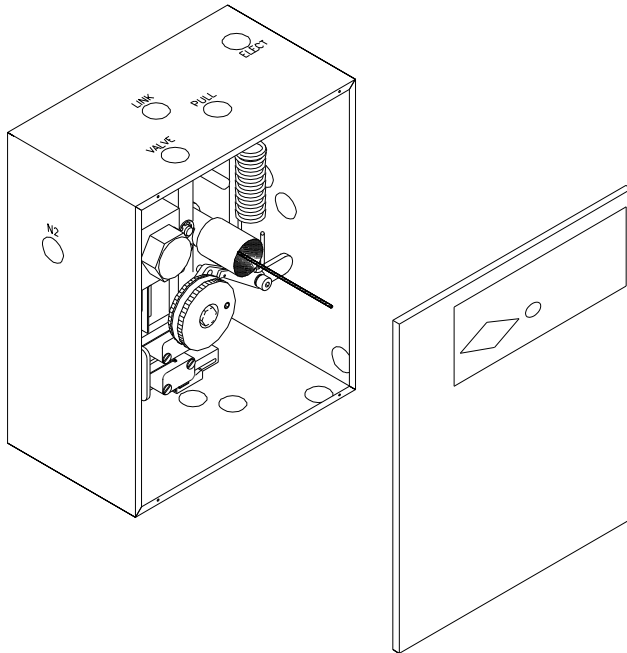

Wide x 5" Deep x 11 3/4" High.

MECHANICAL RELEASE MODULE II (MRM II)

P/N 18000: MRM II with Red-painted Steel Enclosure

P/N 18001: MRM II with Stainless Steel Enclosure

The new MRM II combines the same features and functionality as the original MRM along with increased detection capabilities and a far simpler means of setting the detection cable tension. The MRM II is available in the above configurations, now pre-installed in its own enclosure.

The method of setting the detection cable tension on the **MRM II** does not require the use of any tools (once the cable is locked down into the large, knurled wind-up spool). A large lever to the right of the spool is used to increase the cable tension. Alignment of the bottom edge of the lever with markings on a label on the mounting plate indicates when the proper tension has been achieved. In addition to being easier to set up, lowering cable tension to change out detection links is now also much simpler. The enclosure is 10"

MECHANICAL RELEASE MODULE II - (P/N 11977) WITHOUT AN ENCLOSURE

NOTE: This version of the MRM II is a direct replacement for the old style MRM. It carries the same part number as the original MRM.

The Mechanical Release Module II is used to actuate the agent cylinder discharge valve either automatically or manually by puncturing a nitrogen cylinder.

Automatic release of agent is accomplished when a fusible link detector separates during a fire condition. This causes a spring-loaded plunger to perforate the rupture disc and releases nitrogen through the actuation hose/piping network to the agent cylinder discharge valve(s).

Manual release of agent is accomplished by pulling on a manual pull station which is connected to the Mechanical Release Module II by a cable.

The Mechanical Release Module II is equipped with two **snap action switches**, one (P/N 12524) for electrical signaling, power shutdown and other auxiliary functions and a second (P/N 18312) alarm initiating snap action switch for connection to a fire alarm panel. An additional two snap action switches may be added.

Operation of one or two mechanical gas valves may be accomplished by adding a **Gas Trip Assembly (P/N 12740)**.

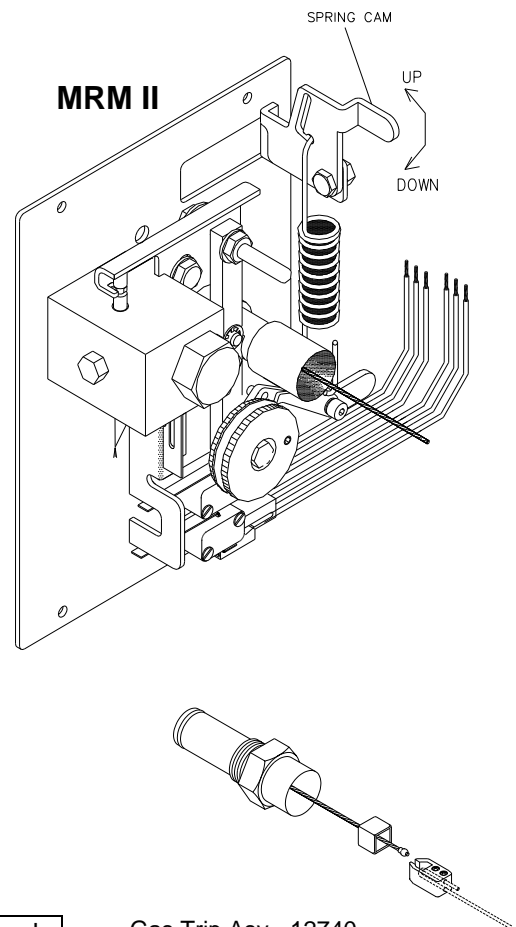

Gas Trip Asy - 12740

The cable for the gas valves, manual pull stations and detection network may be attached to the MRM II from either of two sides (top or bottom).

**PNEUMATIC RELEASING MODULE – (PRM)
(P/N 16547 – PAINTED RED)
(P/N 16795 – STAINLESS STEEL)**

This single hazard control mechanism supervises and controls a Fire suppression system. Proven, rugged mechanical components are reliably set into motion with a simple linear pneumatic detection interface. The control mechanism interfaces with mechanical manual pull station(s), actuation networks; mechanical gas valves, and offers electrical contacts for shutdown functions. A low pressure switch is provided for connection to an alarm panel and/or the optional low pressure indicator. Supplied with the PRM are an End of Line Fitting and two sealing balls.

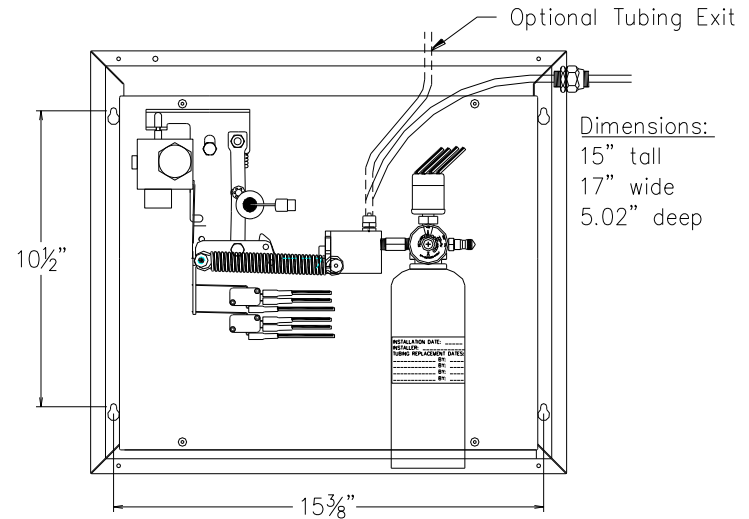

PRM TUBING SUPPORT CLIP (P/N 16501)

The Tubing Support Clip is used in the pneumatic detection network to provide a means of support for the pressurized thermal responsive tubing. A Tubing Clip is required for every 18" of tubing. A Tubing Clip is also required within one inch of the End of Line Fitting.

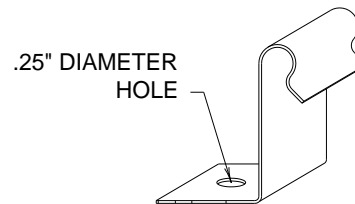

PRM DETECTION TUBING – 1/4" DIAMETER

- P/N 16557 - 25'
- P/N 16551 - 50'
- P/N 16556 - 75'
- P/N 16579 - 100'
- P/N 16552 - 150'
- P/N 16554 - 300'

Pressurized thermal responsive tubing provides a mechanical movement via loss of pressurization anywhere along its entire length that results in system actuation.

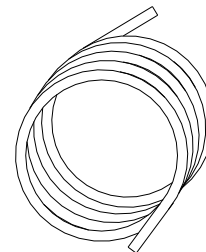

PRM END OF LINE FITTING (P/N 16506)

The "End of Line Fitting" is installed at the end of the pneumatic detection network. The sealing ball must be installed in the tubing at the End of Line Fitting. One End of Line Fitting and two Sealing Balls are supplied with each PRM.

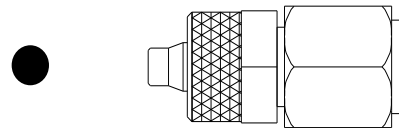

**ACTUATION COPPER TUBING
(50' COIL – P/N 22278)**

1/4" O.D. x 0.049 wall thickness copper tubing
Use this tubing to connect the MRM or PRM to the actuation port of the agent cylinder. Fittings used with tubing are to be brass or steel compression style fittings.

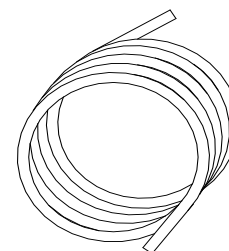

NITROGEN ACTUATION CYLINDER:
10 in³ N₂ Actuation Cylinder (P/N 12856)
15 in³ N₂ Actuation Cylinder (P/N 09956)

The N₂ Actuation Cylinder supplies nitrogen gas pressure to the Agent Cylinder Discharge Valve through the actuation network for the purpose of opening the Agent Cylinder.

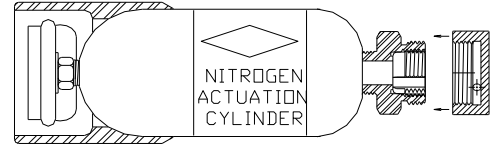

The 10 in³ N₂ Actuation Cylinder, P/N 12856, is charged to 1800 psig (12410 KPa) at 70°F (21°C) and contains enough nitrogen to actuate up to **ten total of Models 275 / 375 / 475** Agent Cylinder Assemblies in any combination **OR** a total of **six** Model **600** Agent Cylinder Assemblies **OR** a **total of six** Agent Cylinders when the **mix contains at least one Model 600** Agent Cylinder Assemblies.

The 15 in³ N₂ Actuation Cylinder, P/N 09956, is charged to 1800 psig (12410 KPa) at 70°F (21°C) and contains enough nitrogen to actuate up to **ten total of Models 275 / 375 / 475 & 600** Agent Cylinder Assemblies in any combination.

A maximum distance of 100 feet (21.3 meters) to the last control head is possible when using the specified copper tubing. Pressure is retained in the N₂ Actuation Cylinder by a gold plated rupture disc. Replacement rupture discs are available, P/N 09958. Only genuine Amerex rupture discs may be used when recharging Nitrogen Actuation Cylinders. Proper charge pressure is indicated by a pressure gauge located on the cylinder's bottom and protected by an impact resistant plastic gauge guard. The N₂ Actuation Cylinder is shipped fully charged from the Amerex factory with a protective shipping cap installed on the outlet threads. The cap must be removed at installation but must remain in place at all other times. (Retain the shipping cap to reuse when recharging the N₂ Actuation Cylinders.) Construction of the N₂ Actuation Cylinder is per DOT 3E. The cylinder is rechargeable by certified Amerex installers and does not require periodic hydro-testing. The 10 in³ Nitrogen Actuation Cylinder may be used in the MRM, MRM II or PRM. The 15 in³ Nitrogen Actuation Cylinder may be used only with the ECH.

Part No.		12856	
Diameter	1.998 in	5.07 cm	
Length	6 3/8 in	16.19 cm	
Pressure @ 70°F	1800 PSI	12411 kPa	
Part No.		09956	
Diameter	1.998 in	5.07 cm	
Length	9.44 in	24 cm	
Pressure @ 70°F	1800 PSI	12411 kPa	

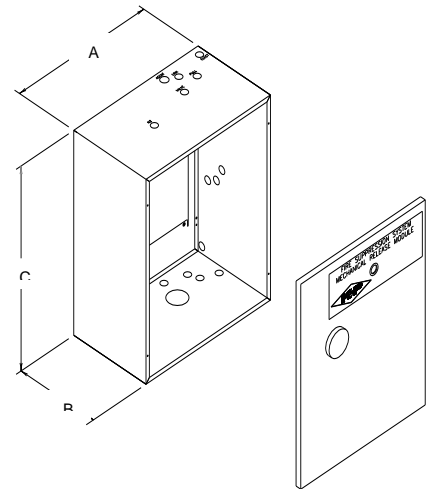

CABINET (P/N 11978)

Stainless steel cabinets are available for single cylinder systems. The cabinet will house one model 275 or 375 Agent Cylinder Assembly, the agent cylinder mounting bracket and a Mechanical Release Module which are purchased separately.

P/N 11978	U.S.	Metric
(A) Width	20 1/2"	52.07 cm
(B) Depth	10 3/4"	27.3 cm
(C) Height	26 1/4"	66.68 cm

275 / 375 / 475 CYLINDER ENCLOSURE (P/N 16814)

Stainless steel enclosure is available for a single model 275 / 375 / 475 Agent Cylinder Assembly. The enclosure will house a 275 / 375 / 475 Agent Cylinder Assembly and **does not require** the use of a cylinder mounting bracket nor a distributor. The enclosure includes a swivel adapter for connection of the cylinder to the discharge piping.

P/N 16814	U.S.	Metric
(A) Width	14"	35.6 cm
(B) Depth	11"	27.9 cm
(C) Height	26 1/4"	66.68 cm

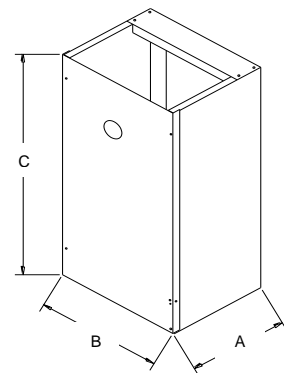

ACTUATION HOSE (P/N 12854) – 16"
ACTUATION HOSE (P/N 16448) – 32"

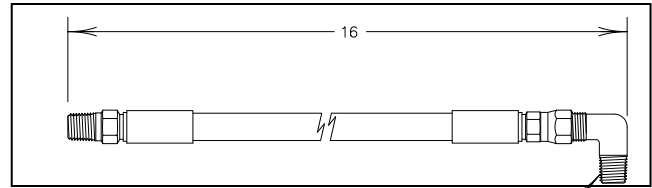

To aid in the installation of systems, an **OPTIONAL** actuation hose is available. This 16" or 32" hose connects the MRM (Mechanical Release Module), MRM II or PRM (Pneumatic Release Module) actuation port to the top of the Agent Cylinder Discharge Valve(s).

DISCHARGE NOZZLES

There are seven (7) types of nozzles listed for use with the Amerex KP/ZD Fire Suppression System. Each has a specific flow rate and discharge pattern. Correct installation, coverage and limitations of each nozzle are listed on the "Nozzle Application Chart" in Section 3, "DESIGN" of this manual.

APPLIANCE TYPE	PART NO.	FLOW POINTS ^{1/4" NPT} _(WITH 5/8" NPT)	MARKINGS
Fryer & Griddle	13729	2	13729 2 x FG
Appliance & Plenum	11982	1	11982 1 x 38
Solid fuel Char-broiler	11983	1.5	11983 1 x 55
Upright Broiler	11984	1/2 ea.	11984 .05 x 71
Range (4 Burner)	14178	2	14178 2 x R
Duct	16416	1	16416 1 x D
Back Shelf Nozzle	16853	1/3	16853 1/3xBS

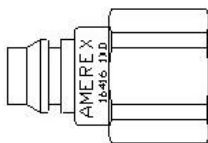

One Piece Body & Tip

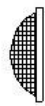

Internal Filter



Snap Ring

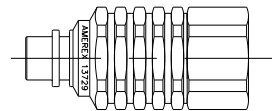

NOZZLE PN 13729
5 RINGS

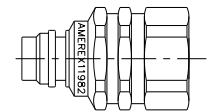

NOZZLE PN 11982
2 RINGS

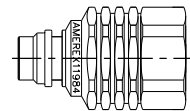

NOZZLE PN 11984
4 RINGS

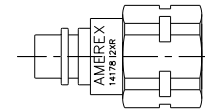

NOZZLE PN 14178
1 GROOVE

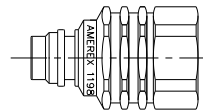

NOZZLE PN 11983
3 RINGS

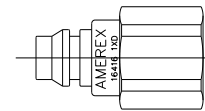

NOZZLE PN 16416
NO GROOVE & NO RINGS

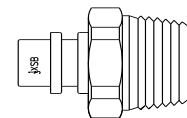

Back-shelf Nozzle P/N16853
3/8 NPT

NOZZLE SWIVEL ADAPTER (P/N 16440)

The swivel adapter (P/N 16440) is an option offered to aid the installation and aiming of the system nozzles. The adapter is composed of three parts – the body, swivel adapter, and retainer nut. All nozzles may be used with the swivel adapter without any change in the nozzle's listing.

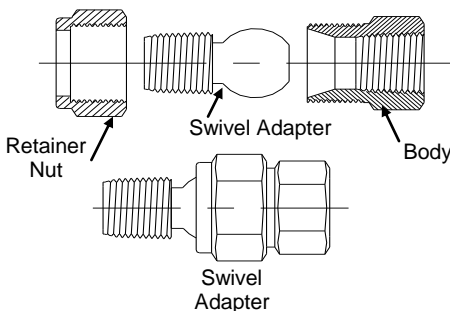

NOZZLE CAPS

Two types of nozzle caps are available for the Amerex KP/ZD Fire Suppression Systems. The Standard Cap (P/N 12334) is provided with every nozzle assembly. This cap can be used in environments not exceeding temperatures of 350°F (176.6°C). Where exposures to temperatures exceed 350°F (176.6°C) the High Temperature Nozzle Cap must be used (P/N 12504).



High Temperature Cap
P/N 12504

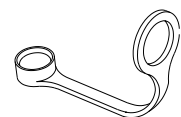

Standard Cap
P/N 12334

DETECTOR BRACKET ASSEMBLY (P/N 12508)

Each detector bracket in the Amerex Kitchen Fire Suppression System is comprised of three parts the detector bracket, detector linkage and two EMT fittings. The fusible link is ordered separately. The bracket serves as support for the linkage and is attached to a rigid surface. The linkage supports the fusible link and a continuous cable run under tension. At a predetermined temperature the fusible link will separate, relieving tension on the cable and actuating the system.

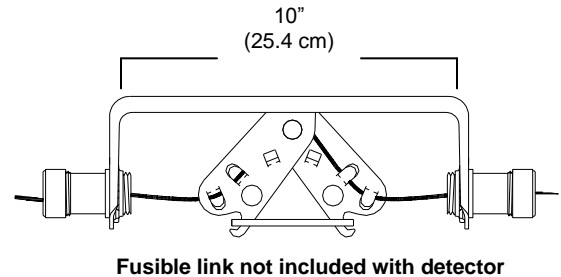

This manual will refer to series and terminal detectors. There is no difference in part numbers or dimensions between series and terminal detectors. A terminal detector is the last or only detector in the network and the cable must be "terminated" there. A series detector is any detector located between the terminal detector and the mechanical release module in the detection network.

TEST LINKS (P/N 12891)

Test links are available for conducting functional tests of the detection system. This device fits the detector linkage in the same manner as the fusible link, is normally placed on the terminal detector and can be cut, simulating a fusible link separating under fire conditions.

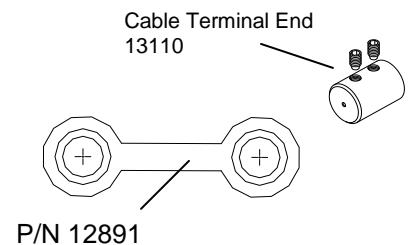

CORNER PULLEY (P/N 12309)

The Amerex Kitchen Fire Suppression System uses a "high temperature" corner pulley to change direction of the cable by 90°. This corner pulley may be used in environments with temperatures up to 700°F (371°C). Mounting holes are provided for anchoring the corner pulley **where allowed by local codes**.

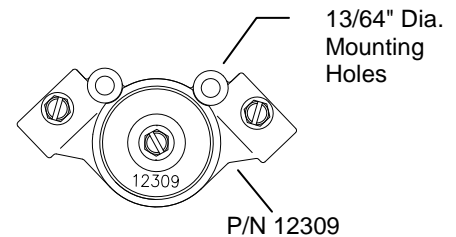

CORNER PULLEY (P/N 16444)

The Amerex Kitchen Fire Suppression System also use a "high temperature" compression corner pulley to change direction of the cable by 90°. (This compression corner pulley [Brooks Model CP5] allows complete assembly of conduit and corner pulleys prior to installing the cable).

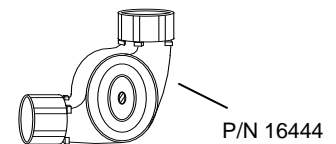

PULLEY TEE (P/N 12506)

A pulley tee is used to change the direction of two cables by 90°. This device can be used with mechanical gas valves and manual pull stations but **not fusible link detectors**. It cannot be used where temperatures exceed the range of 32° - 120°F (0° - 49°C).

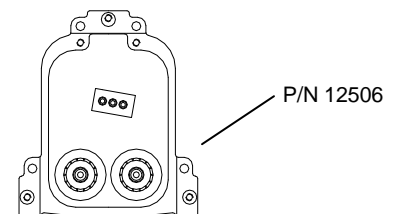

CABLE (P/N 12553)

Cable is used to run from the MRM, MRM II or PRM, through conduit and corner pulleys to detectors, mechanical gas valves or manual pull stations. It is 1/16 inch diameter, stainless steel (7 x 7 – 480# tensile strength) – available in 500 foot (152 m) spools (P/N 12553).

EYEBOLT SUPPORT (P/N 17520)

Eyebolt supplied with one Hex. Nut used to lock the eyebolt into final position. Eyebolt is used to support bare cable run in plenum of the hood in a **Linear Fusible Link Detection System**.



JOB LINKS

Four temperature ratings of the Job Links are available. They are constructed of two metal struts held intension by a small, glass bulb that ruptures at the appropriate temperature rating. The detector bracket (P/N 12508) will support either the Globe Type 'K' fusible links or the Job links, and the same detector limitations apply for both types of detector.

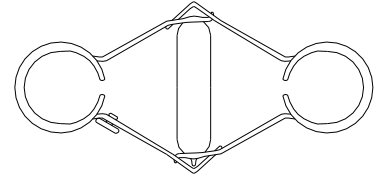

Job Quick Response Link
Load Limit: 1 to 55 lb.

Part No.	Response Type	Link Rating		Max. Ambient Temperature	
		F	C	F	C
16226	Quick	286°F	141°C	225°F	107°C
16227	Quick	360°F	182°C	300°F	149°C
16445	Quick	450°F	232°C	375°F	191°C
16446	Quick	500°F	260°C	425°F	218°C

FUSIBLE LINKS

Four temperature ratings of fusible links are available. They are of the electric solder type link which will melt at a predetermined temperature allowing the two halves of the link to separate.

Part No.	EXPOSURE LIMIT		Link Rating		Max. Ambient Temperature	
	F	C	F	C	F	C
12326	212°F	100°C	150°F	66°C		
12327	280°F	138°C	225°F	107°C		
12328	360°F	182°C	300°F	149°C		
12329	450°F	232°C	375°F	191°C		

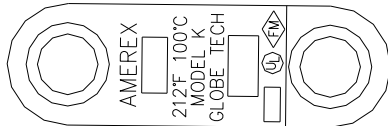

Globe Type "K"

Load Limit: Maximum Load – 50 lbs. (22.68 Kg)
Minimum Load - 3 lbs. (1.37 Kg)

Temperature and year of manufacture are stamped on each link.

CONDUIT OFFSET (P/N 12507)

The conduit offset is used to allow a smooth transition for cable runs into or out of the MRM, MRM II & PRM without using pulley elbows. It may be used with the detection network, manual pull stations or mechanical gas valve actuation network. The use of this device does not reduce the maximum number of corner pulleys allowed in the system. **THE CONDUIT OFFSET MAY ONLY BE ATTACHED TO THE ENCLOSURE OF EITHER THE MRM, MRM II OR THE PRM.**

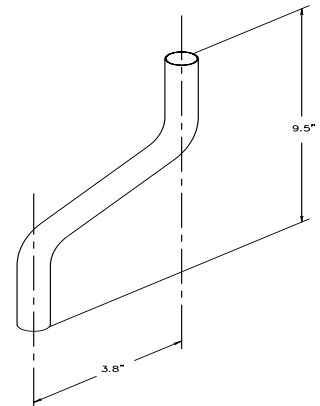

FUSIBLE LINK TERMINATION KIT (PN 17515)

The kit consists of four major components, their part numbers and quantities per kit are provided in the table. The kit contains the necessary cable segments and hardware for the beginning and end termination of the Linear Fusible Link Detection network.

QTY.	DESCRIPTION
1	EMT CONDUIT CONNECTOR 1/2"
1	CABLE SEG. – MRM TO 1 ST LINK – 30 FEET
1	CABLE SEG. – LINK TO TERMINATION
1	HANDY BOX – ½ CONDUIT BOX

MRM TO 1ST LINK

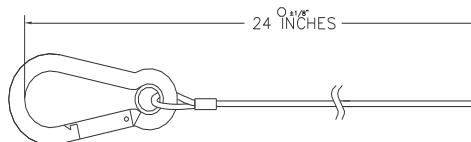
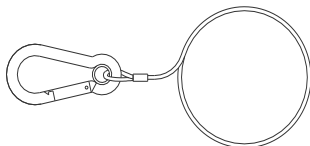

LINK TO TERMINATION

CABLE SEGMENT – LINK TO LINK

PN17354 – 24" CENTERS

PN19155 - 12" CENTERS

The Link to Link cable segment PN17354 insures that the links in the linear fusible link detection system are spaced at the maximum 24" centers to center distance. The Link to Link cable segment PN19155 places links 12" apart center to center. It will assist in locating links in the hood duct opening when the two ducts are an odd distance apart.

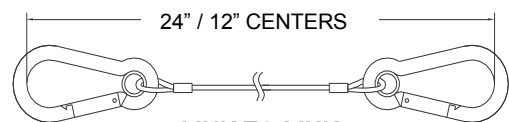

LINK TO LINK

MANUAL PULL STATION (P/N 11993)

Every Amerex Kitchen Fire Suppression System must use at least one Manual Pull Station. This device provides a means of discharging the system manually. Manual Pull Stations should be located in a PATH OF EGRESS and mounted at a height conforming to the local code requirements. The Manual Pull Station may be recessed or surface mounted, see “Installation”, Section 4, Page 11 for details.

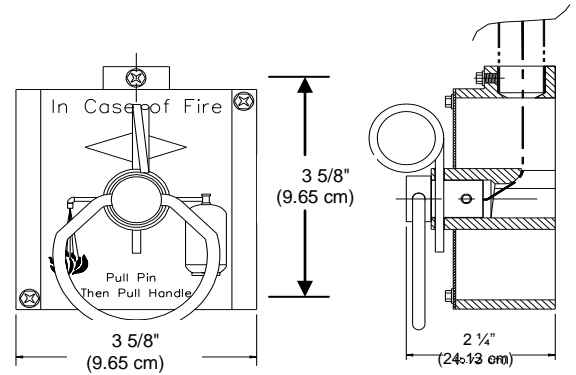

**MANUAL PULL STATION ADAPTER KIT (P/N 14193)
 (for use with manual pull station P/N 11993)**

When recessing the manual pull station the adapter kit compensates for the additional wall thickness and provides an oversized cover for the wall opening.

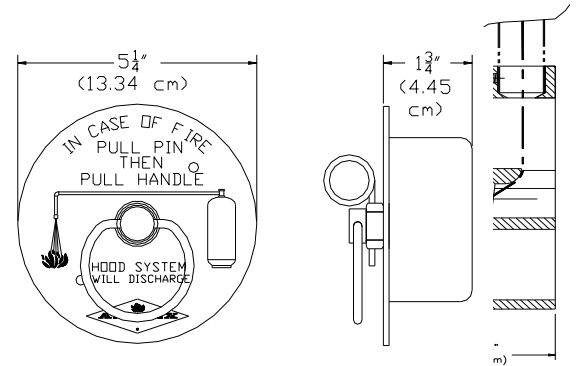

MANUAL PULL STATIONS (OVERSIZED - P/N 14320)

This Manual Pull Station is to be recess mounted. The oversized cover is large enough to cover sheetrock access hole for the standard 4” octagonal box and remain attractive and functional. Manual Pull Stations should be located in the **path of egress** and mounted at a height conforming to the local Authority Having Jurisdiction.

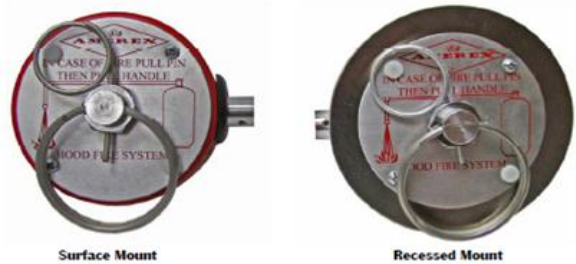

**MANUAL PULL STATION (COMBO PACK)
 (ENG. – P/N 21481)
 (ENG. / FRENCH – P/N 22117)
 (ENG. / SPANISH – P/N 22116)**

This Manual Pull Station may be either surface or recess mounted. The oversized cover is large enough to cover the sheetrock access hole for the standard 4” octagonal box and remain attractive and functional. Manual Pull Stations should be located in the **path of egress** and mounted at a height conforming to the local code requirements.

**“QUICK-SEAL” ADAPTER
 (3/8” pipe – P/N 12276 – HOLE SIZE 1 1/8” DIA.)
 (1/2” pipe – P/N 14204 – HOLE SIZE 1 1/8” DIA.)
 (1” pipe – P/N 18252 – HOLE SIZE 1 5/8” DIA.)**

This listed mechanical bulkhead fitting produces a liquid tight seal around distribution piping where the piping penetrates hoods or ducts. The “quick-seal” adapter is available in 3/8” and 1/2” NPT.

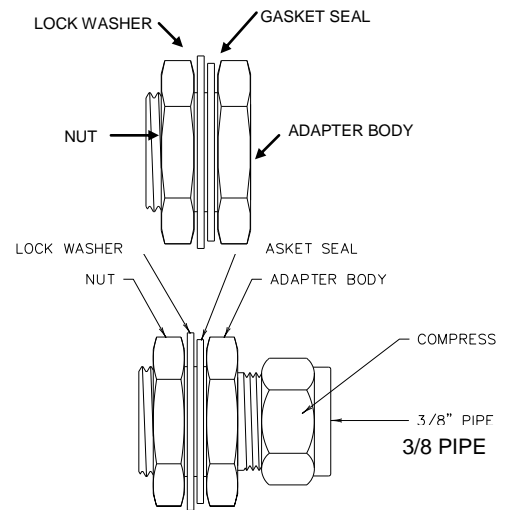

**“COMPRESSION SEAL” ADAPTER
 (3/8” pipe – P/N 12510 – HOLE SIZE 1 1/8” DIA.)
 (1/2” EMT – P/N 12512 – HOLE SIZE 1 1/8” DIA.)**

The compression seal adapter is a “listed mechanical bulkhead” fitting that produces a liquid tight seal around pipe or conduit when making penetrations in a hood or duct. Unlike the quick-seal adapter, the compression seal adapter is not threaded to accept pipe and does not require conduit or pipe to be cut or threaded. It is available in 3/8” and 1/2” sizes.

**“QUICK-SEAL” COMPRESSION FITTING
(1/4” TUBING – P/N 16502 – HOLE SIZE 5/8” DIA.)**

This listed mechanical bulkhead fitting produces a liquid tight seal around the detection tubing where the tubing penetrates the hoods.

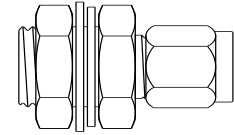

**“QUICK-SEAL” CORNER PULLEY ADAPTER
(EMT THREAD – P/N 22279 – HOLE SIZE 1 1/8” DIA.)**

This listed mechanical bulkhead fitting provides a close connection to a CP5 corner pulley. The close coupling of the two assist in alignment of the conduit run to a detection bracket.

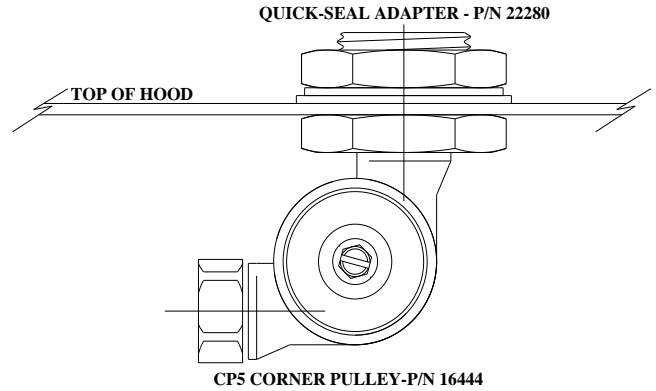

**“QUICK-SEAL” HOLE PLUG & SEAL
(P/N 22280 – FOR HOLE SIZES 1 1/8” TO 1 3/8” DIA.)**

This listed mechanical bulkhead fitting is used to seal unwanted holes in the exhaust hood. Good looking and effective in preventing the loss of grease laden vapors into the kitchen.

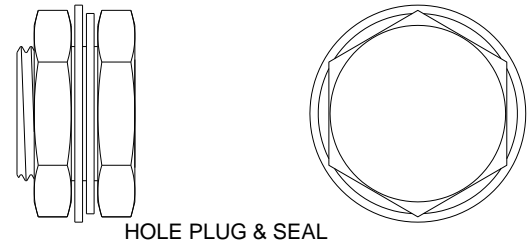

AMEREX MECHANICAL GAS SHUT-OFF VALVE

All Amerex Kitchen Fire Suppression Systems protecting gas-fired cooking appliances must use a gas shut-off valve listed for use with the system. The Amerex Mechanical Gas Valves are held open with a latching device. Upon system discharge a piston in the MRM, MRM II or PRM will pull on a cable connected to the latch in the gas valve actuation box, releasing the latch and allowing the gas valve spring to close the valve. These valves are considered to be “Normally Closed – Held Open”. The valve bodies are made of brass and threaded with female NPT threads on both ends and are UL listed for natural gas and propane in ¾”, 1”, 1¼”, 1½”, and 2” sizes. The Gas Trip Assembly PN12740 is included with all Amerex Gas Valves.

Part No.	Size	A	B	Pressure
12790	¾ in.	10 5/16 in. (26.194 cm)	3 ¾ in. (9.525 cm)	10 PSIG (69 kPa) Max.
12791	1 in.			
12792	1¼ in.	11 9/16 in. (29.369 cm)	4 7/8 in. (12.383 cm)	
12793	1 ½ in.			
12794	2 in.	12 ½ in. (31.75 cm)	6 in. (15.24 cm)	

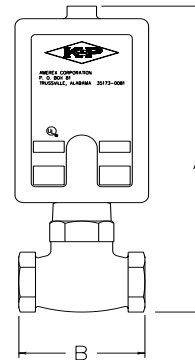

ELECTRIC GAS SHUT-OFF VALVES

Electric gas shut-off valves operate on 110 VAC current which powers a solenoid holding the valve open against a spring. Upon system discharge current to the solenoid is interrupted by a micro switch in the MRM, MRM II or PRM causing the valve to shut. A loss of electrical power will also cause an electrical gas valve to close. A Manual Reset Relay must be used with each electric gas valves. UL listed sizes are ¾”, 1”, 1¼”, 1½”, 2”, 2½”, 3”.

Part No.	Size	Manufacturer
12870	¾ in.	ASCO
12871	1 in.	
12872	1 ¼ in.	
12873	1 ½ in.	
12874	2 in.	
12875	2 ½ in.	
12876	3 in.	

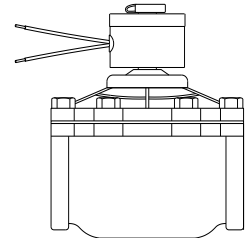

MANUAL RESET RELAY (P/N 12526)

Anytime an electrical gas valve is connected to an Amerex Kitchen Fire Suppression System, a Manual Reset Relay must be used. After an electrical gas valve has closed (either because of system discharge or because of power failure), the gas valve cannot be opened without manually pressing the reset button on the Manual Reset Relay. This operation is to guard against a momentary loss of power closing the valve, extinguishing the pilot lights and allowing gas to escape when power is restored. The Manual Reset Relay is UL listed and has a pilot lamp to indicate its status.

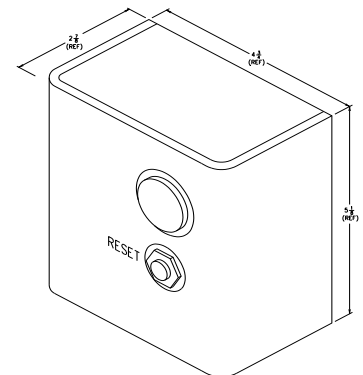

DESCRIPTION: MANUAL RESET RELAY

CONTACT CONFIGURATION: DOUBLE POLE, SINGLE THROW

MINIMUM CONTACT RATING: MTR LOAD = 8 AFL, 48 ALR, 120 VAC

RES LOAD = 8A, 120 VAC

PILOT DUTY 120 VA, 120 VAC

MECHANICAL GAS VALVE KIT (P/N 13622)

The Amerex Gas Valve Kit provides a means of converting a standard “release to close” ASCO gas shut-off valve to a “pull to close” type gas shut-off valve that has been listed with the system. The gas valve is held open by a latching device. Upon system discharge a piston in the Mechanical Release Module will pull on a cable connected to the latch on the gas valve, release the latch and allow the spring in the gas valve to close the valve. The kit must be used with the ASCO valves listed here to complete the UL listing of the Amerex Kitchen Fire Suppression system, ASCO valves are purchased separately. See Section 4, Page 17 & 18 for installation instructions.

NOTE: P/N 13622 ASCO Mechanical Gas Valve Kit is sold separately from the Gas Valve. A gas trip assembly, P/N 12740, is also required when using any of these valves.

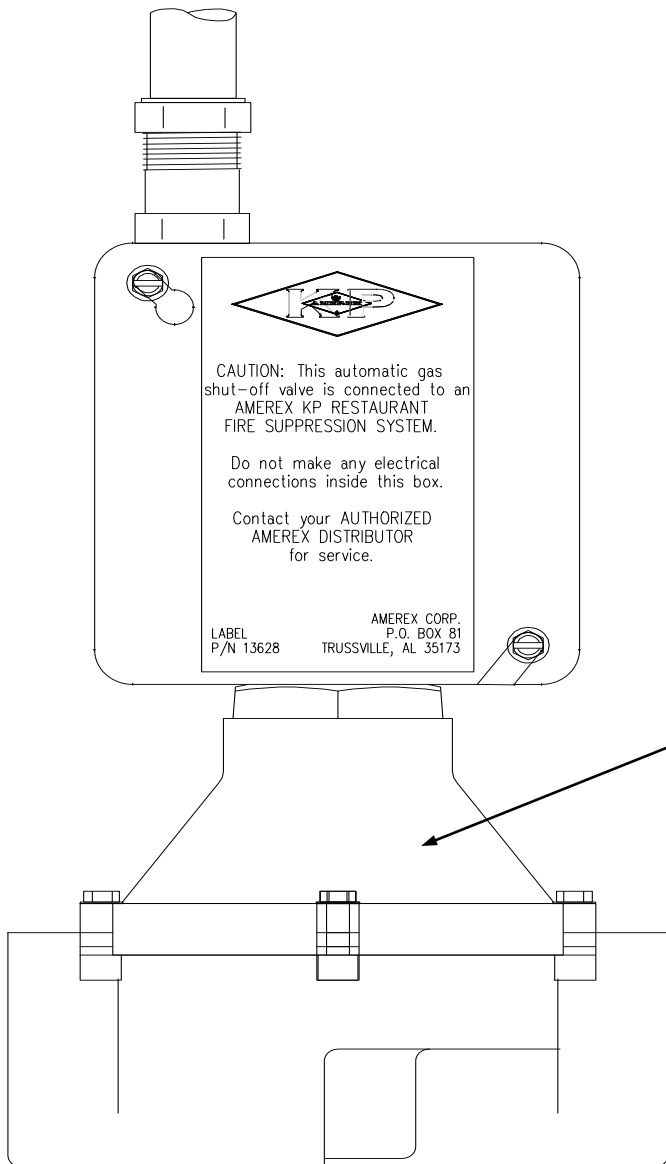

APPLICATIONS		
Amerex Part No.	ASCO Part No.	Size
13772	HV216-585-1	¾"
13773	HV216-585-2	1"
13774	HV216-585-3	1¼"
13775	HV216-585-4	1½"
13776	HV216-585-5	2"

ASCO Gas Shut-Off Valves must be purchased separately

ASCO MECHANICAL GAS VALVES

All Amerex Kitchen Fire Suppression Systems that protect any gas fired cooking appliance must use a “pull to close” type gas shut-off valve, which is listed with the system. The valve is held open with a latching device. Upon system discharge a piston in the gas trip assembly (sold separately) will pull on a cable connected to the latch on the gas valve, release the latch and allow the spring in the valve to close the valve. The ASCO gas shut-off valves approved for use with Amerex Kitchen Fire Suppression Systems are listed below with appropriate part numbers. See “Installing a Mechanical Gas Valve” in the Installation section for instruction on installation.

Note: P/N 12740 Gas Trip Assembly must be purchased separately.

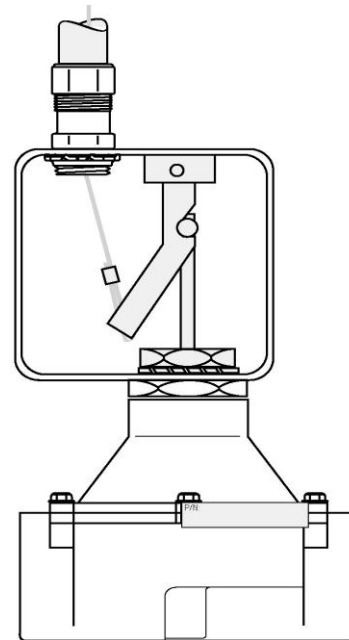

APPLICATIONS		
Amerex Part No.	ASCO Part No.	Size
13777	JV216-587-2	3/4"
13778	JV216-587-3	1"
13779	JV216-587-4	1 1/4"
13780	JV216-587-5	1 1/2"
13781	JV216-587-6	2"
*13782	JV216-587-7	2 1/2"
*13783	JV216-587-8	3"
*Item in stock at Amerex – Trussville, AL		

ANSUL MECHANICAL GAS SHUT-OFF VALVES

All Amerex Kitchen Fire Suppression Systems that protect any gas fired cooking appliance must use a “pull to close” type gas shut-off valve. The valve is held open with a latching device. Upon system discharge a piston in the gas trip assembly will pull on a cable connected to the latch on the gas valve, release the latch and allow the spring in the valve to close the valve. Ansul’s mechanical gas shut-off valves are suitable for use with Amerex Kitchen Fire Suppression Fire Suppression system. These valves, when used in conjunction with P/N 12740 Gas Trip Assembly, perform the same functions as Amerex’s gas shut-off valves. The part numbers of the valves acceptable for this use are listed below. They are intended to be installed using the same installation instruction as Amerex’s gas shut-off valves; see Installing a Mechanical Gas Valve in the installation section for instruction on installation.

NOTE: P/N 12740 gas trip assembly must be purchased separately.

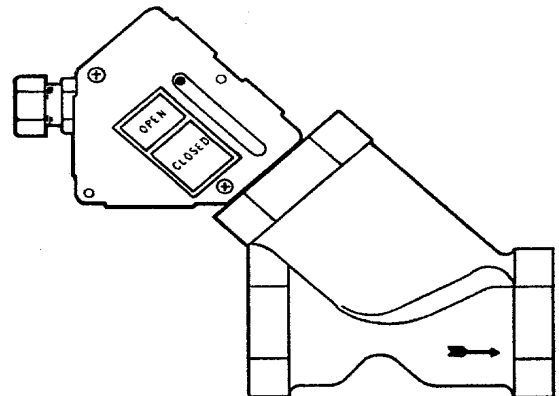

APPLICATIONS		
Ansul Part No.	Size	Max. Operating Pressure
55598	3/4"	10 PSI (69 kPa)
55601	1"	
55604	1 1/4"	
55607	1 1/2"	
55610	2"	

SNAP ACTION SWITCH (P/N 12524)

Snap Action Switch, designed to be mounted in the MRM / MRM II / PRM, are used to control various output functions. These output functions may involve turning off or turning on power. Examples of output functions are sounding a visual or audible alarm, operate an electrical gas valve, send a signal to an unsupervised building fire alarm system, shut off supply air fans and energize a relay to shut off electrical appliances. Two SPDT snap action switches, one PN12524 and one PN 18312, are pre-installed in the MRM, MRM II and PRM. Up to 2 additional SPDT switches may be added for a total of our configurations – SPDT, DPDT, 3PDT and 4PDT.

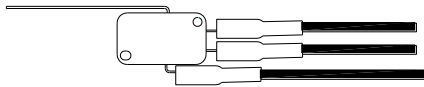

SNAP ACTION SWITCH
 SINGLE POLE
 DOUBLE THROW
 P/N 12524

Red	Common	Non Alarm Condition
Yellow	N.O.	
Black	N.C.	

ALARM-INITIATING SNAP ACTION SWITCH (P/N 18312)

One alarm initiating Snap Action Switch, (P/N 18312), is pre-installed and is used when the system is required to be electrically connected to a fire alarm system per NFPA 17 and NFPA 72 in a supervised, four-wire manner. It is designed to be mounted in the Mechanical Release Module (MRM / MRM II) and the Pneumatic Release Module (PRM) only for the purpose of initiating an alarm in a supervised fire alarm system. All Snap Action Switch connections are to be made outside the MRM / MRM II / PRM in an approved junction box. This is a SPST; 0.25A; 30 VDC; N.O. switch.

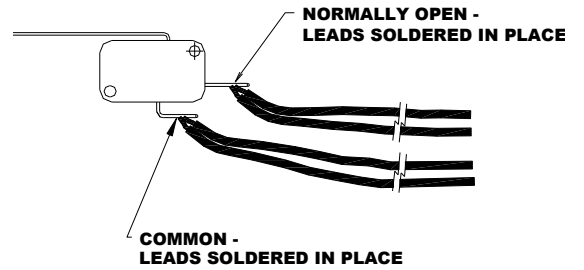

VENT PLUG (P/N 10173)

The vent plug is required in the system actuation network to allow a means of relieving pressure in the actuation piping after a system discharge, and to prevent a slow build-up of pressure in the actuation line.

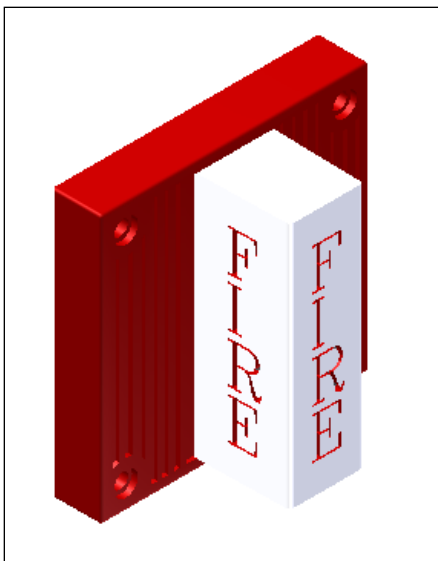

120 VAC Horn & Strobe (P/N 21396)

The Horn & Strobe Assembly is provided for use when visual and sound warnings are required at system actuation. The unit requires the use of a 4" square (10.16cm sq.) x 2 1/8" (5.5cm) deep back-box with 1/2" conduit entrance on the top of the box. This device is to be used with 120 VAC power supply and may be used inside or outside. Refer to installation and setup instructions supplied with each unit.

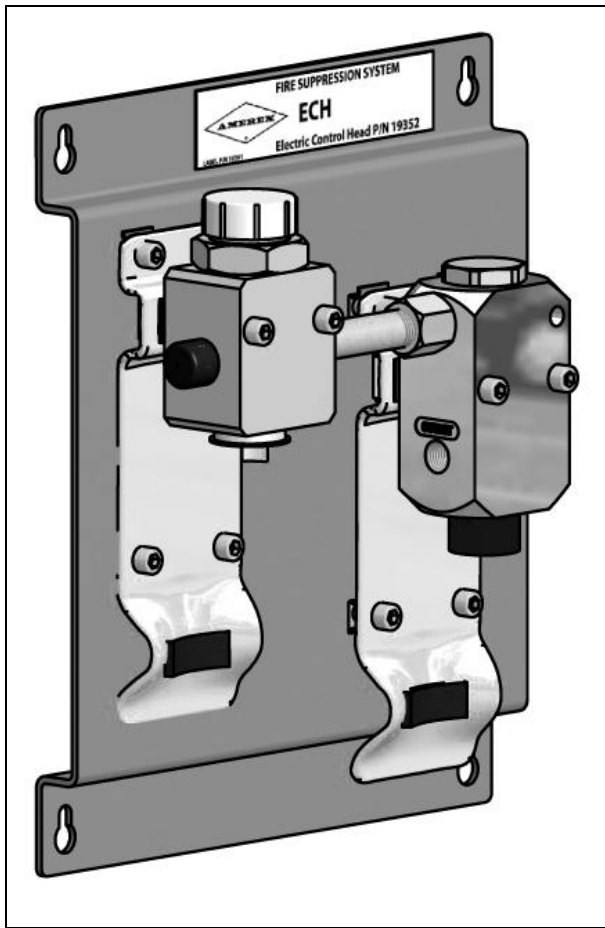
**ELECTRICAL CONTROL HEAD (ECH) P/N 19352**

The ECH is to be used in cases where electrical detection is desired or required, due to physical hazard size or other design considerations. This control head replaces the ERM which has been discontinued. Other components that are necessary to complete an installation with the ECH are as follows (but not limited to):

P/N 19347 Nitrogen Actuation Cylinder
P/N 09956 15 in³ Nitrogen Cylinder
P/N 17014 Electric Actuator
P/N 19340 Releasing Panel, SR-X
P/N 17001 Manual Actuation Button (optional)
P/N 17839 Cap Electric Actuator (optional)

An installed ECH has the capability of pneumatically firing up to ten (10) Amerex Restaurant Agent Cylinder Assemblies. Manual actuation can be accomplished with the optional P/N 17001 Manual Actuation Button installed on top of the P/N 17014 Electric Actuator, and/or with Amerex Electric Pull Station(s) connected to the Amerex SR-X Releasing Panel.

See the relevant sections of this manual for design, installation and servicing requirements. The ECH is intended for indoor use, only. Two stainless steel band clamps (not shown) are included with the ECH assembly for securing the two nitrogen cylinders to their brackets. The ECH is not supplied with an outer enclosure.

KITCHEN HOOD FASTENER

Amerex is pleased to offer two methods of fastening hardware to the underside of the hood without having access to the top of the hood. Simply drill a 25/64" Dia. hole and install the listed fastener, for use with stainless steel hood material 0.027" to 0.165" thick.

RIVET TYPE STUD (P/N 20535)

The rivet type stud is a 1/4 - 20UN – 2A threaded stud with approximately 3/4" of length. This device may be used for mounting detector brackets, conduit fasteners, PRM clips, pipe hangers, etc. Attach devices to the stud using a standard 1/4-20UN nut and lock washer. Rivet studs come 10 to a bag.

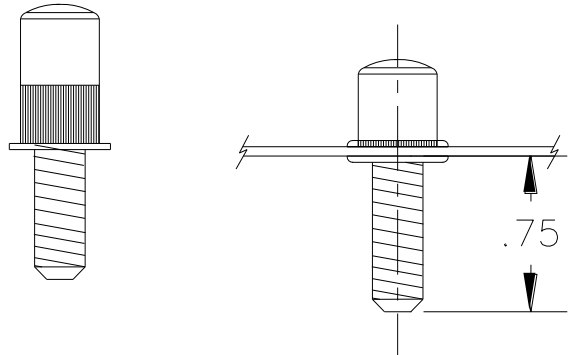

INSTALLED

RIVET TYPE NUT (P/N 20536)

The rivet type nut is tapped 1/4 - 20UN – 2B with approximately 3/4" of length. This device may be used for mounting detector brackets, conduit fasteners, PRM clips, pipe hangers, etc. Attach devices to the tapped blind rivet using a standard 1/4-20UN bolt or screw and lock washer. Rivet nuts come 10 to a bag.

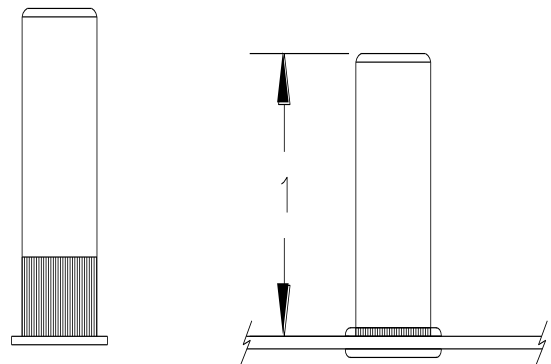

INSTALLED

RIVET INSTALLATION TOOL SET (P/N 20552)

The Rivet Installation Tool Set Comes complete with mandrel and nosepiece for installing both studs and nuts. Instructions on set up and use of the tool are contained in the box with each tool.

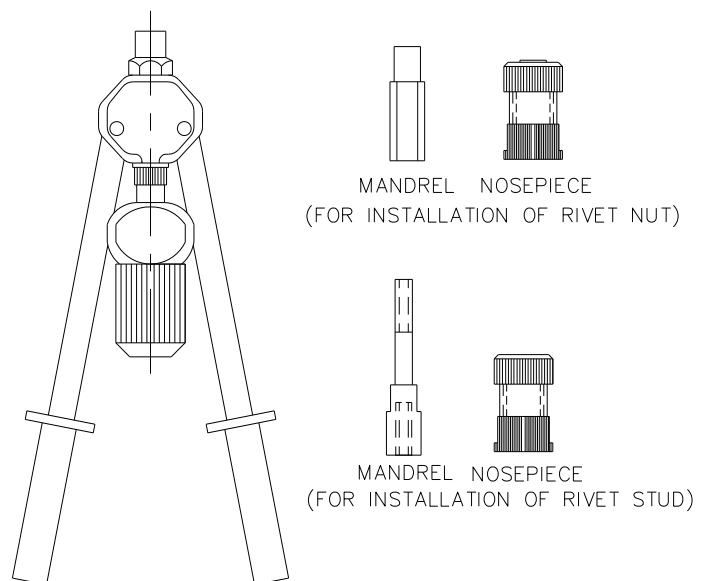

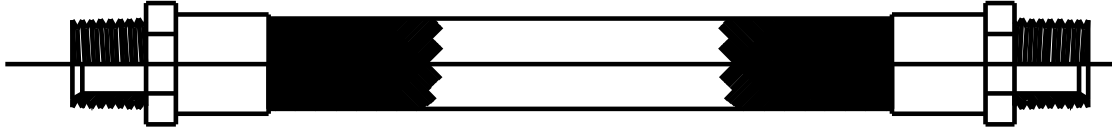
FLEXIBLE HOSE - HAZARD AREA (PN20473)

This hose is designed to be used when a flexible movement of the nozzle branch line is desired. Such as when an appliance needs to be moved for cleaning and the nozzle protecting the appliance is fixed to the appliance. Hose length is 48" end to end and is supplied with ½" NPT ends. The flex hose is limited to use on the appliance branch line only and cannot be used on supply line or supply branch line.

The flexible hose is to be connected to the Nozzle Branch line in a manner to prevent kinking or collapsing of the hose. It is to be used to provide for movement of the appliance without the appliance protection being disconnected from the fire suppression system.

The flex hose has a minimum bend radius of 7". The piping limitations for Nozzle Branches do not change when flexible hose is used in the line. However, the flex hose takes the place of 4 feet of pipe.

A maximum of three flex hoses may be used on an agent cylinder piping network.

An appliance locating device is to be used to insure that the appliance is placed back in proper alignment after being moved for cleaning.

NO RESTRAINT CABLE IS REQUIRED

SECTION 3

DESIGN

MANUAL P/N 20150

AMEREX RESTAURANT FIRE SUPPRESSION SYSTEM

**Tested and Listed by
Underwriters Laboratories, Inc.
to UL Standard 300
EX 4658**

**Tested and Listed by
Underwriters Laboratories of Canada
To ULC/ORD 1254.6-1995**

December 2008

DUCT PROTECTION

NOTE: An Amerex KP & ZD Kitchen Fire Suppression System have the same listed criteria for the protection of the Duct and Plenum.

DUCT PROTECTION LIMITATIONS SINGLE NOZZLE (P/N 16416)

The Amerex Duct Nozzle (P/N 16416) is listed to protect restaurant cooking ducts of unlimited length up to 50 perimeter inches (127 cm) or 16 diameter inches (40.6 cm) using one nozzle. The nozzle has one flow point and must be centered within the duct, placed 2 – 8 inches (5.08 – 20.32 cm) into the duct opening and aimed at the center of the cross section of the duct.

NOTE: In no case shall the diagonal dimension of the duct exceed 18.8 inches without additional duct nozzles.

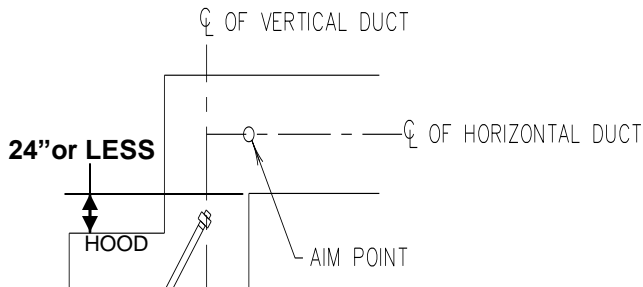

**Vertical / Horizontal Transition
with a rise of 24" or less.**

Special Note: For ducts with short vertical/horizontal transitions reference the diagram above with respect to nozzle aim.

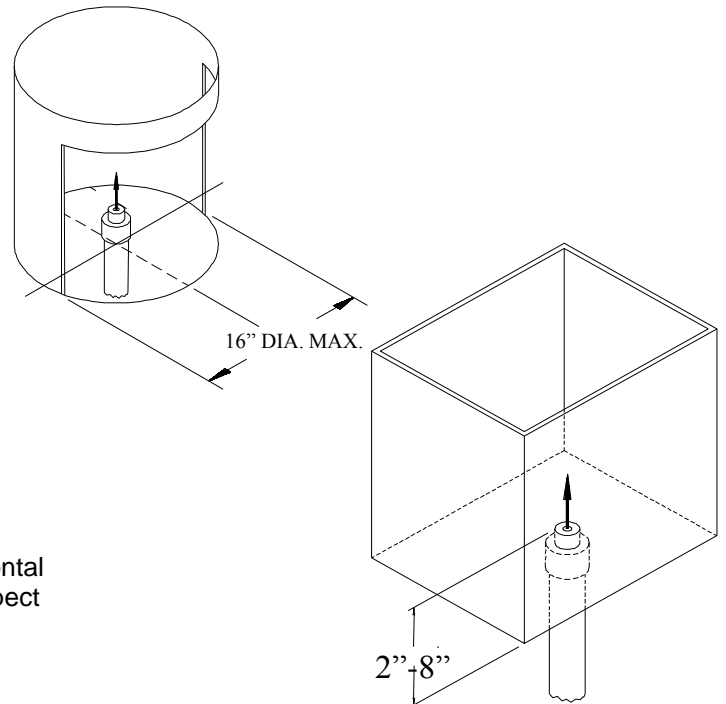

TRANSITION LIMITATIONS – SINGLE NOZZLE (P/N 16416)

A transition is a section found on some exhaust systems between the hood and the duct. One Amerex duct nozzle (P/N 16416) will protect a transition at the point where the transition is 50 perimeter inches (127 cm) or less or a diameter of 16 inches (40.6 cm) or less. The nozzle has one flow point and must be placed in the center of the opening at the point where the perimeter inches are 50 (127 cm) or less or where the diameter inches are 16 (40.6 cm) or less and aimed at the center of the cross section on the duct. Additional duct protection is not required when using this method.

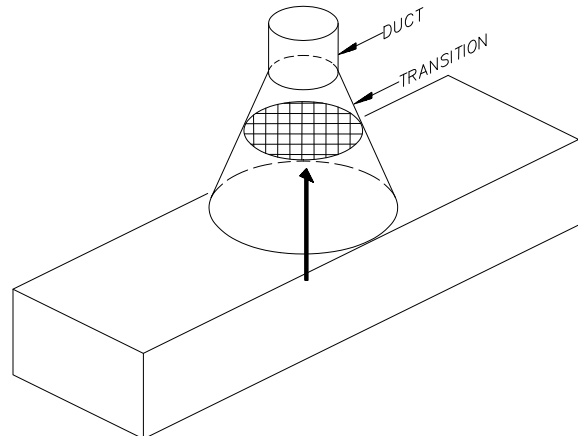
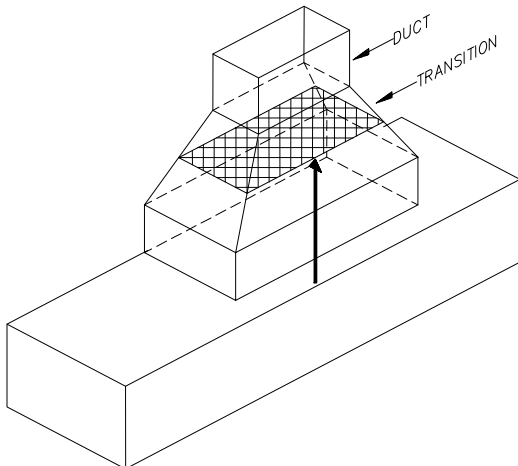

DUCT PROTECTION LIMITATIONS – TWO NOZZLES (2 x P/N 16416)

Two Amerex Duct Nozzles (P/N 16416) will protect ducts with a perimeter of 51 inches to 84 inches (129.5 – 208.3 cm) or a maximum diameter of 26 inches (66 cm). To correctly position the nozzles in a rectangular duct divide the duct along its longest side into four equal distances. A circular duct should be divided along a centerline into four equal distances. A nozzle should be placed at one quarter of the duct's width (or diameter) with both nozzles on the centerline, paced 2-8 inches (5.08 - 20.3 cm) into the duct opening and aimed at the center of the modular cross section of the duct. Each nozzle has one flow point.

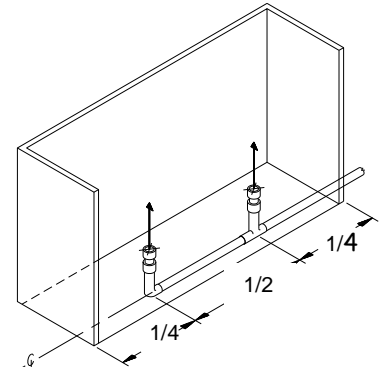

NOTE: In no case can the diagonal dimension of each **module** exceed 18.8 inches (46 cm).

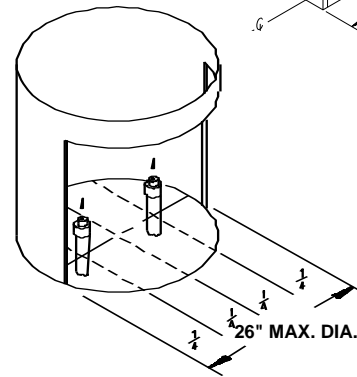
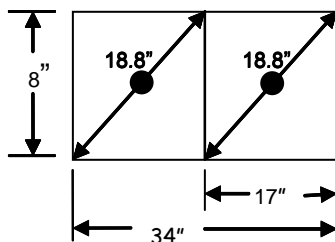

DUCT PROTECTION LIMITATIONS – MULTIPLE NOZZLES (P/N 16416)

Protecting ducts larger than 84 perimeter inches (208.3 cm) utilizing the single flow point nozzle (P/N 16416). Divided the perimeter by 42 (104 cm) and round up to the next whole number. Divide the duct cross section into the same number of equally sized modules. Check the modules to insure they are equal to or less than 50 perimeter inches and have a diagonal equal to or less than 18.8 inches. If they meet the criteria then place a duct nozzle in the center of each module, 2"-8" into the hood/duct opening.

DUCT PROTECTION LIMITATIONS 100 IN. PERIMETER TWO – 1½ FLOW POINT NOZZLES (P/N 11983)

The Amerex Solid Fuel Appliance/Duct Nozzle (P/N 11983) is listed to protect a restaurant cooking exhaust duct of unlimited length, unlimited changes in direction and up to 100 perimeter inches (254 cm) or 32 inch diameter (81.2 cm) using two nozzles. The nozzles total three flow points and to properly position the nozzles, a rectangular duct should be divided along its longest side into four equal distances. A circular duct should be divided along its center line into four equal distances. The nozzles are to be placed at one quarter and three quarters position of the duct width (or diameter) with both nozzles on the center line, placed 2 - 8 inches (5.08 – 20.3 cm) into the duct opening and aimed straight up in a vertically run duct.

NOTE: In no case can the diagonal dimension of the duct exceed 37.2 inches (94.4 cm) without adding additional duct nozzles.

NOTE: The use of one Duct Nozzle P/N 11983 is permitted for duct 50 perimeter inches or less in the same manner as Duct Nozzle 16416.

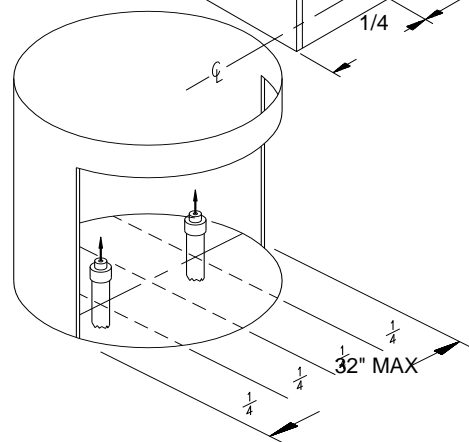
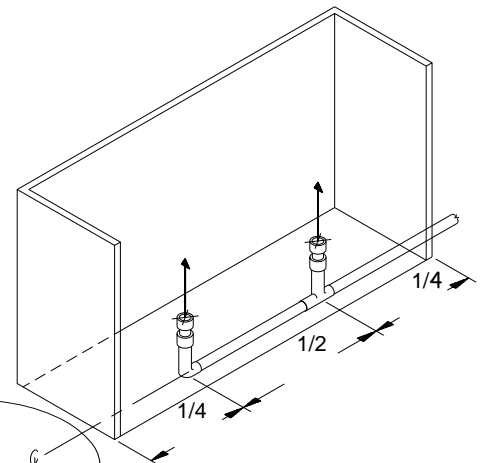

DUCT PROTECTION LIMITATIONS 150 IN. PERIMETER THREE 1½ FLOW POINT NOZZLES (3 x P/N 11983)

The Amerex Solid Fuel Appliance/Duct Nozzle (P/N 11983) is listed to protect restaurant cooking exhaust ducts of unlimited length, unlimited changes in direction and up to 150 perimeter inches (381 cm) or 48 diameter inches (122 cm) using three nozzles. The nozzles total four and one-half flow points and to properly position the nozzles, a rectangular duct should be divided along its longest side into six equal distances. A circular duct should be divided along its center line into six equal distances. The nozzles are to be placed at one sixth, one half and five sixths positions of the duct width (or diameter) on the center line, placed 2-8 inches (5.08 – 20.3 cm) into the duct opening and aimed straight up for vertically run duct.

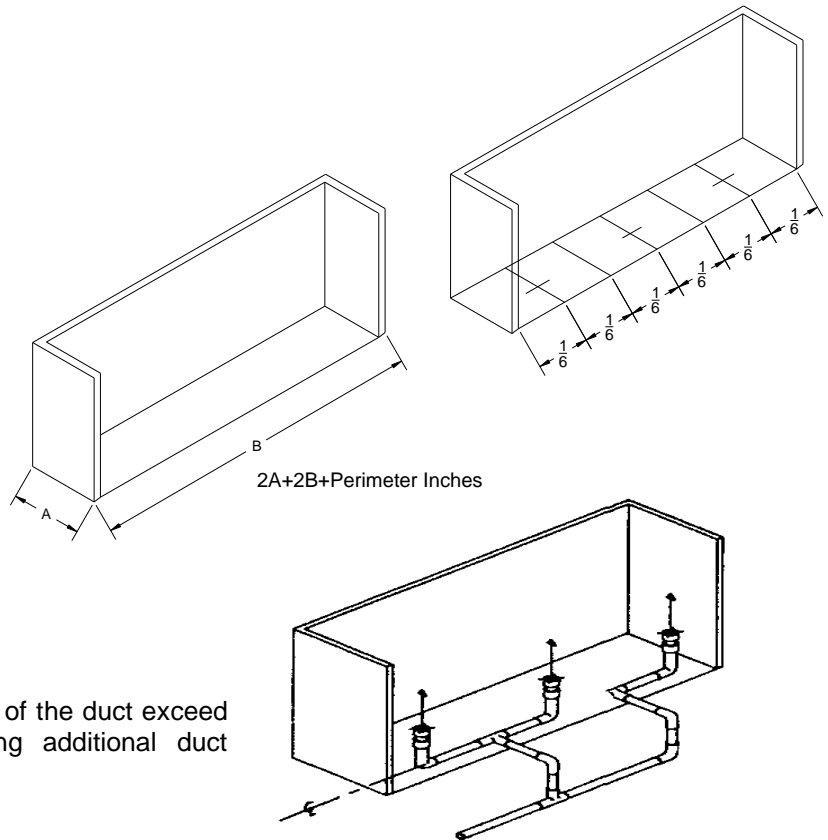

NOTE: In no case can the diagonal dimension of the duct exceed 55.9 inches (142 cm) without adding additional duct nozzles.

TRANSITION LIMITATIONS – TWO NOZZLES (P/N 11983)

A transition is a section of some exhaust systems between the hood and the duct. Two Amerex solid fuel appliance/duct nozzles (P/N 11983) will protect a transition at the point where the transition is 100 perimeter inches (254 cm) or less or a diameter of 32 inches (94.4 cm) or less. The nozzles total three flow points and to properly position the nozzles, a rectangular duct should be divided along its longest side into four equal distances. A circular duct should be divided along its center line into four equal distances. The nozzles are to be placed at one quarter and three quarters position of the duct width (or diameter) with both nozzles on the center line, placed 2 - 8 inches (5.08 – 20.3 cm) into the duct opening and aimed straight up in a vertically run duct. Additional duct protection is not required when using this method.

NOTE: In no case can the diagonal dimension of the duct exceed 37.2 inches (94.4 cm) without adding additional duct nozzles.

(REFER TO PAGE 3-1 FOR PICTORIAL REPRESENTATION)

NOZZLE LOCATION AND AIMING FOR SHORT VERTICAL/ HORIZONTALLY TRANSITION RUN DUCTS PROTECTED BY DUCT NOZZLE 11983

The nozzles are to be located on the centerline of the vertically run duct, 2-8 inches (5.08-20.3cm) into the hood/duct opening. The aiming point is to be a point 3 (7.6cm) inches above the base of the horizontally run duct and in the same vertical plane of the nozzle. See illustration.

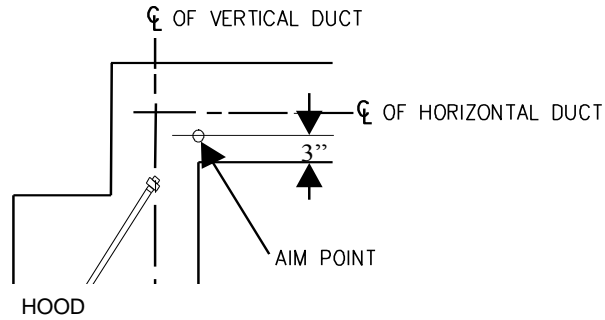

Vertical / Horizontal Transition with a rise of 24" or less.

DUCT PROTECTION – MODULAR APPLICATION OF MULTIPLE NOZZLES LISTING (P/N 11983)

Protecting ducts larger than the perimeter listed for a multiple nozzle coverage is a simple process. The following example shows how the listing for duct protecting a duct with a perimeter of 100 inches using two nozzles PN 11983 is applied to a duct with a perimeter larger than 100" but less than 166". We must first divide the cross sectional area of the duct into modules with a perimeter equal to or less than 100". Check the modules to insure they have a diagonal equal to or less than 37.2 inches. If all criteria is met, space the duct nozzles in each module in compliance with the multiple nozzle coverage listing and 2"-8" into the hood/duct opening.

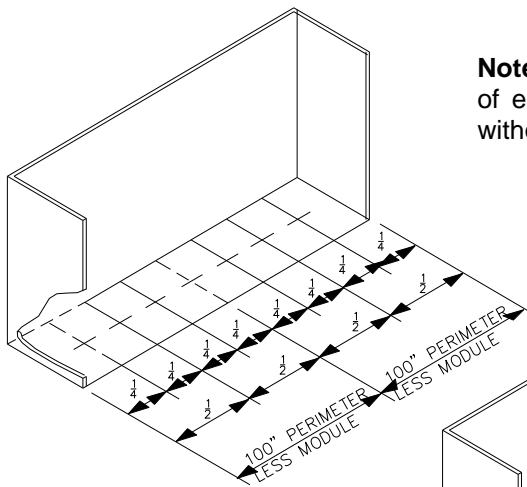

Note: In no case can the diagonal dimension of each module exceed 37.2 inches (94.4 cm) without adding additional duct nozzles.

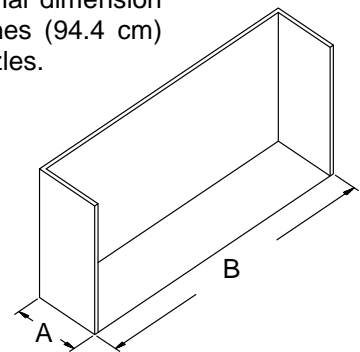
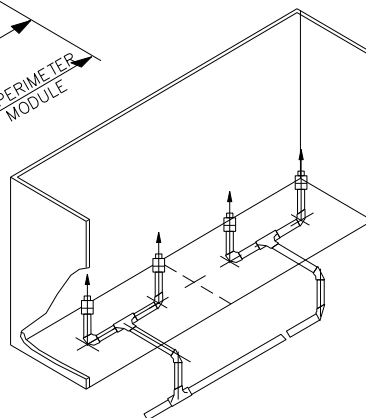

$$2A + 2B = \text{PERIMETER}$$

OR

$$(A + B) 2 = \text{PERIMETER}$$

PLENUM PROTECTION

NOTE: An Amerex KP & ZD Kitchen Fire Suppression System have the same listed criteria for the protection of the Duct and Plenum.

PLENUM PROTECTION LIMITATIONS – SINGLE FLOW POINT NOZZLE (P/N 11982)

The Amerex Appliance, Plenum Nozzle (P/N 11982) is capable of protecting plenums up to 10 feet (3.048m) long with either a single inclined filter bank or a “V” bank filter arrangement. The filter height cannot exceed 24 inches (60.96 cm). Each plenum nozzle uses one flow point. The nozzle must be positioned 4 inches (10.16) maximum from the end wall of the hood, aimed horizontally and positioned down 1/3 the vertical filter height from the top of the filter. The width of a “V” bank filter arrangement is limited to a maximum of 48” (122 cm).

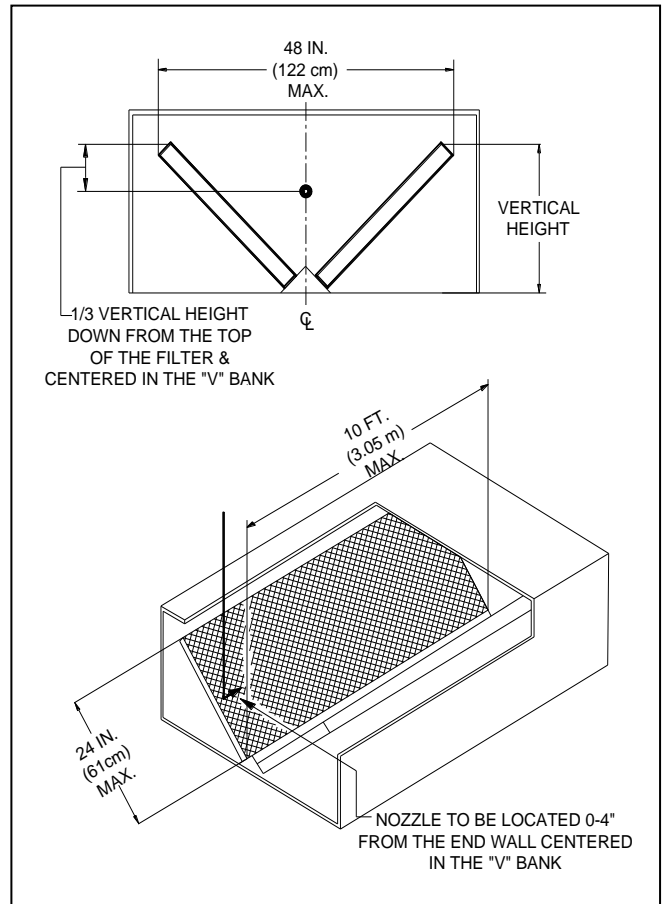
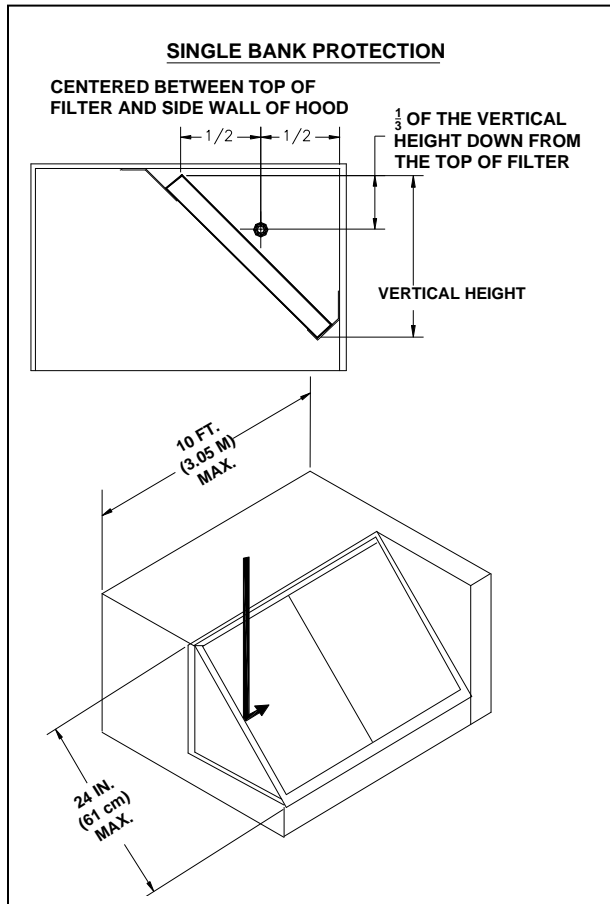

PLENUM PROTECTION – MULTIPLE NOZZLES

Plenums exceeding 10 feet (3.048 m) in length may be protected by using multiple plenum nozzles. Each nozzle must be protecting an area of no more than 10 feet in length. Nozzles may be positioned facing each other or facing the same direction as long as the entire plenum area is being covered. Nozzles may not face in opposite directions from a common tee.

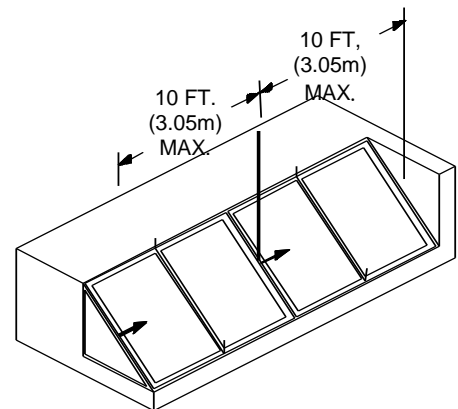
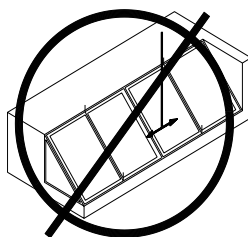

KP APPLIANCE PROTECTION

NOTE: The Amerex ZD Kitchen Fire Suppression System utilizes the same listed KP appliance protection criteria for "Dedicated Appliance Protection".

FRYER PROTECTION (FULL VAT)

TWO FLOW POINT NOZZLE (P/N 13729)

MAXIMUM AREA: 19½ in. (50 cm) x 25-3/8 in. (65 cm) including drainboard interface area
19½ in. (50 cm) x 19 in. (48 cm) not including drainboard interface area

The Amerex Fryer Nozzle (P/N 13729) uses two flow points and will protect a full vat fryer. If the fryer does not include a drainboard, the maximum fryer dimensions for single nozzle coverage are 19" x 19½" (48 x 50 cm) and the maximum protected area is 2.53 ft² (2350 cm²). If the fryer does contain a drainboard the maximum fryer dimensions for single nozzle coverage is 25-3/8" x 19½" (65 x 48 cm) and the maximum protected area is 3.44 ft² (3195 cm²). However, the maximum hazard area must not exceed 19" x 19½" (48 x 50 cm). The nozzle must be located along or anywhere within the protected area. Nozzle heights must be within 36 to 48 inches (91.44 – 121.92 cm) above the appliance surface and aimed to the center of the hazard area of the appliance.

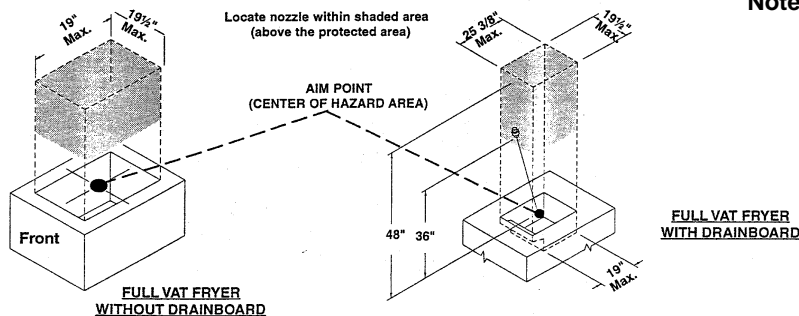
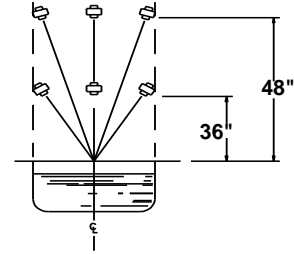

Note: Maximum & minimum heights must be measured vertically from the tip of nozzle to the top of the appliance.

LOW PROXIMITY APPLICATION FRYER PROTECTION (FULL VAT)

TWO (2) SINGLE FLOW POINT NOZZLE (P/N 11982)

MAXIMUM AREA: 19½ in. (50 cm) X 25 3/8 in. (65 cm) (including drainboard interface area)
19½ in. (50 cm) x 19 in. (48 cm) (not including drainboard interface area)

A pair of Amerex single flow point nozzles (P/N 11982) will protect a full vat fryer. The nozzles must be used in pairs located on the perimeter of the appliance, ½" back from the inside edge of the appliance and within a zone extending 6" in both directions of the center of the hazard. The nozzles are to be located 180° apart (directly across from one another). They are to be aimed at a point 3" below the top of the appliance and directly below the opposing nozzle. If the fryer does not include a drainboard, the maximum fryer dimensions are 19½" x 19" (50 x 48 cm) and the maximum protected area is 2.53 ft² (2530 cm²). If the fryer does contain a drainboard, the maximum fryer dimensions are 25 3/8" x 19½" (65 x 50 cm) and the maximum protected area is 3.44 ft² (3195 cm²). However, the maximum hazard area must not exceed 19½" x 19" (50 x 48 cm). The nozzle's height must be within 17½" to 36" (45 - 92 cm) above the appliance surface.

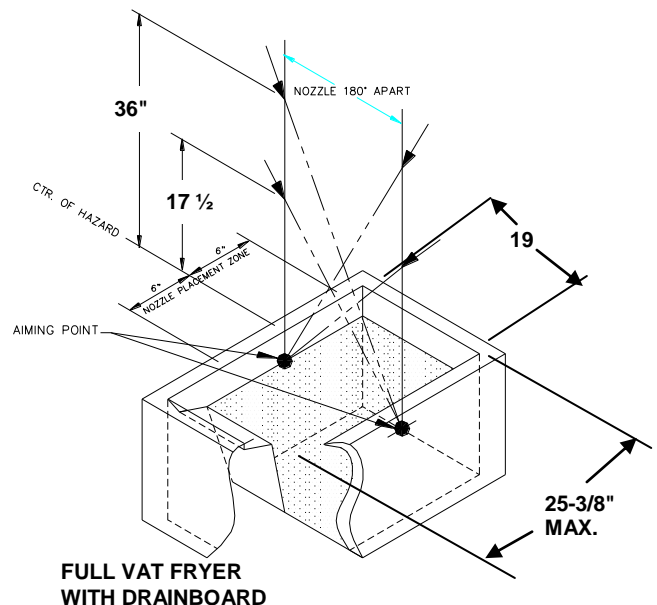

FRYER PROTECTION (FULL VAT W/ 1" DRIP BOARD)
ONE – TWO FLOW POINT NOZZLE (P/N 13729)
MAXIMUM AREA: 624 sq. in. (4025.8 sq. cm) of FRY POT

The Amerex Nozzle (P/N 13729) is two flow points and will protect a full vat fryer having an area of 624 sq. in. and a longest side of 26 inches without a drip board. The nozzle must be located anywhere over the protected area and aimed at the center of the hazard. Nozzle heights must be within 36 to 50 inches (91.4 – 127 cm) above the appliance surface.

The example below illustrates how the fryer listing above can be applied to a Tilting Skillet / Brazing Pan.

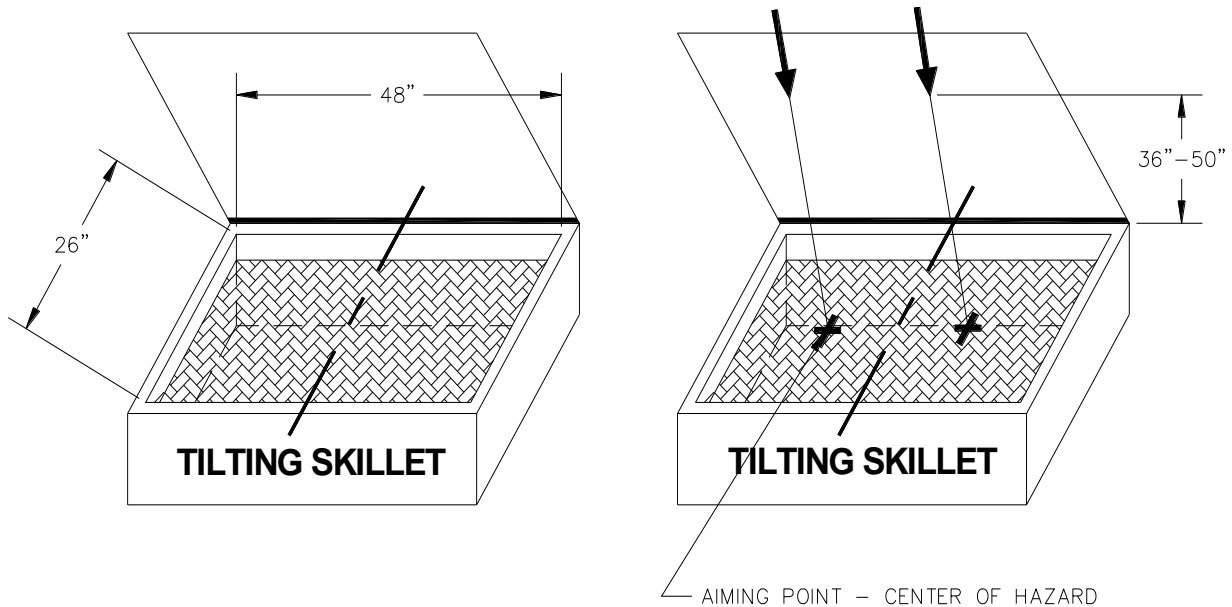

FIGURE 1

FIGURE 2

Figure 1 is an illustration of a large tilting skillet measuring 26" x 48" and the tilting skillet has no drip board. We calculate the cooking area of the tilting skillet by multiplying the width X length and the result is 1248 sq. in. We now divide the area by the listed area of 624 and the resultant is 2. Therefore, two nozzles are required to protect this appliance. (If the resultant had been greater than 2, we would have rounded up to 3.

Figure 2 shows how the hazard was divided into two equal modules 26" x 24" and each module has an area of 624 sq. in. Therefore, the use of two nozzles P/N13729 will protect this hazard. When protecting a tilting skillet with a cover or lid the nozzles must be placed to the front edge of the appliance and aimed to the center of the module.

The same process is to be used to apply this listing to a large fryer except the fryer must fall within the required maximum fryer size of six square feet.

**FRYER PROTECTION (SPLIT VAT)
TWO FLOW POINT NOZZLE (P/N 13729)**

**MAXIMUM AREA: 14 in. (35.5 cm) X 21 in. (53.5 cm) (including drainboard interface area)
14 in. (35.5 cm) x 15 in. (38.1 cm) (not including drainboard interface area)**

The Amerex fryer nozzle (P/N 13729) uses two flow points and will protect a split vat fryer. If the fryer does not include a drainboard, the maximum fryer dimensions for single nozzle coverage are 15" x 14" (38.1 x 35.5 cm) and the maximum protected area is 1.46 ft² (1356 cm²). If the fryer does contain a drainboard, the maximum fryer dimensions for single nozzle coverages are 21" x 14" (53.5 x 35.6 cm) and the maximum protected area is 2.0422 (1897 cm²). However, the maximum hazard area must not exceed 15" x 14" (38.1 x 35.5 cm). The nozzle must be located within the protected area on a line perpendicular to the longest side of the fryer passing through the center of the hazard area. Nozzle heights must be within 40 to 50 inches (101.6 – 127 cm) above the appliance surface and aimed to the center of the hazard area of the appliance.

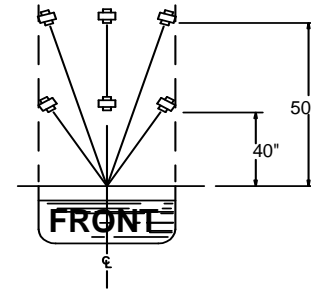

SPLIT VAT FRYER WITH DRAINBOARD

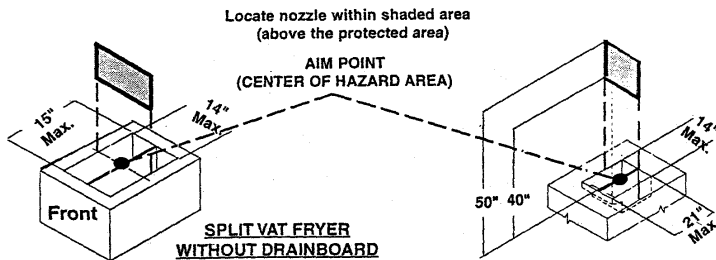

NOTE: Maximum and minimum heights must be measured vertically from the tip of nozzle to the top of the appliance.

SPLIT VAT FRYER WITH DRAINBOARD

FRYERS EXCEEDING SINGLE NOZZLE PROTECTION:

Multiple Amerex fryer nozzles (P/N 13729) may be used to protect single vat fryers with maximum protected areas exceeding single vat coverages up to a maximum protected area of 6 ft.². The fryer must be divided into modules for single nozzle coverages and the nozzle located and aimed for each module as indicated for single nozzle coverages. For modules that do not include drainboards, the maximum module dimensions for single nozzle coverages is 19 1/2" x 19" (50 x 48 cm) and the maximum protected area is 2.53 ft² (2350 cm²). If the module does contain a drainboard, the maximum module dimensions for single nozzle coverage is 25 3/8" x 19 1/2" (65 x 50 cm) and a maximum protected area is 3.44 ft² (3195 cm²). However, the maximum frying area of a module must not exceed 19 1/2" x 19" (50 x 48 cm).

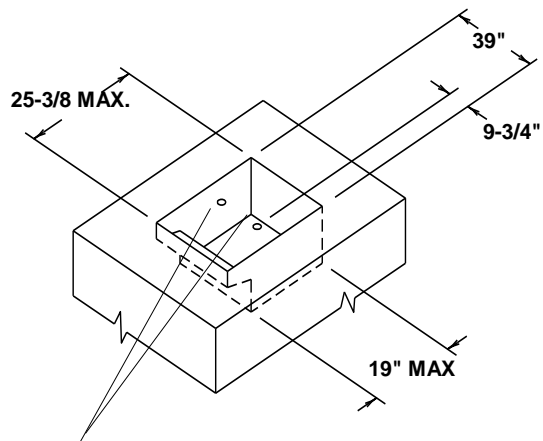

AIM POINTS

**SINGLE BURNER RANGE PROTECTION
ONE – ½ FLOW POINT NOZZLE (P/N 11984)**

The Amerex half (½) flow point nozzle (P/N 11984) will protect a single burner with a surface area of 18" x 18" (46 x 46 cm). The nozzles must be located on the perimeter of the burner and 20 to 24" (51 – 61 cm) above the burners surface. The nozzle is aimed at a point 7" above the center of the burner.

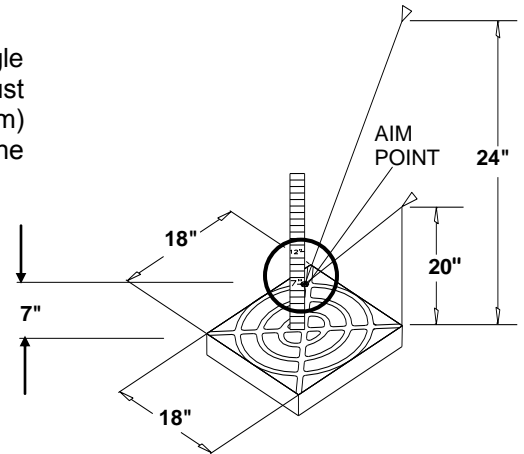

**SINGLE BURNER RANGE PROTECTION – OVERHEAD
ONE – ½ FLOW POINT NOZZLE (P/N 11984)**

The Amerex half (½) flow point nozzle (P/N 11984) will protect a single burner with a surface area of 18" x 18" (46 x 46 cm). The nozzles must be located directly above the center of the burner and 24 to 42" (61 - 107 cm) above the burners surface. The nozzle is aimed at the center of the burner.

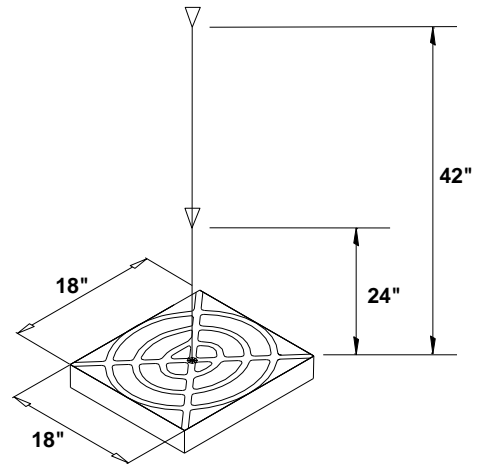

**TWO BURNER RANGE PROTECTION –
SINGLE FLOW POINT NOZZLE (P/N 11982)**

The Amerex appliance, plenum nozzle (P/N 11982) has one flow point and will protect a range surface area of 14" x 28" (36 x 71 cm). The center to center distance between burners must not exceed 14" (36 cm). The nozzle must be located 44 - 48" (112 - 122 cm) above the range surface and centered between the two burners. The range surface area is measured from the outside of the burner to the outside of the burner.

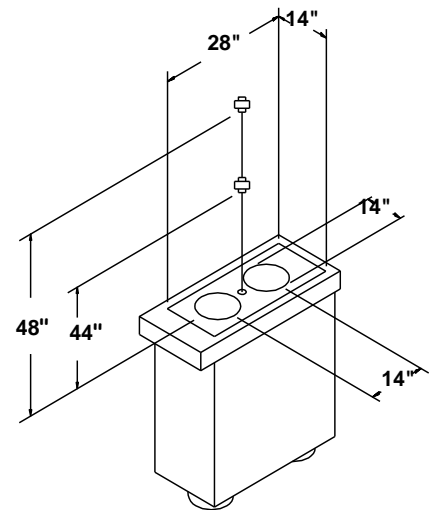

NOTE: Maximum and minimum heights must be measured from the tip of nozzle to the surface of the appliance.

RANGE PROTECTION SINGLE FLOW POINT NOZZLE (P/N 11982)

The Amerex appliance plenum nozzle (P/N 11982) has one flow point and will protect a range surface area of 12" x 24" (31 x 61 cm). The center to center distance between burners must not exceed 12" (31 cm). The nozzle must be located 36 – 50" (91 - 127 cm) above the range surface and centered between the two burners. The range surface area is measured from the outside of the burner to the outside of the burner.

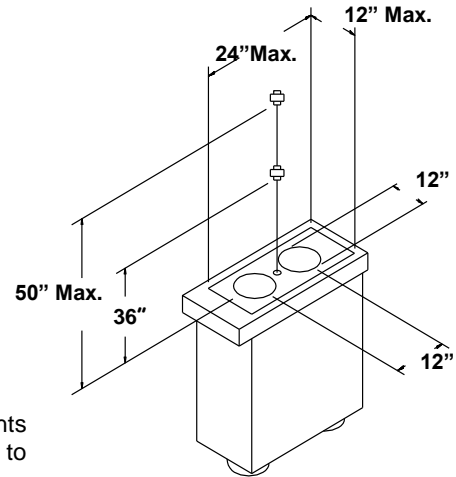

Note: Maximum & minimum heights must be measured from the tip of nozzle to the surface of the appliance.

RANGE PROTECTION MULTIPLE NOZZLES (P/N 11982)

For ranges that have a surface area exceeding the capabilities of a single appliance nozzle, multiple nozzles must be used provided that the surface area of the range is divided into equally sized modules. Each module must be equal to or less than 12" x 24" (31 x 61 cm).

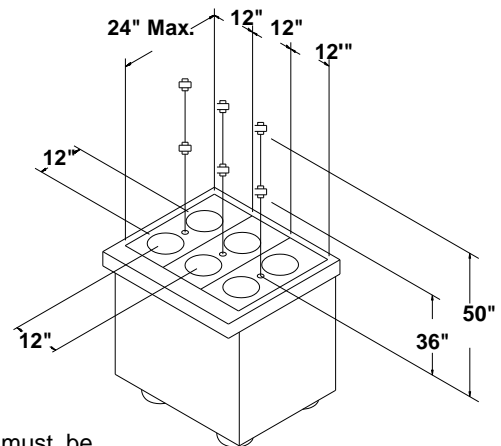

Note: Maximum & minimum heights must be measured from the tip of nozzle to the surface of the appliance.

**RANGE PROTECTION
TWO - HALF FLOW POINT NOZZLE (P/N 11984)**

The Amerex appliance nozzle (P/N 11984) has one-half flow point value and when used as a pair as illustrated below will protect a range surface area of 12" x 36" (31 x 92 cm). The nozzle must be located 20 – 30" (50.8 – 76.2 cm) above the range surface, on the burner centerline, 2 inches (5 cm) outboard of the burner and aimed at the center of the hazard area. The nozzles are to be at the same height and on opposite sides of the range hazard area.

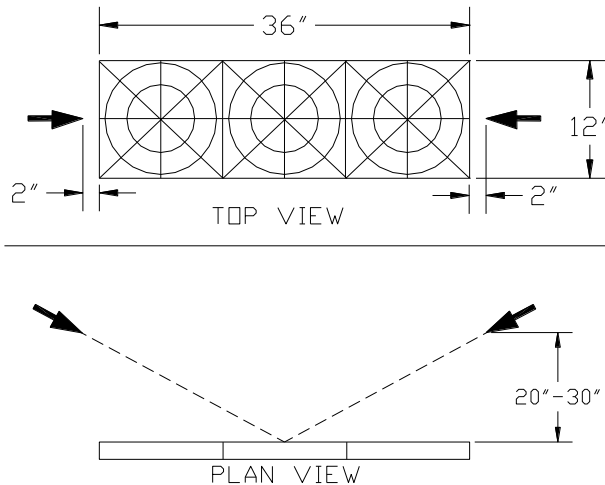

Note: Maximum & minimum heights must be measured from the tip of nozzle to the surface of the appliance.

**RANGE PLUS BACK-SHELF PROTECTION
OVERHEAD APPLIANCE NOZZLE (P/N 11982)**

The Amerex appliance nozzle (P/N 11982) has a one flow point value and will protect a range burner area of 12" x 24" (31 X 61 cm) from an overhead position. The back shelf must be at least 20" high (51 cm) and must not cover more than 11" (28 cm) of the back burners. The nozzle must be located 40 – 47" (102 – 119 cm) above the range surface, on the burner centerline, 4-6 inches (10 – 15 cm) forward of the center of the two burners and aimed at the center of the hazard area.

Note: Maximum & minimum heights must be measured from the tip of nozzle to the surface of the appliance.

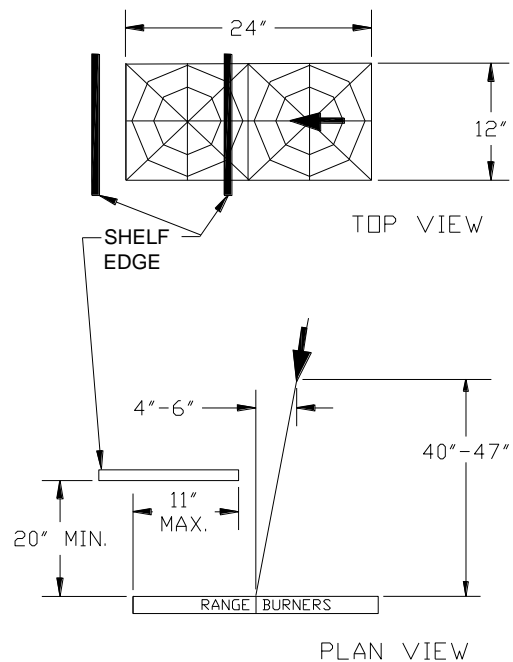

**FOUR (4) BURNER RANGE PROTECTION
TWO (2) FLOW POINT NOZZLE (P/N 14178)**

The Amerex 4 burner range nozzle (P/N 14178) has two (2) flow points and will protect a range surface area of 24" x 24" (61 x 61 cm). The center to center distance between burners must not exceed 12 inches. The nozzle must be located 18 – 50" (46 – 127 cm) above the range surface and centered between the burners. The nozzle is aimed straight down at the center of the appliance.

NOTE: Maximum and minimum heights must be measured from the tip of nozzle to the surface of the appliance.

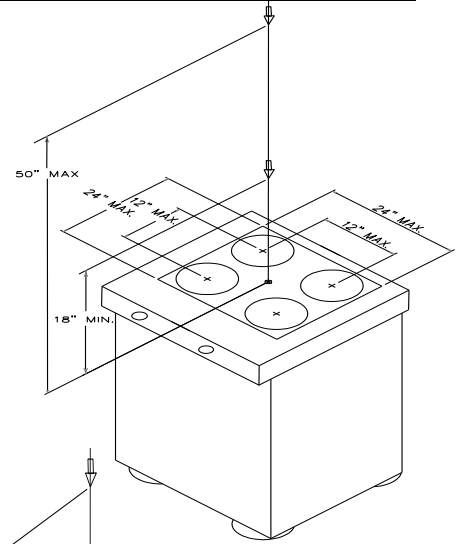

**RANGE PROTECTION -
MULTIPLE NOZZLES (P/N 14178)**

For ranges that have a surface area exceeding the capabilities of a single nozzle, multiple nozzles must be used provided that the surface area of the range is divided into equally sized modules. Each module must be equal to or less than 24" x 24" (61 x 61 cm).

NOTE: When using this nozzle to protect a two (2) burner range the aiming point is where an 8.50" radius from the center of each burner crosses one another

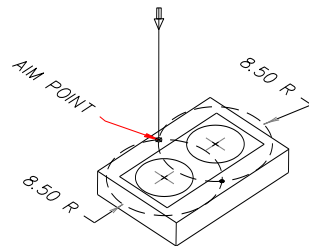
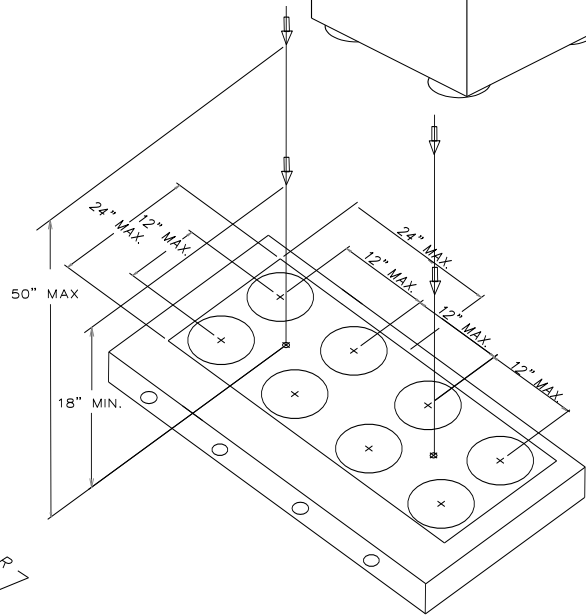

**WOK PROTECTION -
SINGLE FLOW POINT NOZZLE (P/N 11982)**

The Amerex appliance plenum nozzle (P/N 11982) has one flow point and will protect a wok with dimensions between a minimum diameter of 14" (36 cm) and a maximum diameter of 24" (61 cm) inclusive. The wok must have a height dimension between a minimum of 4" (10 cm) and a maximum of 7" (18 cm) inclusive. The nozzle must be centered over the center of the wok and located at a height between 40" (102 cm) and 50" (127 cm) from the bottom of the inside of the wok and aimed at the center of the wok.

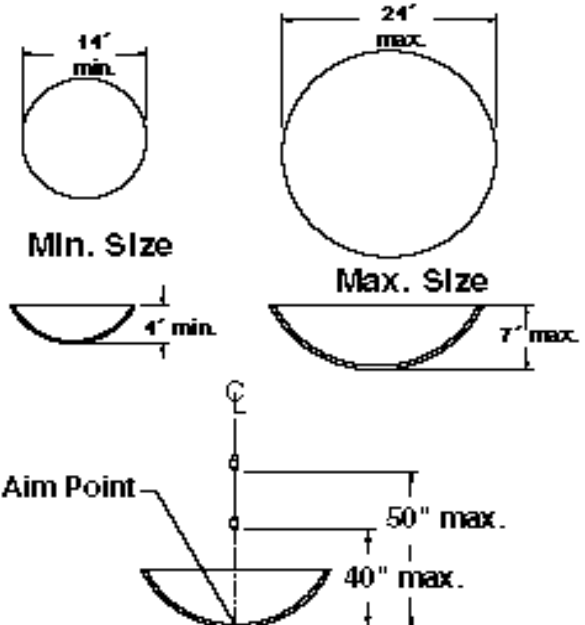

GRIDDLE PROTECTION – SINGLE FLOW POINT NOZZLE (P/N 11982)

The Amerex griddle nozzle (P/N 11982) has one flow point and will protect a griddle surface of 36 inches wide (91 cm) x 30 inches deep (76 cm). The nozzle must be located along the perimeter of the appliance and within a vertical height range from 30" to 48" (76 – 122. cm) above the surface of the appliance. The aiming point for the nozzle is the "point of intersection" of a straight line from the nozzle location to the center of the appliance, with an 11" (28 cm) square, generated about the center point of the griddle.

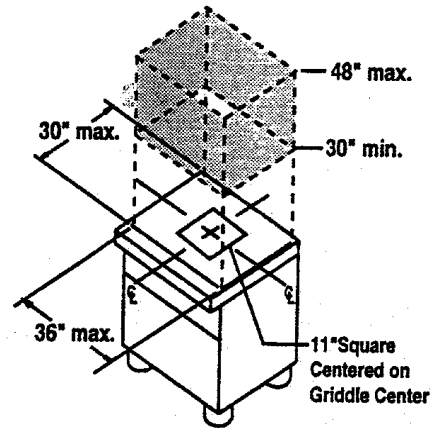

Note: Maximum & minimum heights must be measured from the tip of nozzle to the surface of the appliance.

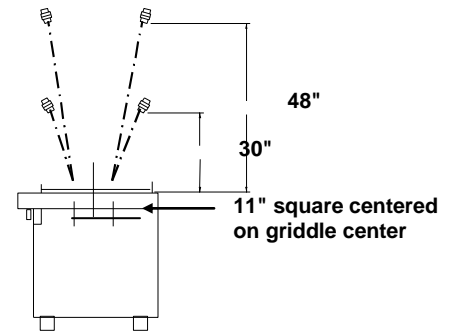
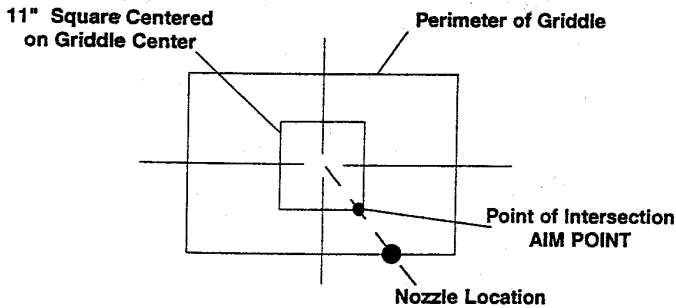

GRIDDLE PROTECTION – MULTIPLE SINGLE FLOW POINT NOZZLES (P/N 11982)

Multiple Amerex griddle nozzles (P/N 11982 – one flow point) may be used to protect a griddle surface area greater than 30 inches (76 cm) X 36 inches (91 cm). The griddle must be divided into modules for single nozzle coverage and the nozzles located and aimed for each module as indicated for single nozzle coverage.

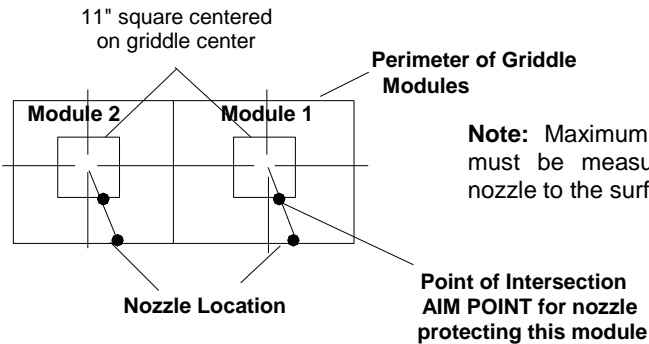
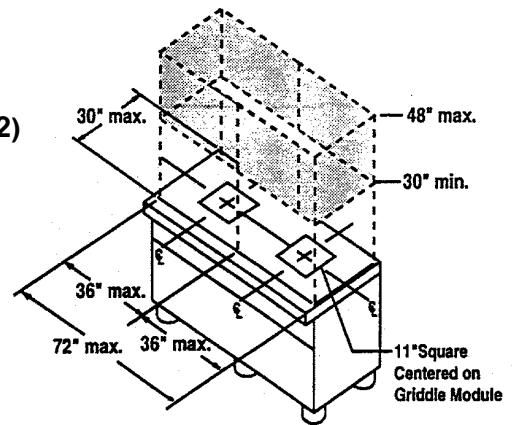

Note: Maximum & minimum heights must be measured from the tip of nozzle to the surface of the appliance.

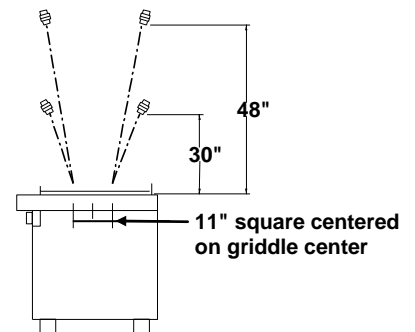

GRIDDLE PROTECTION – OVERHEAD TWO FLOW POINT NOZZLE (P/N 13729)

The Amerex fryer and griddle nozzle (P/N 13729) has two flow points and will protect a griddle surface of 42 inches wide (107 cm) X 30 inches deep (76 cm). The nozzle must be located within 6 inches (15 cm) of either side of the appliance centerline, placed 38 inches (97 cm) to 50 inches (127 cm) above the cooking surface and aimed straight down.

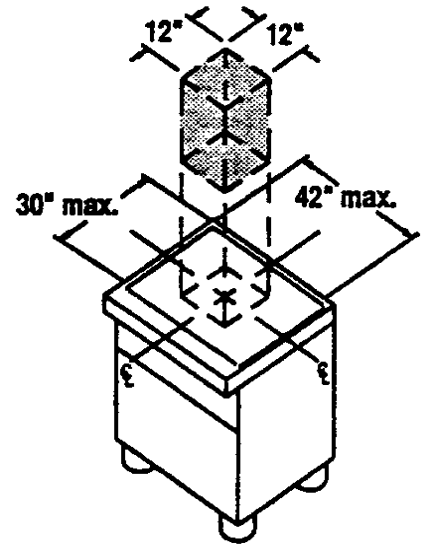

Note: Maximum & minimum heights must be measured from the tip of nozzle to the surface of the appliance.

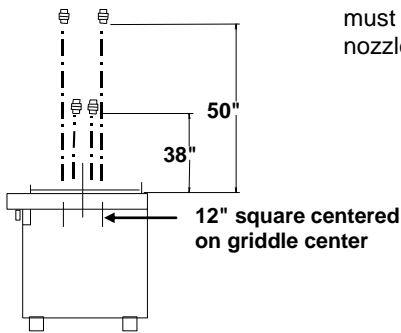

GRIDDLE PROTECTION – OVERHEAD MULTIPLE TWO FLOW POINT NOZZLES (P/N 13729)

Griddles exceeding 30 inches (76 cm) X 42 inches (107 cm) may be protected using multiple two flow point nozzles by dividing the surface area into equal modules. Each module requires one nozzle and cannot exceed an area larger than 42 inches length (107 cm) X 30 inches deep (76 cm).

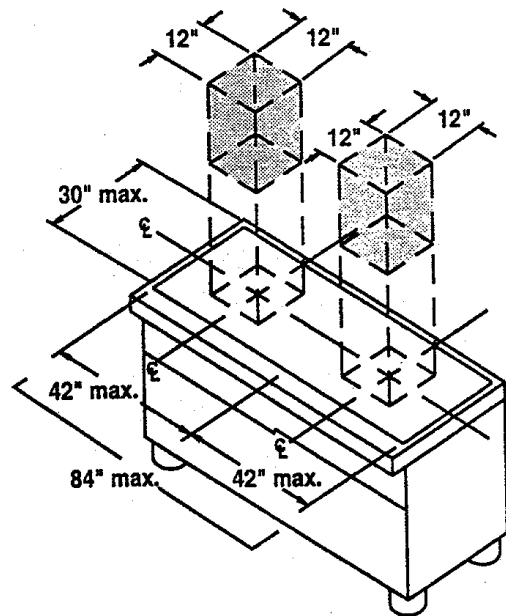

Note: Maximum & minimum heights must be measured from the tip of nozzle to the surface of the appliance.

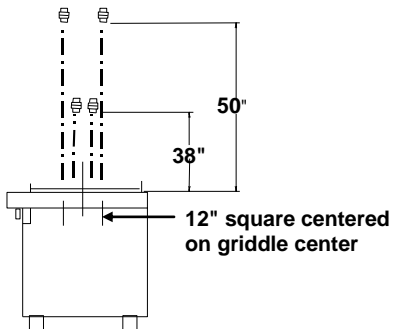

GRIDDLE PROTECTION - LARGE TWO (2) FLOW POINT NOZZLE (P/N 14178)

The Amerex Range Nozzle (P/N: 14178) has two (2) flow points and will protect a griddle surface of 48 inches wide (122 cm) x 30 inches deep (76 cm). The nozzle must be located along the perimeter of the appliance and within a vertical height range from 24" (61 cm) to 50" (127 cm) above the surface of the appliance. The aiming point for the nozzle is the "**Point of Intersection**" of a straight line from the nozzle location to the center of the appliance, where the line crosses the outer edge of an 11 inch square (28 cm sq.), centered over the center point of the griddle.

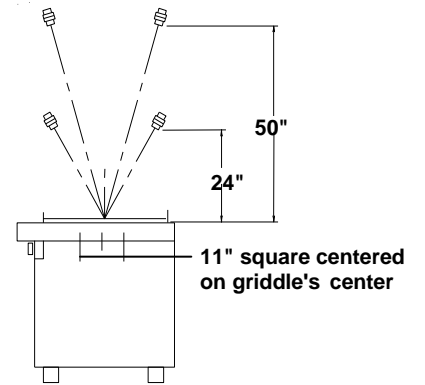
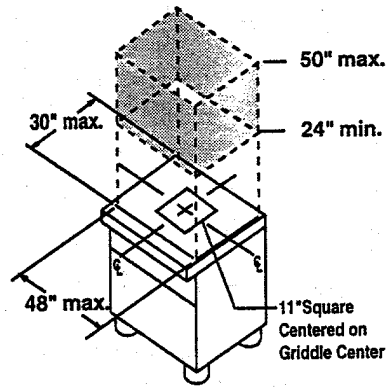

Note: maximum & minimum heights must be measured from the tip of nozzle to the surface of the appliance.

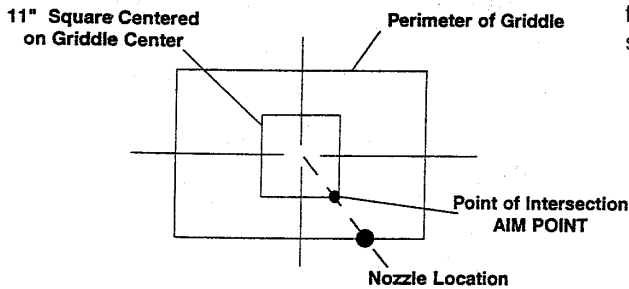

GRIDDLE PROTECTION - LOW PROXIMITY TWO (2) FLOW POINT NOZZLE (P/N 14178)

The Amerex Range Nozzle (P/N: 14178) has two (2) flow points and will protect a griddle surface of 48 inches wide (122 cm) x 30 inches deep (76 cm). The nozzle must be located at any one of the **four corners** of the appliance and within a vertical height range from 15" (38 cm) to 24" (61 cm) above the surface of the appliance. The aiming point for the nozzle is the "**Point of Intersection**" of a straight line from the nozzle location to the center of the appliance, where the line crosses the outer edge of an 11 inch square (28 cm sq.), centered over the center point of the griddle.

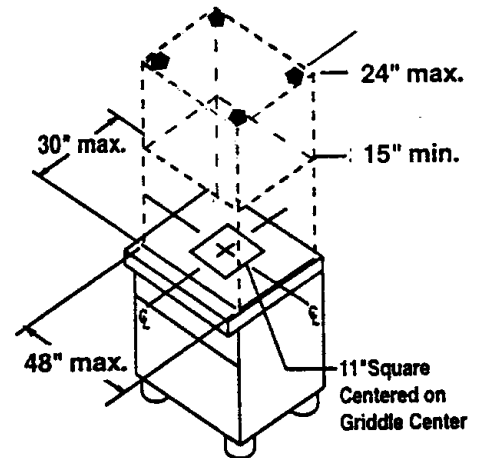

Note: Maximum & minimum heights must be measured from the tip of nozzle to the surface of the appliance.

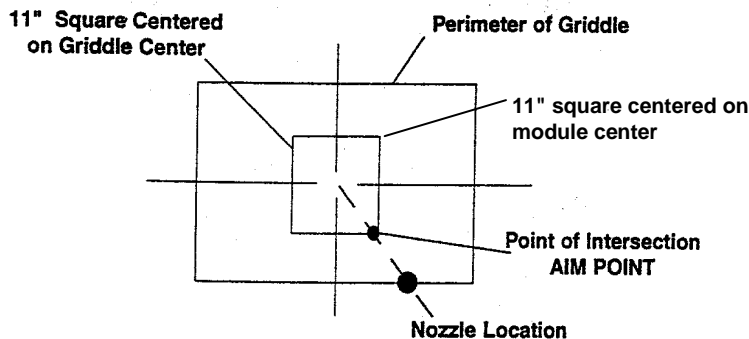
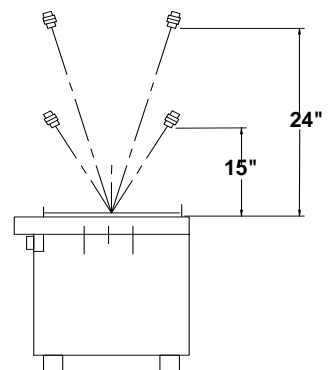

**GAS RADIANT CHARBROILER PROTECTION
SINGLE FLOW POINT NOZZLE (P/N 11982)**

One Amerex plenum nozzle (P/N 11982) will protect a gas radiant charbroiler with a cooking surface measuring 24 inches X 24 inches (61 x 61cm) maximum. The nozzle uses one flow point. It must be located 18 to 48 inches (46 – 122 cm) above the cooking surface and anywhere along or within the perimeter aimed towards the center.

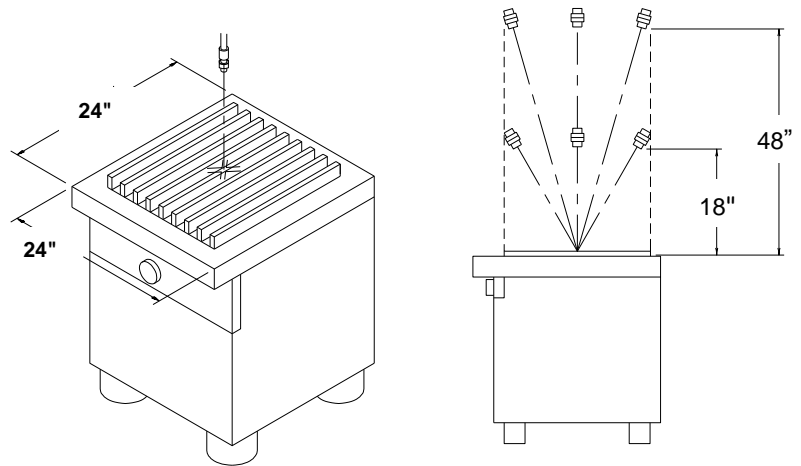

**ELECTRIC RADIANT CHARBROILER PROTECTION
SINGLE FLOW POINT NOZZLE (P/N 11982)**

Note: Electric charbroilers with a non-grated surface or a solid ribbed surface may be protected using the same limitations as a griddle.

Electric charbroilers with an open grate may be protected with one Amerex appliance, plenum nozzle (P/N 11982) provided that the area is no larger than 24 inches X 24 inches (61 x 61 cm). The nozzle uses one flow point and must be located within 18 – 48 inches (46 – 122 cm) above the grate surface, anywhere along or within the perimeter of the protected area, aimed towards the center.

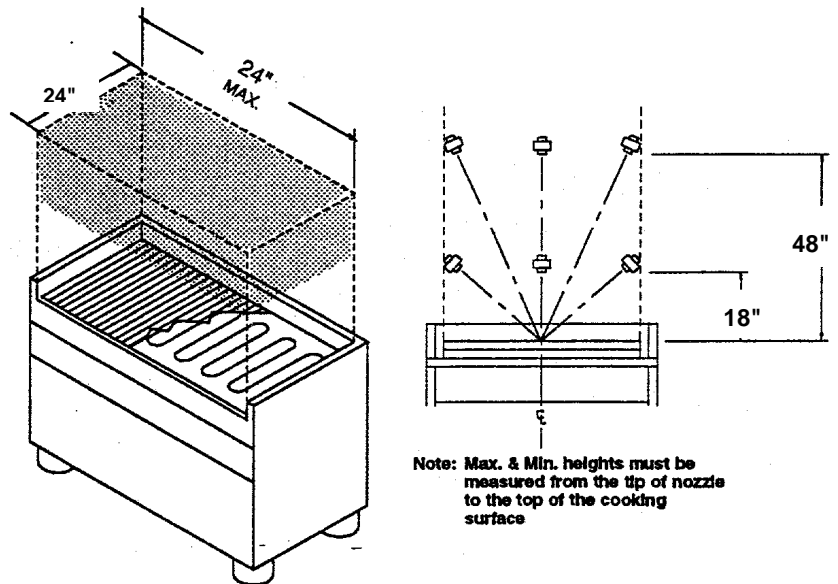

**LAVA ROCK (CERAMIC/SYNTHETIC) CHARBROILER
SINGLE FLOW POINT NOZZLE (P/N 11983)**

A single Amerex solid fuel appliance plenum nozzle (P/N 11983) will protect a lava rock charbroiler with a maximum cooking surface of 24 inches wide (61 cm) by 24 inches deep (61 cm). The appliance nozzle uses 1 ½ flow point and for this application must be located between 18 to 44 inches (46 to 122 cm) above the cooking surface anywhere along or within the perimeter of the appliance aimed toward the center.

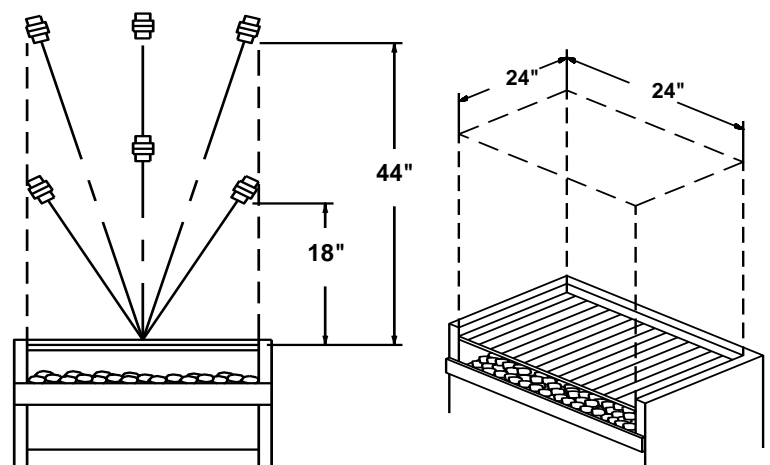

SOLID FUEL APPLIANCES

NATURAL AND MESQUITE CHARCOAL CHARBROILER ONE AND ONE HALF (1½) FLOW POINT NOZZLE (P/N 11983)

One Amerex solid fuel appliance nozzle (P/N 11983) will protect a charcoal charbroilers with a cooking surface measuring 28½ inches x 24 inches (72 cm x 61 cm) maximum. The nozzle uses one and one half flow points. It must be located 16 to 42 inches (41 cm – 107 cm) above the cooking surface and anywhere along or within the perimeter aimed at the center. The fuel depth is limited to 6 inches (15 cm) maximum.

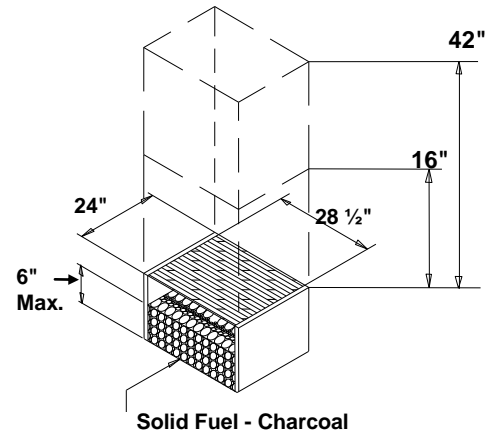

MESQUITE CHIPS & CHUNKS CHARBROILER ONE AND ONE HALF (1½) FLOW POINT NOZZLE (P/N 11983)

A single Amerex solid fuel appliance nozzle (P/N 11983) will protect a mesquite charbroilers with a maximum cooking surface of 28½ inches X 24 inches (72 cm X 61 cm). The nozzle uses one and one half (1½) flow points and for this application must be located between 16 to 48 inches (41 cm to 122 cm) above the cooking surface anywhere along or within the perimeter of the appliance aimed at the center of the appliance. The fuel depth is limited to 6 inches (15 cm) maximum.

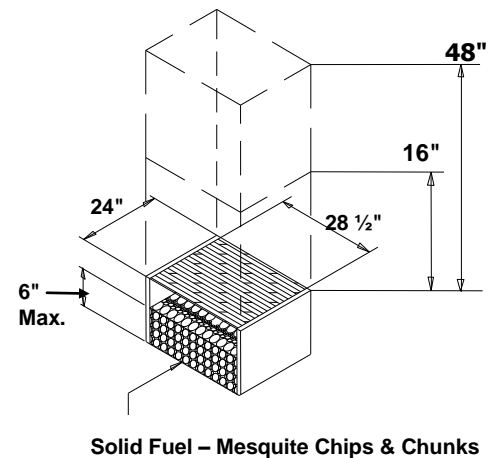

MESQUITE LOG CHARBROILER ONE AND ONE HALF (1½) FLOW POINT NOZZLE (P/N 11983)

A single Amerex solid fuel appliance nozzle (P/N 11983) will protect a mesquite log charbroilers with a maximum cooking surface of 28½ inches X 24 inches (72 cm X 61 cm). The nozzle uses one and one half (1½) flow points and for this application must be located between 19 to 44 inches (48 cm to 112 cm) above the cooking surface anywhere along or within the perimeter of the appliance aimed at the center of the appliance. Solid fuel is limited to three (3) layers of logs or 11 inch (28 cm) maximum stacked height.

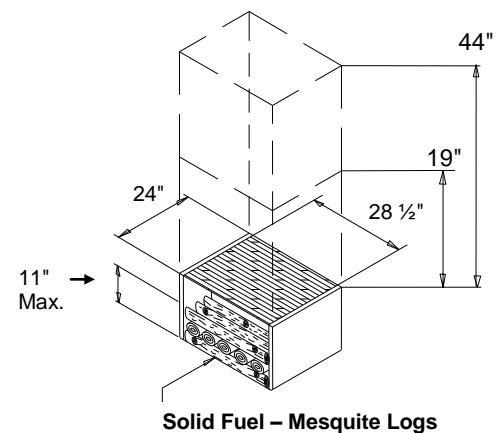

UPRIGHT BROILER PROTECTION TWO HALF FLOW POINT NOZZLES (P/N 11984)

Two Amerex upright broiler nozzles are required for this application. Each upright broiler nozzle (P/N 11984) equals a ½ flow point. **These nozzles must always be used in pairs equaling one flow point** and will protect an internal broiler chamber measuring 30 ½" X 28 ½" (77 x 72 cm). The nozzles must be positioned at the front opening of the broiler with the top nozzle located above the grate, aimed toward the opposite rear corner and the lower nozzle located the grate and aimed toward the center of the drip pan.

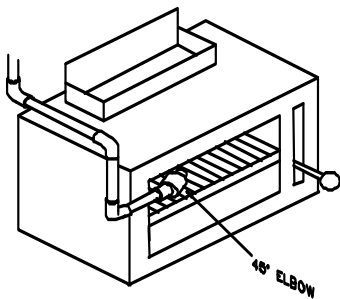
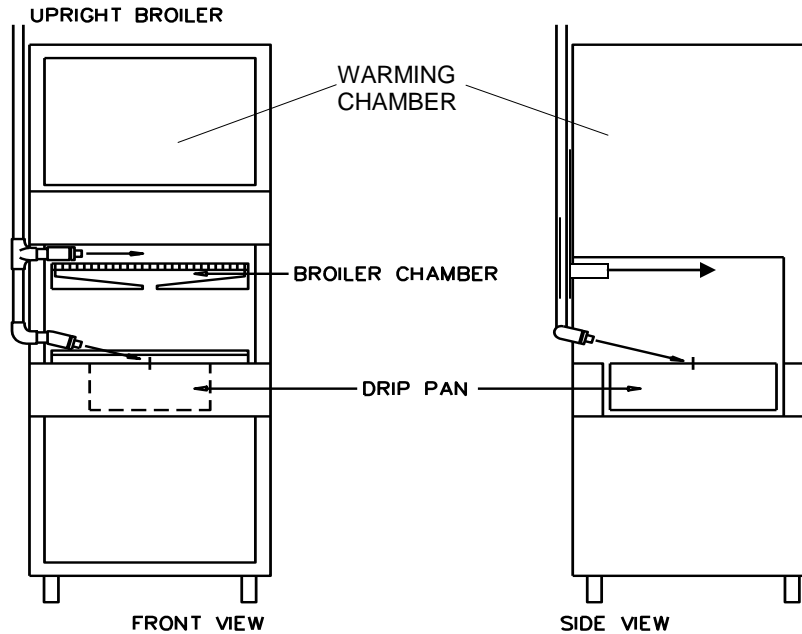

NOTE: PROTECTION FOR SALAMANDERS AND CHEESE MELTERS UP TO 38" (96.5cm) IN LENGTH SHOULD BE ACCOMPLISHED USING A SINGLE FLOW APPLIANCE NOZZLE P/N 11982 LOCATED IN THE MIDDLE OF THE OPENING AND AIMED AT THE REAR OPPOSITE CORNER.

OPTIONAL : PROTECTION MAY ALSO BE ACCOMPLISHED BY USING TWO HALF FLOW POINT NOZZLES P/N 11984 , BOTH NOZZLES LOCATED ON THE SAME SIDE OF THE SALAMANDER, POSITIONED IN THE MIDDLE OF THE UPPER AND LOWER OPENING, AIMED TO THE REAR OPPOSITE CORNER.

**CLOSED TOP CHAIN BROILER
SINGLE FLOW POINT NOZZLE (P/N 11982)**

The Amerex appliance/plenum nozzle (P/N11982) has one flow point and will protect a closed top chain broiler with a cooking area of 24 1/2" x 31" (62 X 79 cm). The nozzle is to be located on the side opposite the external drip pan (when present), positioned in the middle of the inlet opening and aimed at the opposite rear corner.

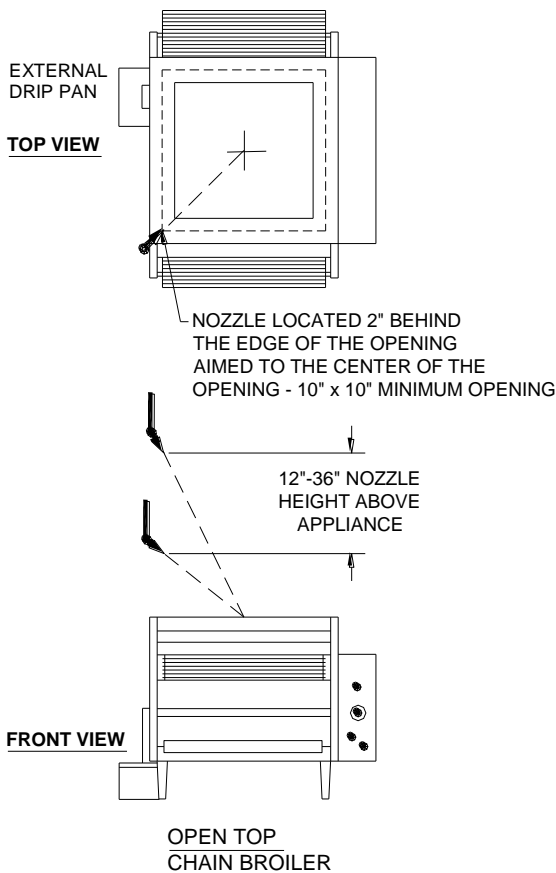
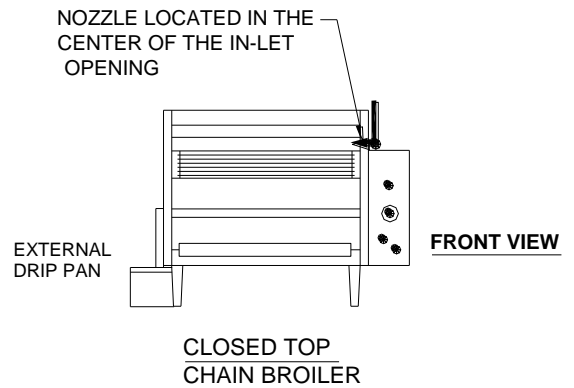
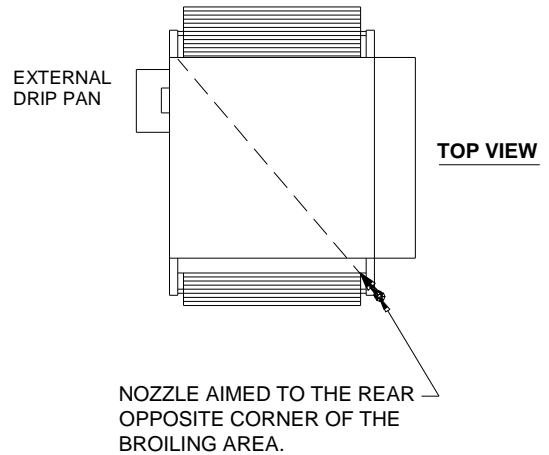

**OPEN TOP CHAIN BROILER
TWO FLOW POINT NOZZLE (P/N 13729)**

The Amerex fryer nozzle (P/N13729) has two flow points and will protect an open top chain broiler with a cooking area of 24 1/2" x 31" (62 x 79 cm). The minimum opening is 10" x 10" (25.4 x 25.4 cm) and the nozzle is to be positioned 2" behind the edge of the opening, at a height of 12" – 36" (30.5 - 91 cm) above the appliance and aimed at the center of the opening.

Note: Maximum & minimum heights must be measured from the tip of nozzle to the surface of the appliance.

**NIECO MODEL 9025 - BURGER KING CHAIN BROILER
 TWO – SINGLE FLOW POINT NOZZLE (P/N 11982)**

The Nieco Chain Broiler Model 9025 is a unique appliance and when fitted with two catalysts it requires the use of two Amerex nozzles (P/N11982) to protect each half of the appliance. Total appliance protection therefore, requires the use of a total of four Amerex nozzles (P/N 11982). This unique appliance is actually two chain broilers put together to accommodate the cooking of two different products at the same time. This appliance can be fitted with two catalysts (18" x 24" overall) one for each cooking side.

The protection of the appliance is accomplished by using two nozzles P/N 11982 positioned two inches outside of the catalyst perimeter aimed at the center point of the catalyst. The nozzles are to be located on opposite ends of the catalyst, 180° apart and are to be 13" to 36" above the top surface of the catalyst. This configuration is repeated for both cooking sides of the appliance. If no catalyst is used the same protection is required for the unit.

Note: Maximum & minimum heights must be measured from the tip of nozzle to the top surface of the catalyst or appliance (if no catalyst is used).

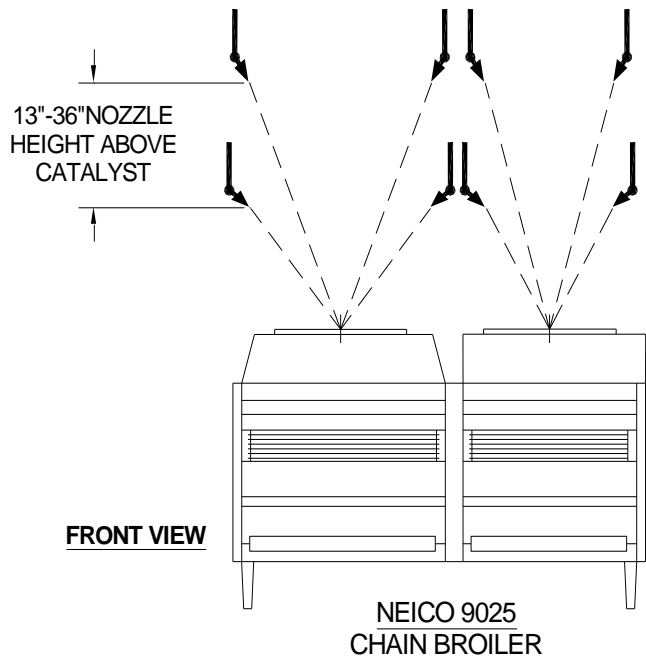
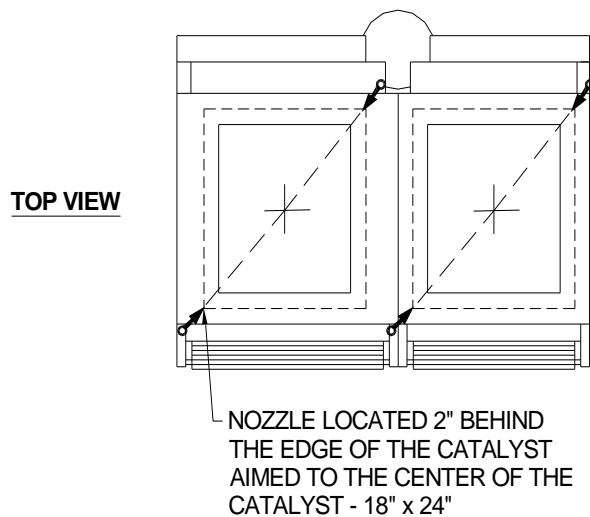

**DUKE MODEL - BURGER KING CHAIN BROILER
TWO – TWO FLOW POINT NOZZLE (P/N 13729)**

The Duke Chain Broiler is a unique appliance and is fitted with a catalyst that requires the use of two Amerex nozzles (P/N13729). This unique appliance operates at an extremely high temperature in order to cook large quantities of frozen burgers in a short span of time.

The protection of the appliance is accomplished by dividing the catalyst area into two equal modules and positioned one nozzle P/N 13729 on the perimeter of each module, aimed at the center of the module. The nozzles are to be located anywhere on the module perimeter 15" to 30" (38.1cm – 76.2cm) above the top surface of the appliance. If no catalyst is used the same protection is required. The addition of a damper on top of the catalyst does not change the protection required for the unit.

Note: Maximum & minimum heights must be measured from the tip of nozzle to the top surface of the catalyst or appliance (if no catalyst is used).

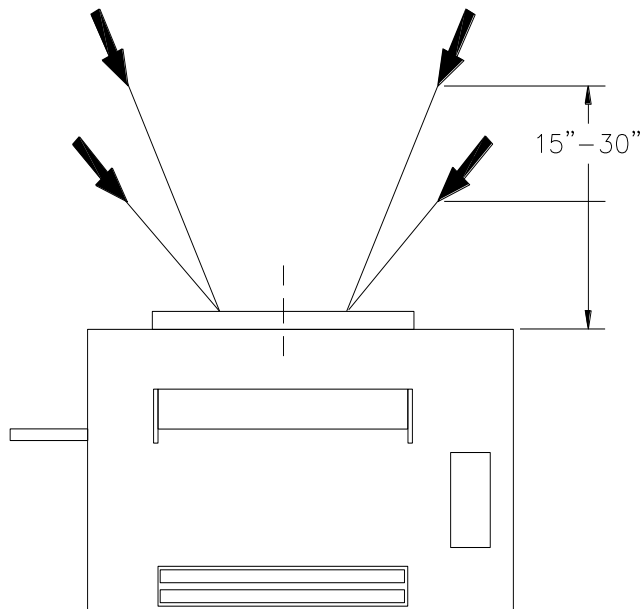

FRONT VIEW

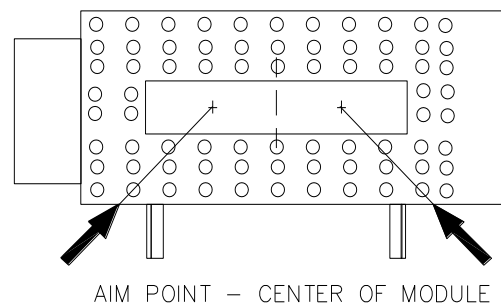

TOP VIEW

**DUKE MODEL - BURGER KING CHAIN BROILER
 TWO – ONE FLOW POINT NOZZLE (P/N 11982)**

The Duke Chain Broiler is a unique appliance and is fitted with a catalyst that requires a flue guard to direct the exhaust gases. Protection is accomplished with the use of two Amerex nozzles (P/N11982). This unique appliance operates at an extremely high temperature in order to cook large quantities of frozen burgers in a short span of time.

The protection of the appliance is accomplished by dividing the catalyst area into two equal modules and positioned one nozzle P/N 11982 2.5”inboard of the edge of the appliance & aimed at the center of the module. The nozzles are to be located as illustrated below. If no catalyst is used the same protection is required. (The addition of a damper on top of the catalyst changes the protection required for appliance to that illustrated on Page 3-21.)

Note: Nozzle heights must be measured from the tip of nozzle to the top surface of the catalyst or appliance (if no catalyst is used).

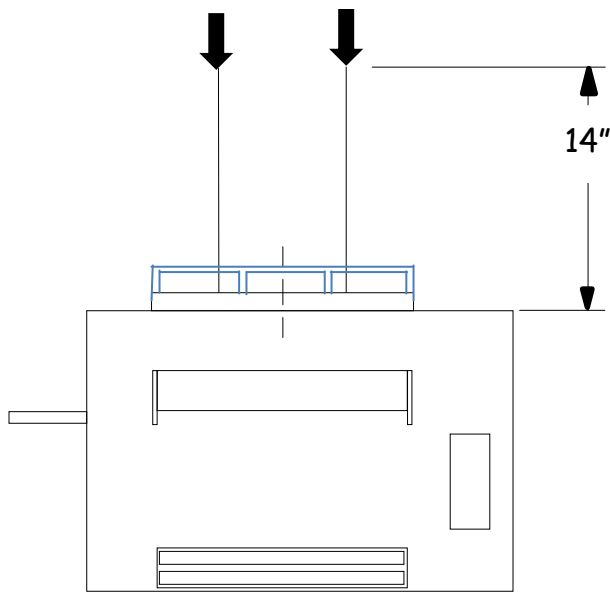

FRONT VIEW

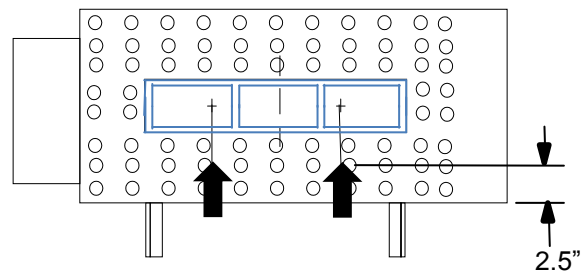

AIM POINT – CENTER OF MODULE

TOP VIEW

DUKE CHAIN BROILER & DUKE HOOD EXHAUST HOOD TWO – TWO FLOW POINT NOZZLE (P/N 13729)

The Duke Chain Broiler and Hood combination is a special design just for the Duke product. The hood and broiler are each fitted with a catalyst to decrease the emission of grease laden vapors into the exhaust duct system. The hood comes pre-piped for the installation of the fire suppression nozzles. This unique appliance operates at an extremely high temperature in order to cook large quantities of frozen burgers in a short span of time.

The protection of this unit is accomplished by using two (2) Nozzles P/N 13729 installed in the piping provided so that it will spray agent into the catalyst as illustrated. A third nozzle P/N 16416 is installed for duct protection of the 8" diameter exhaust duct.

If no catalyst is used the same protection is required. The addition of a damper on top of the broiler catalyst does not change the protection required for the unit. Due to the extreme heat of the appliance close inspection of the nozzles is to be performed at each six month service interval. Nozzle replacement is required at the signs of any nozzle deterioration.

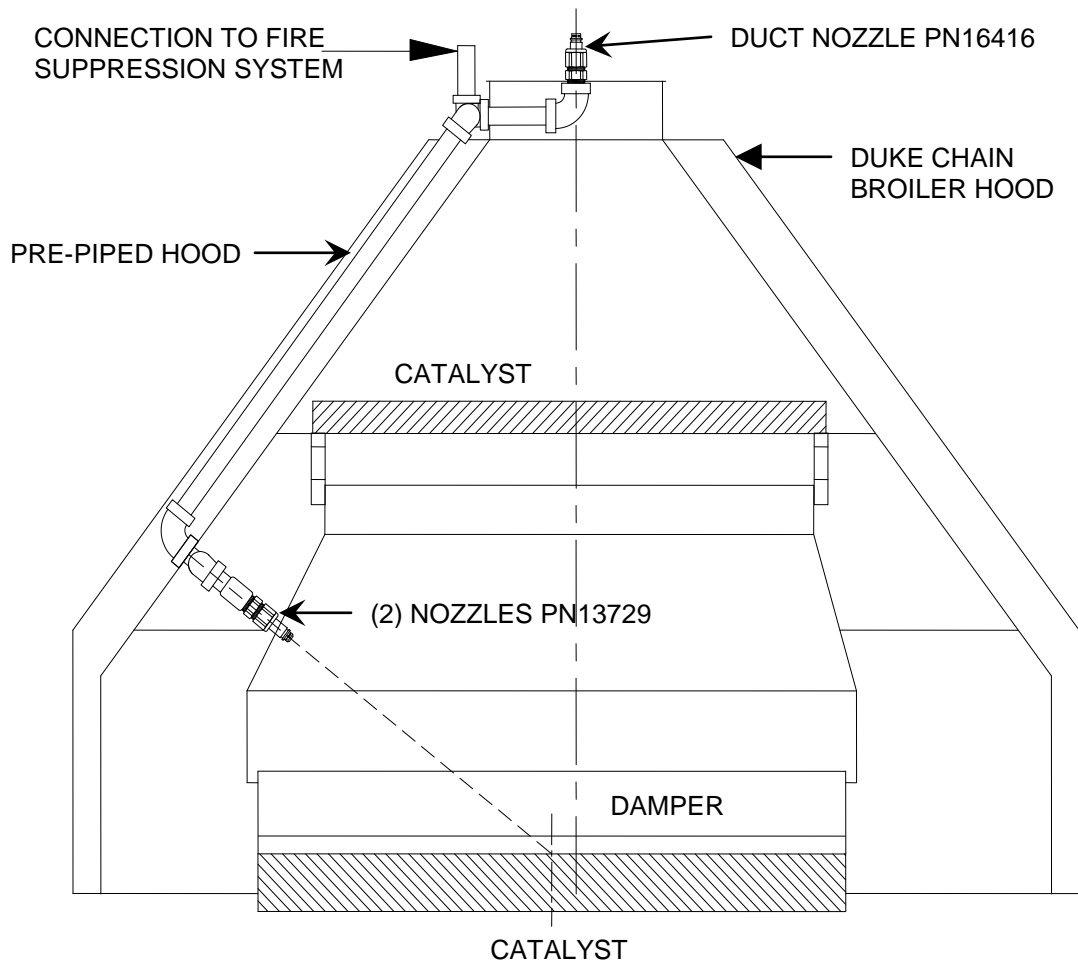

Back shelf – What to do?

The use of a back-shelf presents a problem to the designer of a kitchen fire suppression system for it is an impediment to the delivery of the wet chemical to the potential fire hazard. The same is true for salamanders that are mounted over an appliance requiring protection. A shelf or salamander that extends over the appliance not only prevents proper delivery of wet chemical but also is a fire hazard. All too often, these shelves become storage places for items such as paper plates, doggie bags, or flammable food preparation liquids. The overhead application of the wet chemical from an Amerex Restaurant Fire Suppression System would be of help in extinguishing a fire occurring in items placed on a back-shelf, but that is not the intended hazard for which the system was designed. The shelf or salamander prevents agent, from an overhead nozzle, from reaching the actual cause of fire in the appliance.

Amerex has developed the only real world solution to this problem. When a shelf is installed over a range or a griddle, a small manifold of three special nozzles provides fire suppression protection. The BSM (back-shelf manifold) is designed to function as supplemental agent application for the area under the back-shelf. It replaces the agent lost because of the shelf. It provides an area of protection 15" deep and 42" wide when used over a range.

The back-shelf or salamander can extend 1" beyond the centerline of the appliance with the manifold nozzle tips located 14" to 19" above the appliance. The first nozzle must be placed $\frac{1}{2}$ " outside the edge of the hazard and on the centerline of the hazard area covered by the shelf.

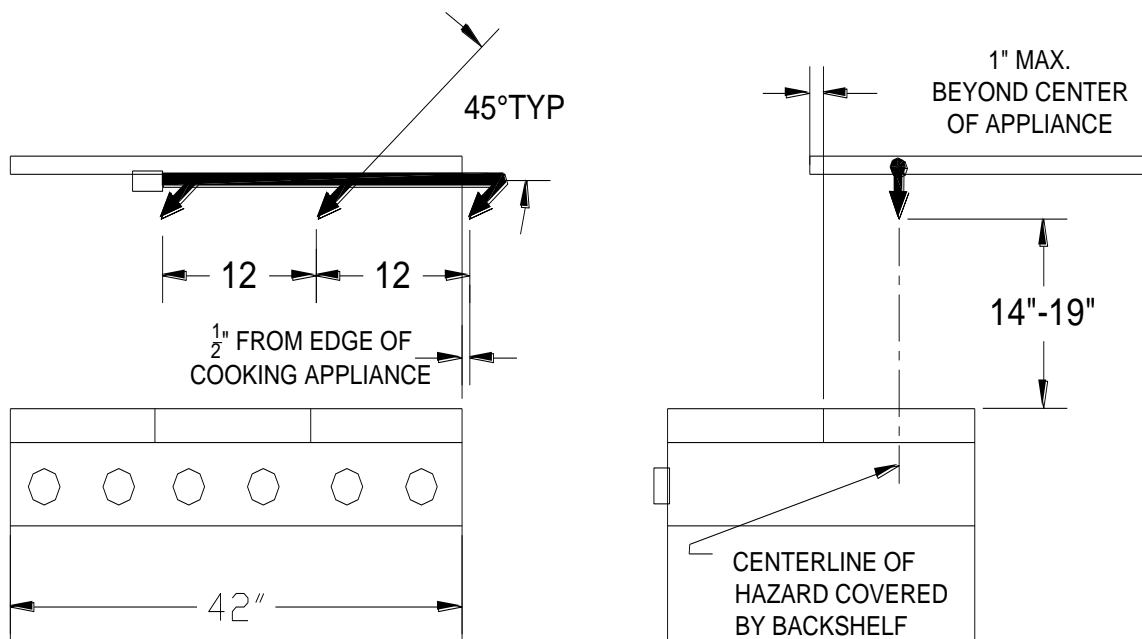

SIX BURNER RANGE - FRONT VIEW

RANGE - RIGHT SIDE VIEW

BSM: Back Shelf Manifold Asy. – (P/N 17461 with nozzles)

The BSM (P/N 17461) is comprised of three Amerex nozzles, positioned on a 45° angle and spaced 12" apart. All nozzles are in the same plane of alignment and at the same height. This is accomplished by the use of the Amerex manufactured manifold. The manifold is constructed from a custom aluminum extrusion which is machined to the precise requirements needed to maintain proper alignment of the nozzles. Connection to the nozzle branch piping may be made from either end of the assembly. The opposite end of the assembly is to be plugged with a 3/8" pipe plug. The manifold should appear as illustrated.

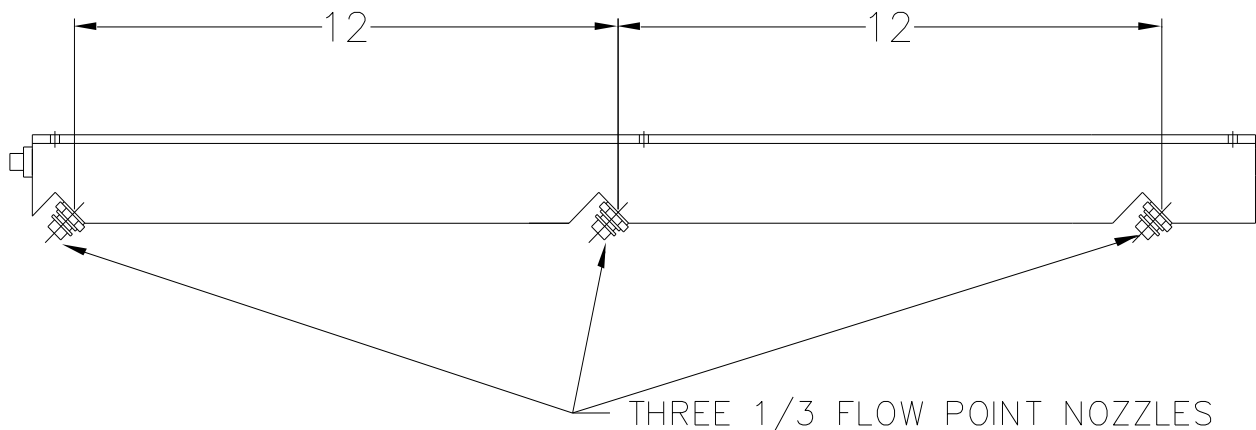

The BSM is to be used as an assembly of three nozzles and will carry a flow point value of one (1).

It is designed to extinguish fires located under the back shelf when they occur on the back three burners of a six-burner range (15" x 42") or the back portion of a griddle. It never takes the place of the overhead nozzle, but simply provides additional agent to extinguish any and all fires beneath the back shelf or salamander.

The same limitations apply to salamanders that are applied to back shelves.

When the BSM is used to protect a griddle positioned under a back shelf, the manifold is installed on the centerline of the portion of the griddle covered by the back shelf or salamander. The maximum amount of back shelf coverage allowed for griddles is 16". The location of the overhead nozzle is always to be to the front edge of the griddle. See required nozzle and aiming requirements on the next pages for details on griddle protection.

The following pages are examples of manifold placement under several conditions of back shelf use. The following schematics represent the only nozzle combinations permitted with a BSM.

Note: When using the BSM assembly for range protection only the Range Nozzle (14178) is permitted in the overhead protection position as indicated on the schematics.

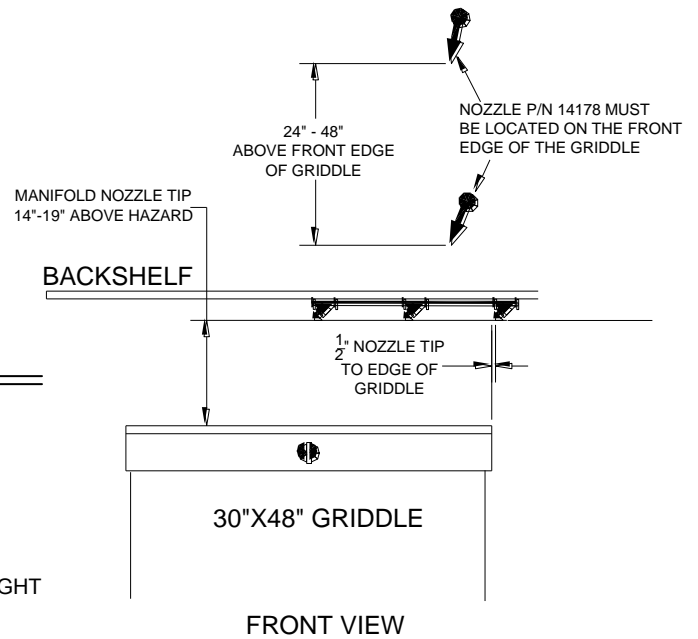
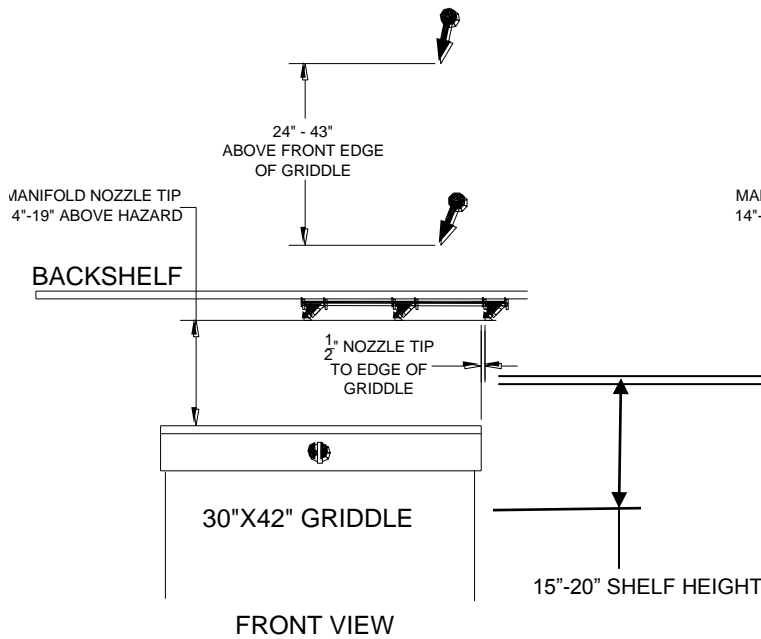
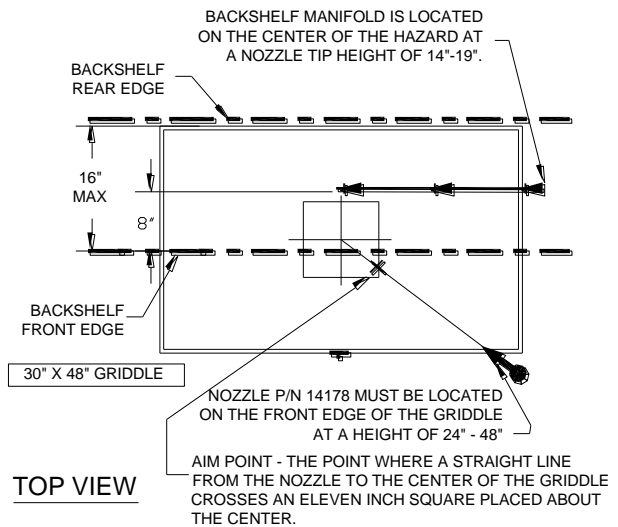
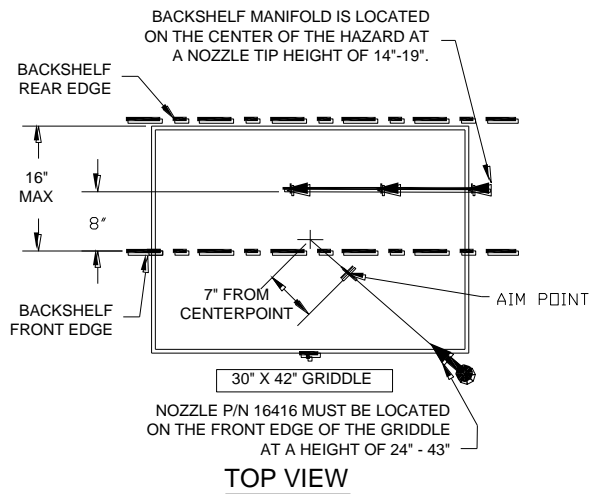

The schematic above shows the protection method on two different size griddles (30"x42" & 30"x48") that are positioned under a back-shelf. Note that the shelf extends 1" beyond the center of the griddle (16") and covers the entire width of the griddle, all which are within the parameters of the listing. Also, recognize that the centerlines of the manifolds are congruent with the centerline of the hazard covered by the back-shelf. Each manifold must be located on the centerline of the hazard area it is to protect.

The P/N16416 nozzle plus a BSM (back-shelf manifold) will protect griddles up to 30"x42" maximum, with a back-shelf that covers no more than 16" of griddle. Total flow point value is 2 flow points. The overhead nozzle must be located on the front edge of the griddle aimed at a point 7" back from the center of the hazard area on a straight line from the nozzle to the center of the hazard.

The P/N14178 nozzle plus a BSM (back-shelf manifold) will protect griddles up to 30"x48" maximum, with a back-shelf that covers no more than 16" of griddle. Total flow point value is 3 flow points. The overhead nozzle must be located on the front edge of the griddle aimed at a point where a straight line from the nozzle to the center of the griddle crosses an 11" square placed over the center of the griddle.

The schematic below shows the protection of a six-burner range (28"x42") that is positioned under a back-shelf. Note that the shelf extends 1" beyond the center of the range and covers 15" of the burners, all which are within the parameters of the listing. The manifold must be located on the centerline of the hazard area it is to protect. A P/N14178 nozzle is used for the protection of a group of four burners in the typical overhead position. The arrangement below places the second nozzle in the most optimum position for protection of a six-burner range.

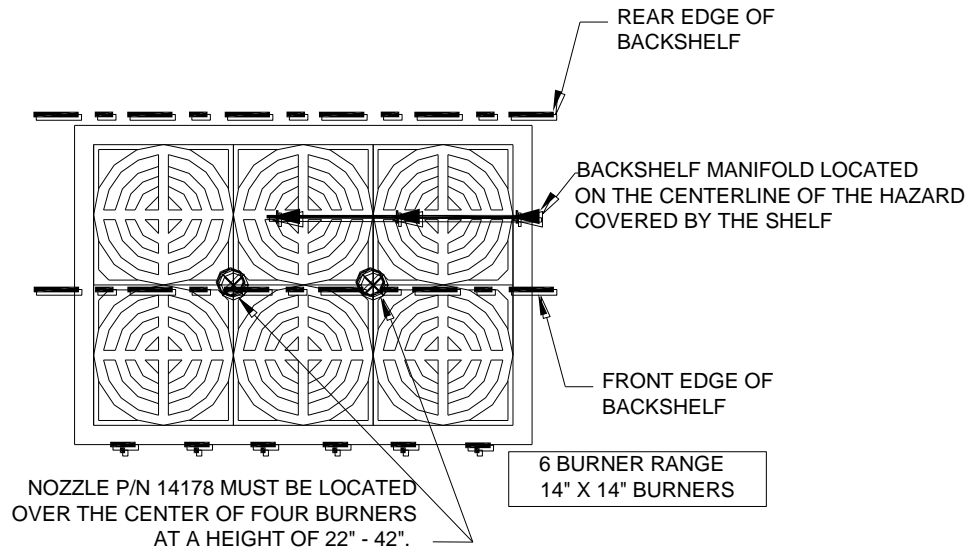

TOP VIEW

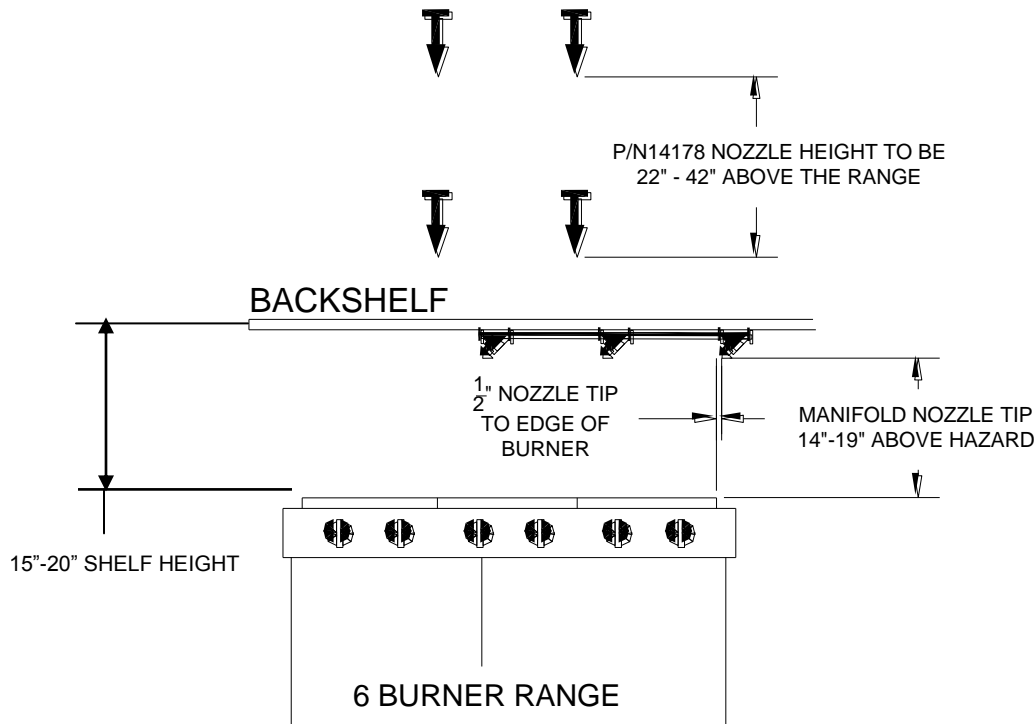

FRONT VIEW

The schematic below shows the protection of a griddle (30"x42") & a six-burner range (12" burners) that are positioned under a back-shelf. Note that the back-shelf extends 1" beyond the center of the range and covers 16" of the griddle, all which are within the parameters of the listing. Also, recognize that the centerlines of the two manifolds are not congruent. Each manifold must be be located on the centerline of the hazard area it is to protect.

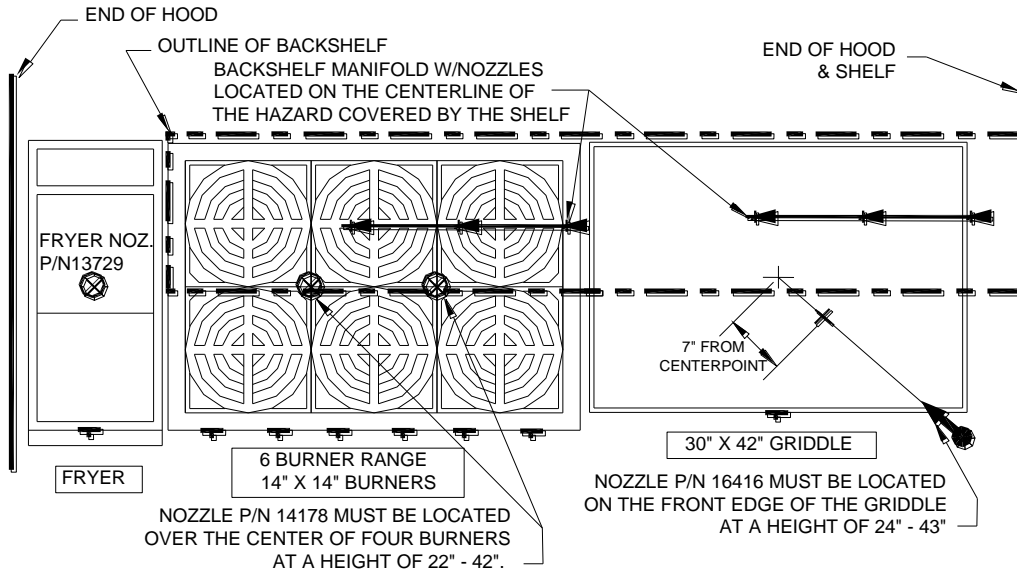

TOP VIEW

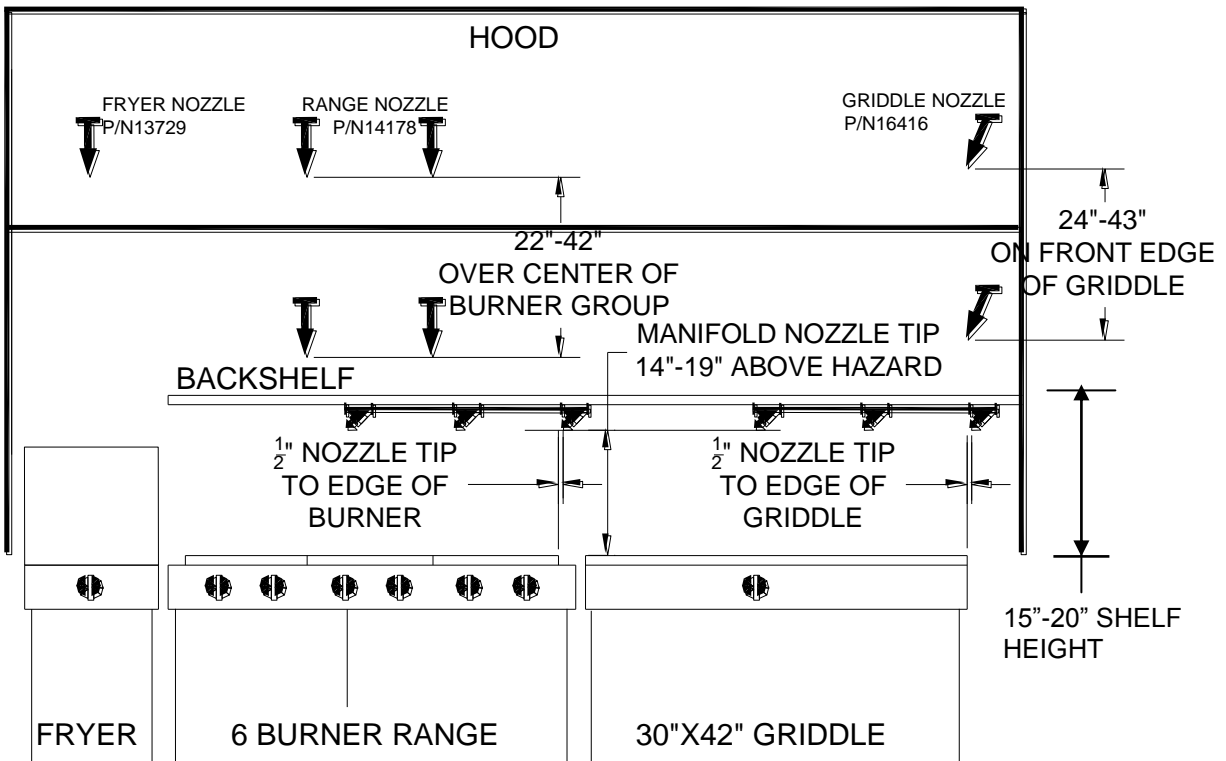

FRONT VIEW

AMEREX KP RESTAURANT SYSTEM NOZZLE APPLICATION CHART

Appliance	Nozzle P/N	Flow Points	Width	Length	Min. Height	Max. Height
Deep Fat Fryer – without Drip Board	13729	2	19 ½ in.	19 in.	36 in.	48 in.
Deep Fat Fryer – with Drip Board	13729	2	19 ½ in.	25 3/8 in.	36 in.	48 in.
Deep Fat Fryer – without Drip Board	13729	2	26	24	36 in.	50 in.
Deep Fat Fryer – with 1” Drip Board	13729	2	26	25	36 in.	50 in.
Deep Fat Fryer – with Drip Pan Low Proximity	2-11982	2	19 ½ in.	25 3/8 in.	17 ½ in.	36 in.
Range – Single Burner	11984	½	18 in.	18 in.	20 in.	42 in.
Range – Two Burner (14” Burner)	11982	1	14 in.	28 in.	44 in.	48 in.
Range – Two Burner (12” Burner)	11982	1	12 in.	24 in.	36 in.	50 in.
Range- Two Burners w/Back Shelf (12” Burner)	11982	1	12 in.	24 in.	40 in.	47 in.
Low Back-Shelf/Salamander – BS Manifold	17461	1	14 in.	42 in.	14 in.	19 in.
Range – Three Burners (Special Aiming)	2 - 11984	1	12 in.	36 in.	20 in.	30 in.
Range – Four Burners (12” Burner)	14178	2	24 in.	24 in.	18 in.	50 in.
Wok	11982	1	14-24 dia.	4-7 depth	40 in.	50 in.
Griddle	11982	1	30 in.	36 in.	30 in.	48 in.
Griddle - Overhead Protection	13729	2	30 in.	42 in.	38 in.	50 in.
Griddle	14178	2	30 in.	48 in.	15 in.	50 in.
Upright Broiler	2-11984	1	30 ½ in.	28 ½ in.	-	-
Charbroiler (Lava Rock)	11983	1 ½	24 in.	24 in.	18 in.	44 in.
Charbroiler (Gas Radiant & Electric Radiant)	11982	1	24 in.	24 in.	18 in.	48 in.
Chain Broiler – Closed Top	11982	1	24½ in.	31 in.	-	-
Chain Broiler – Open Top	13729	2	24½ in.	31 in.	12 in.	36 in.
Chain Broiler – Nieco Model 9025 /Catalyst (2)	4 – 11982	4	18 in.	24 in.	13 in.	36 in.
Chain Broiler – Duke (with / without Catalyst or Damper)	2– 13729	4	-	-	15 in.	30 in.
Natural & Mesquite Charcoal Charbroiler	11983	1 ½	24 in.	28 ½ in.	16 in.	42 in.
Mesquite Chips & Chunks Charbroiler	11983	1 ½	24 in.	28 ½ in.	16 in.	48 in.
Mesquite Log Charbroiler	11983	1 ½	24 in.	28 ½ in.	19 in.	44 in.
Plenum	Nozzle P/N	Flow Points	Width	Length		
Single Bank/V-Bank	11982	1	4 ft.	10 ft.		
Duct	Nozzle P/N	Flow Points	Max. Perimeter	Diameter	Length	Max. Diagonal
Rectangular	16416	1	50 in.	-	Unlimited	18.8 in.
Circular	16416	1	-	16 in.	Unlimited	-
Rectangular	2-16416	2	51 to 82	-	Unlimited	18.8 in.
Circular	2-16416	2	-	26 in.	Unlimited	-
Rectangular	2-11983	3	100 in.	-	Unlimited	37.2 in.
Circular	2-11983	3	-	32 in.	Unlimited	-
Rectangular	3-11983	4 ½	150 in.	-	Unlimited	55.9 in.
Circular	3-11983	4 ½	-	48 in.	Unlimited	-

Protection is not limited to the items listed on this chart. Modulizing larger appliances are an acceptable practice. See your Amerex KP Manual for additional information.

AGENT QUANTITY AND CYLINDER SELECTION:

After reviewing the hazards and determining the number and type of nozzles that will be required, the quantity of agent and the number and type of cylinders must be selected. Adding the number of flow points that are needed for the system will determine the agent quantity and cylinder options.

- ONE 2.75 GALLON CYLINDER (P/N 16921) WILL SUPPLY SUFFICIENT AGENT FOR UP TO AND INCLUDING 8 FLOW POINTS.
- ONE 3.75 GALLON CYLINDER (P/N 13334) WILL SUPPLY SUFFICIENT AGENT FOR UP TO AND INCLUDING 11 FLOW POINTS.
- ONE 4.75 GALLON CYLINDER (P/N 17379) WILL SUPPLY SUFFICIENT AGENT FOR UP TO AND INCLUDING 14 FLOW POINTS.

Cylinders may be used together for multiple cylinder systems with one MRM, MRM II or PRM. A MAXIMUM OF 10 KP 275/375/475 AGENT CYLINDERS MAY BE USED PER MECHANICAL RELEASE MODULE OR PNEUMATIC RELEASE MODULE.

- ONE 6.14 GALLON CYLINDER (P/N 15196) WILL SUPPLY SUFFICIENT AGENT FOR UP TO AND INCLUDING 18 FLOW POINTS.

A MAXIMUM OF 6 KP 600 AGENT CYLINDERS MAY BE USED PER MRM, MRM II or PRM. ANY COMBINATION OF CYLINDERS INVOLVING THE KP600 CYLINDER IS LIMITED TO A TOTAL OF 6 CYLINDERS PER MRM, MRM II or PRM.

ACTUATION NETWORK LIMITATIONS – MRM, MRM II OR PRM

The actuation network for the Amerex Restaurant Fire Suppression System consists of factory supplied hose; installer supplied copper tubing or pipe that connects the MRM, MRM II or PRM to each cylinder discharge valve. A single MRM, MRM II or PRM is capable of actuating up to ten (10) 2.75 / 3.75 / 4.75 gallon agent cylinder discharge valves or six (6) 6.14 gallon agent cylinder discharge valves by discharging a single 10 in³ nitrogen cylinder (P/N 12856) through the actuation network. If the network is a combination of any of the 2.75, 3.75 and or 4.75 with a 6.14 gallon cylinder, then maximum number of cylinders is six (6).

Note: A vent plug (P/N 10173) must be placed in an accessible location anywhere in the actuation line to aid in releasing pressure after the system has discharged. See the RECHARGE Section 7.

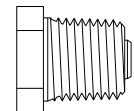

Vent Plug P/N 10173

LIMITATIONS (SINGLE OR MULTIPLE CYL SYSTEMS)

Copper tubing – ¼" O.D. refrigeration type with a minimum wall thickness of .049 inches. Use with brass or steel compression style fittings (with brass or steel sleeves or ferrules). Maximum length (including all fittings) 100 feet (30.48 m)

High Pressure Hose – ¼" I.D. wire braid hose that is factory supplied. Maximum length (including all fittings) 54 feet (16.46 m) or a maximum number of 40 hose assemblies P/N 12854, 20 hose assemblies P/N 16448, or any combination that does not exceed a total of 54 feet (16.56 m)

Pipe – ¼" NPT schedule 40 made of stainless steel, galvanized, chrome plated or black iron pipe:
Maximum length – 22.2 feet (6.77m)

Maximum tees – 9

Maximum elbows – 9 (note: 2 – 45° elbows = 90°)

Note: Different methods of constructing the actuation network may be mixed provided that the shortest limitations are followed,
Example: A mix of ¼" copper tubing and ¼" high pressure hose requires that the hose limitations be followed (no more than 54 feet [16.46m]) for the complete network. A mix of ¼" high pressure hose and ¼" pipe requires that the pipe limitations be followed (no more than 22.2 feet [6.77m]) for the complete work.

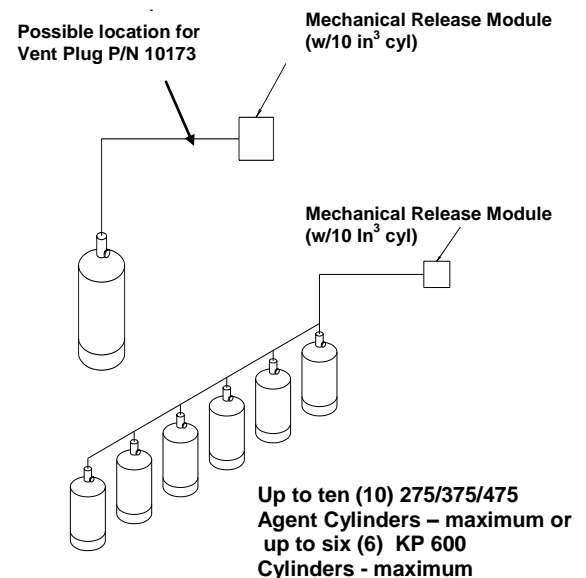

Nitrogen Cylinder	10 cu. in.	
Maximum Total Length for:	Feet	Meters
¼" Copper tubing	100	30.48
¼" ID Hose	54	16.46
¼" Schedule 40 Pipe	22.2	6.77

A Supply Line is the distribution piping that runs from the distributor outlet or discharge fitting to the first splitting tee.

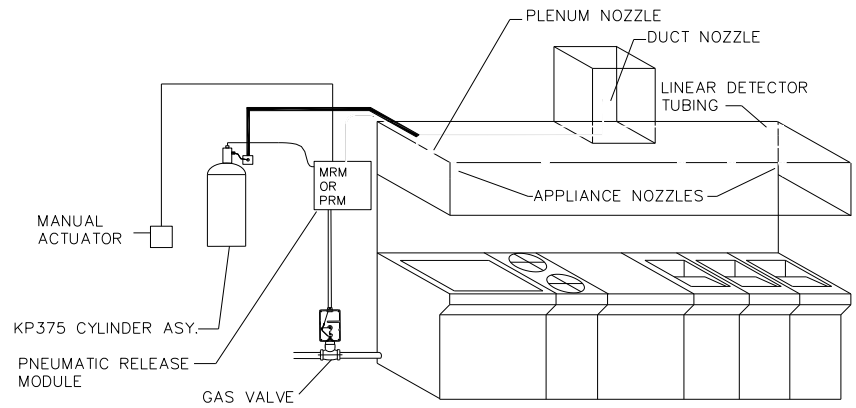

A Supply Branch Line (including the last nozzle branch) is the distribution piping that runs from the first tee at the hood to the last nozzle in the system including all fittings used to exit the supply branch line.

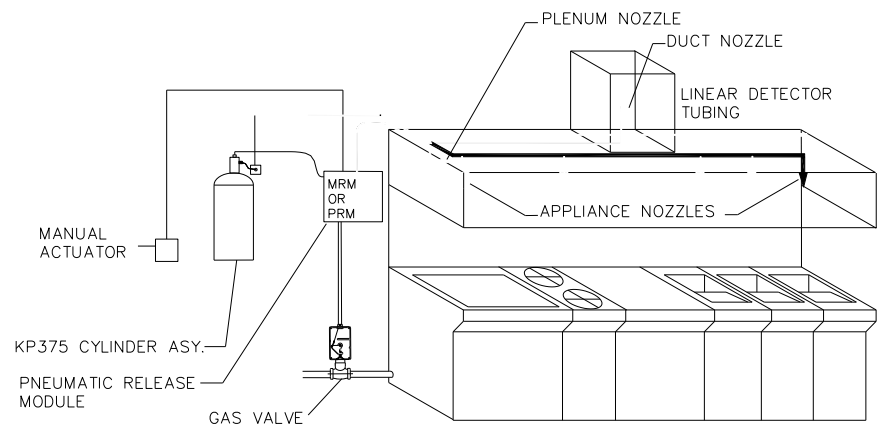

A Nozzle Branch Line is the distribution piping that runs from the supply branch tee splitting to the nozzles including all fittings used to exit the supply branch line.

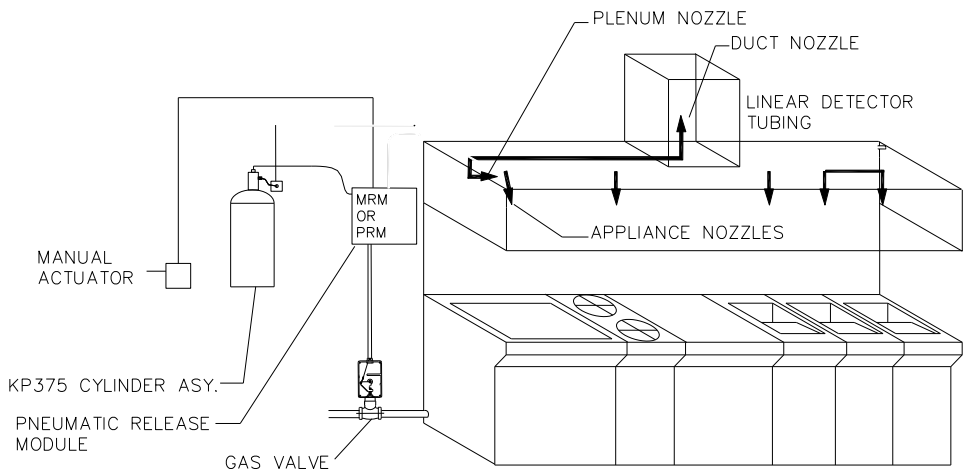

GENERAL PIPING REQUIREMENTS:

1. All pipe used for the distribution network must be schedule 40 (black, chrome or stainless steel) pipe.
2. Piping limitations are expressed in linear length of pipe. Linear piping is the actual length of straight pipe used throughout the system.

WARNING: GALVANIZED PIPE IS NOT ALLOWED

3. Maximum flow point per cylinder:
 - Model 275 = 8 flow points
 - Model 375 = 11 flow points
 - Model 475 = 14 flow points
 - Model 600 = 18 flow points
 - Twin 375 = 22 flow points

NOTE: THESE ARE EXAMPLES ONLY – OTHER CONFIGURATIONS CAN BE DESIGNED

TYPICAL KP DISTRIBUTION NETWORK FOR SINGLE 375 CYLINDER SYSTEM

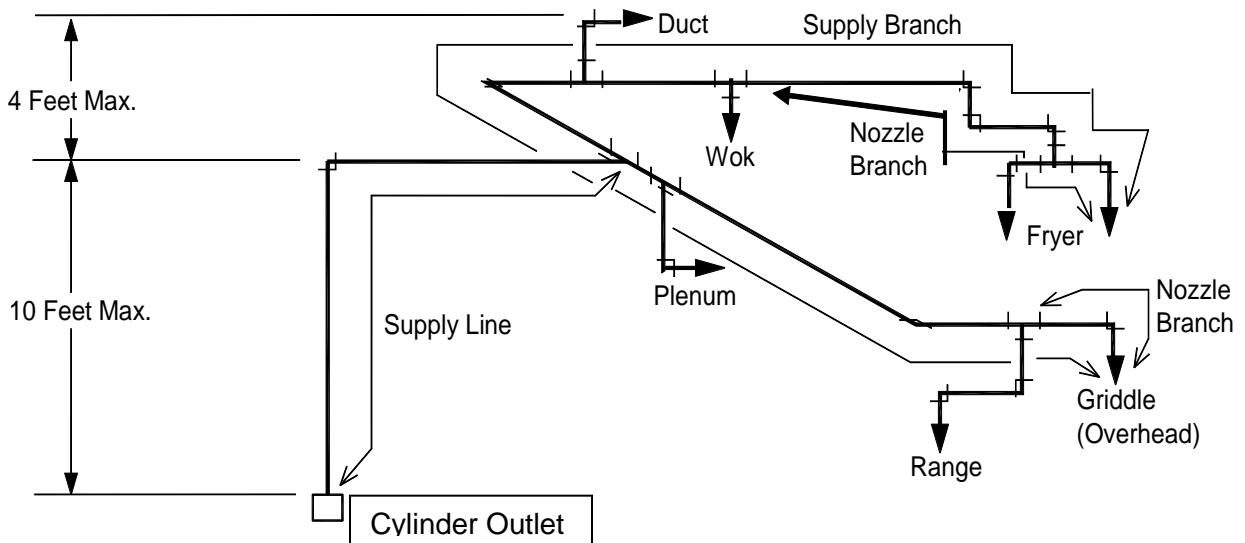
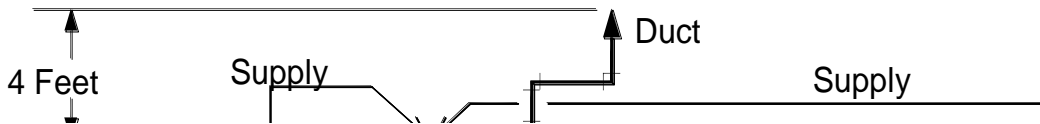
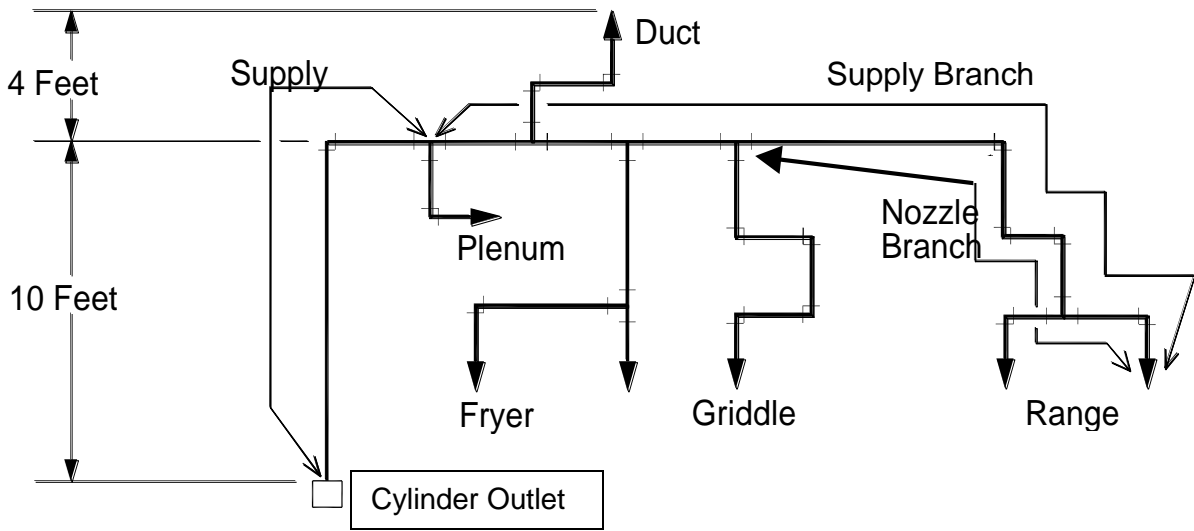

SPLIT PIPING SYSTEM

NOTE: The schematics above do not represent the only configurations possible – they are informational only.

TYPICAL KP DISTRIBUTION NETWORK FOR TWIN 375 CYLINDER SYSTEM

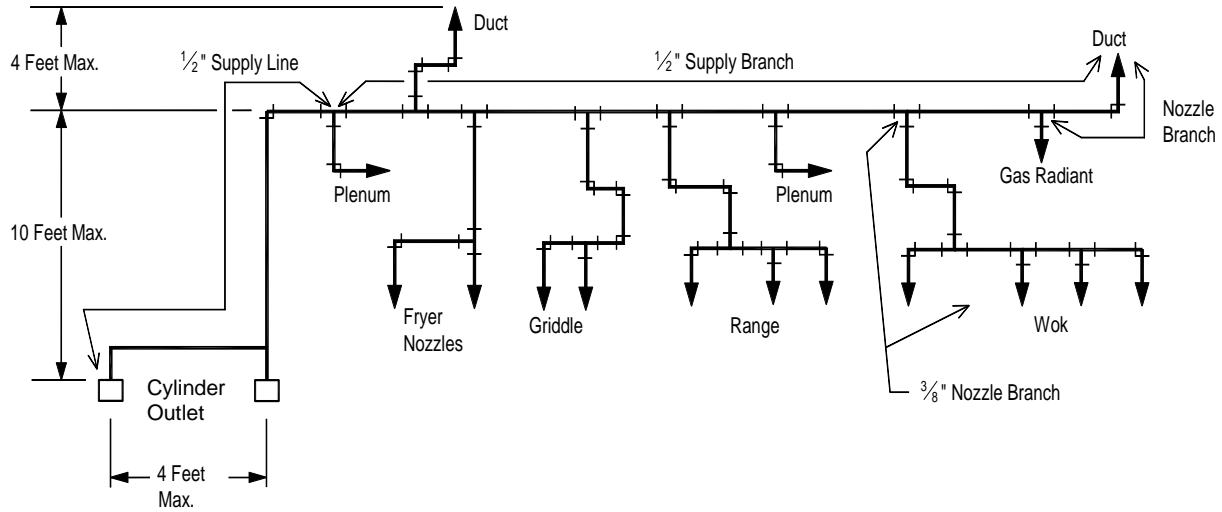

STRAIGHT PIPING SYSTEM

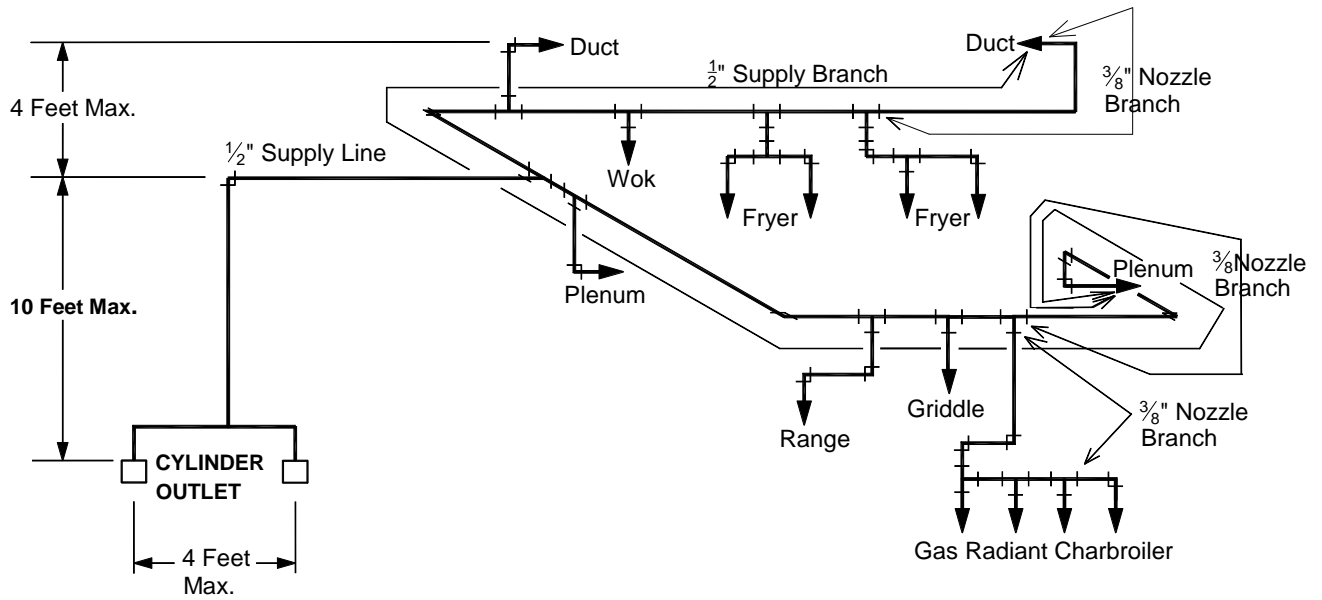

SPLIT PIPING SYSTEM

NOTE: The schematics above do not represent the only configurations possible – they are informational only.

**DISTRIBUTION PIPING LIMITS for KP FIRE SUPPRESSION SYSTEM ONLY
DESIGN LIMITS FOR ALL CYLINDER SIZES**

When designing a KP System to protect a kitchen containing a Fryer, Wok or Range, the following MINIMUM TOTAL SYSTEM PIPING must be used in accordance with the chart below:

MINIMUM PIPING REQUIREMENTS			
APPLIANCE	MINIMUM LINEAR FEET	MINIMUM TOTAL EQUIVALENT FEET	MINIMUM FLOW POINTS PER SYSTEM
Fryer	6.5	10	2
Wok	9	22.1	6
Range	7	16.4	4

SUPPLY LINE LIMITATIONS:

All pipe and fittings running from the distributor block or the discharge fitting to the first tee.

CYLINDER FLOW POINTS	PIPE SIZE	MAXIMUM LINEAR FEET OF PIPE	MAX. QTY. TEES	MAX. QTY. ELBOWS	MAX. QTY. BUSHINGS
275 - 8	3/8	20	1	5	0
375 - 11	3/8 OR 1/2	25	1	5	1
475 - 14	1/2	25	1	5	2
600 - 18	1/2	25	1	5	2
Two-375 – 22	1/2	30	2	7	2

- NOTE:** 1. Use 3/8" supply line only when all piping is to be 3/8" pipe.
2. The supply line has a maximum vertical rise above the distributor of 10 feet.

SUPPLY BRANCH LINE (including last nozzle branch) LIMITATIONS:

All pipe and fittings leaving the first splitting tee in the system and ending with the last nozzle in the last branch line. While the last nozzle branch is included in the piping limitations for the supply branch line, the limitation (pipe size and maximum length) for nozzle branch lines apply to this portion of the supply branch line.

CYLINDER FLOW POINTS	PIPE SIZE	MAX. FEET OF PIPE STRAIGHT	MAX. FEET OF PIPE SPLIT	MAX. QTY. TEES	MAX. QTY. ELBOWS	MAX. QTY. REDUCING BUSHINGS
275 - 8	3/8	20	25	7	8	0
375 - 11	3/8 OR 1/2	27	30	10	8	2
475 - 14	3/8	27	30	12	8	2
600 - 18	AS NOTED	35' OF 3/8" OR 1/2"	50' 3/8" PIPE ONLY	14	8	2
Two-375-22	AS NOTEED	40' of 1/2" (*30' of 3/8")	45 of 1/2" (*30' of 3/8")	18	8	0

- NOTE:** 1. In a single 3.75 Gallon Straight Pipe System, 5' of pipe may be transferred from the supply line to the supply branch line.
* 2. The use of 3/8" pipe with two manifold KP375s is only permitted when the **SUPPLY LINE** length is equal to or less than 20'.

NOZZLE BRANCH LINE LIMITATIONS:

All pipe and fittings leading from the supply branch tee to a system nozzle.

CYLINDER FLOW POINTS	PIPE SIZE	TOTAL LINEAR FEET OF PIPE	MAX. QTY. TEES	MAX. QTY. ELBOWS	MAX. QTY. BUSHINGS
275 - 8	3/8	32	5	10	0
375 - 11	3/8 OR 1/2	32	8	12	11
475 - 14	3/8	32	10	15	0
600 - 18	3/8	32	11	18	15
Two-375 - 22	3/8	32	18	18	20
MAX. PER NOZZLE BRANCH		7	3	6	4

See page 3-33A for General System Limitation.

GENERAL SYSTEM LIMITATIONS:

1. No ½" pipe nozzle branches less than 12" in length are allowed.
2. There is a maximum of (4) flow points on all nozzle branch lines.
3. The types of nozzles on a nozzle branch line may be mixed.
4. In the case of a system piping network having all single flow point nozzles, there shall be no nozzle branch line less than 12" in length.
Example: A piping network for a Model 275 Agent Cylinder has 8 single flow point nozzles. Therefore each nozzle branch line must be at least 12" long.
5. The cylinder discharge fitting, hose and distribution block are not included in the piping calculations.
6. If a flex distribution hose is used on a nozzle branch line, then 48" of piping shall be subtracted from the overall nozzle branch piping limitations.
7. Any fitting(s) associated with the installation of a flex distribution hose shall be counted against the overall nozzle branch piping limitations.
8. No mixing of pipe sizes within a piping category (supply line, supply branch line, nozzle branch line) is allowed. (i.e. one nozzle branch line is ½" pipe – all nozzle branches are to be 1/2" pipe.
9. ½" pipe for nozzle branches is allowed only in an (11) flow point system.
10. The maximum allowable vertical rise of pipe above the supply branch line for any duct nozzle branch is 4 feet (122 cm).

SPOT DETECTION NETWORK LIMITATIONS: MRM & MRM II

Optimum fire suppression system performance relies on proper detection network design. This section discusses the type of detectors used, their selection, and placement and design limitations.

The Amerex Restaurant Fire Suppression System MRM & MRM II uses a continuous cable, corner pulleys, detector bracket, detector linkage, fusible links, conduit offset, terminal link connector and a temperature-measuring device.

The quantity of detectors to be used in a system will depend on the number of ducts, number of appliances and the location of the appliances under the hood.

DETERMINING SPOT DETECTOR LOCATION AND NUMBER OF DETECTORS

In order to detect a fire in the duct, a detector is required to be placed within the duct opening or up to 12 inches into the duct. If it is mounted into the duct, the bracket shall not shield the fusible link from the hot vapors moving through the duct.

Every appliance under the hood that is being protected by the suppression system must have a detector placed over it and positioned within the path of exhaust vapors.

WARNING: DO NOT LOCATE DETECTORS DIRECTLY IN THE PATH OF GAS APPLIANCE EXHAUST FLUE GASES. DOING SO COULD RESULT IN UNNECESSARY DISCHARGE OF THE SYSTEM.

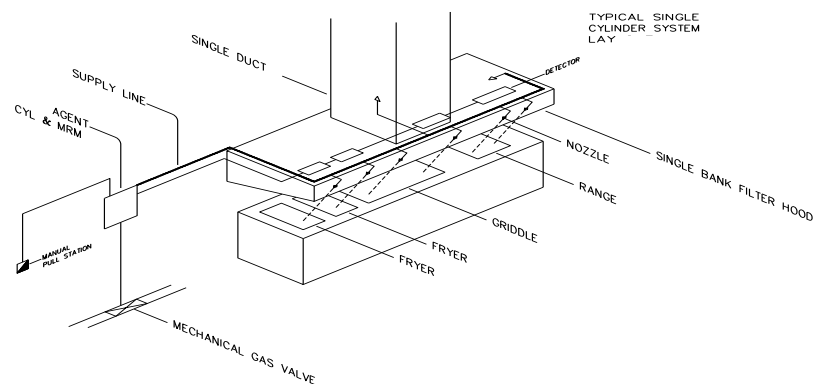

GENERAL LIMITATIONS OF DETECTION NETWORK:

Maximum of 30 corner pulleys. (either style)

Maximum of 30 detectors (any combination of temperature settings).

Maximum of 200 feet of cable on the detection network.

No pulley tees are allowed.

Remote manual pulls are not allowed on the detection network.

Maximum of 1 conduit offset (must be located at mechanical release module when chosen).

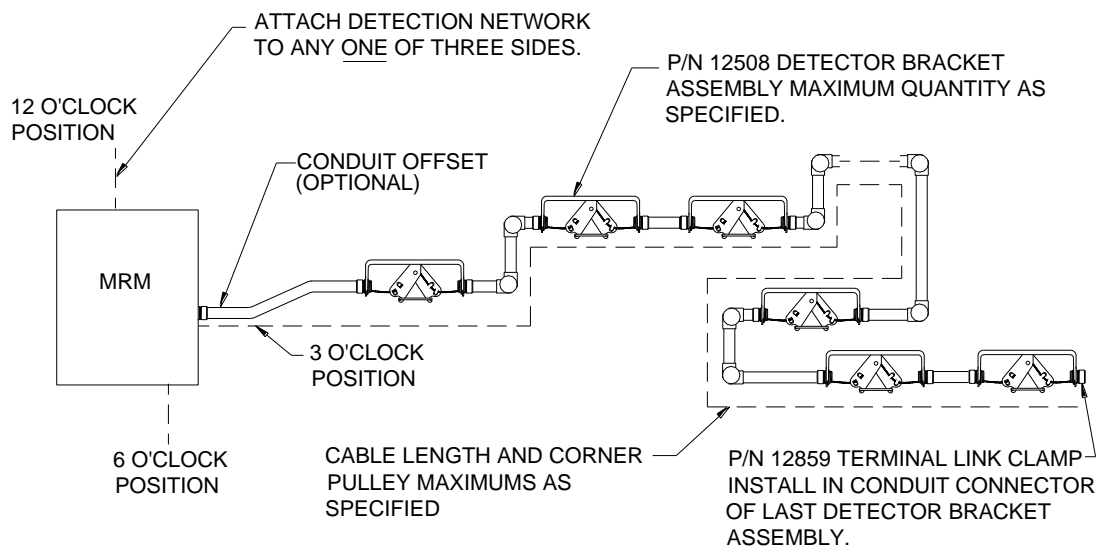

LINEAR FUSIBLE LINK DETECTION NETWORK OF SPOT DETECTORS

The standard spot detection system may be installed in a manner that will yield linear detection for the entire length of the hood without concern for where the appliance is located under the hood.

Why would I use this method over the lanyard linear fusible link system?

1. You want linear detection for the full length of hood but the limit of twenty links is not enough for the length of hood being protected.
2. You are protecting two hood and they are back to back, the lanyard system must be installed in a straight line.
3. You have two hoods that are end to end but one of the hoods only has one appliance requiring protection. The lanyard system is used for total linear detection of the entire hood. This version of detection allows you to use total linear hood detection on one hood and spot detection on the second hood.

This is accomplished by installing the link brackets so that there is a link no more than 24" from each end of the hood and no more than 24" between each successive link center. You must locate one link in the hood / duct opening.

The limitations on the amount of cable and links that can be used in the system are the same as that for the standard spot detection system.

- Limitations:
- Maximum of 30 corner pulleys. (Either style)
 - Maximum of 30 detectors (any combination of temperature settings)
 - Maximum of 200 feet of cable in the detection network.
 - No Tee Pulleys are allowed
 - Remote manual pulls are not allowed on the detection network.
 - Maximum of 1 conduit offset (must be located at the Mechanical Release Module)

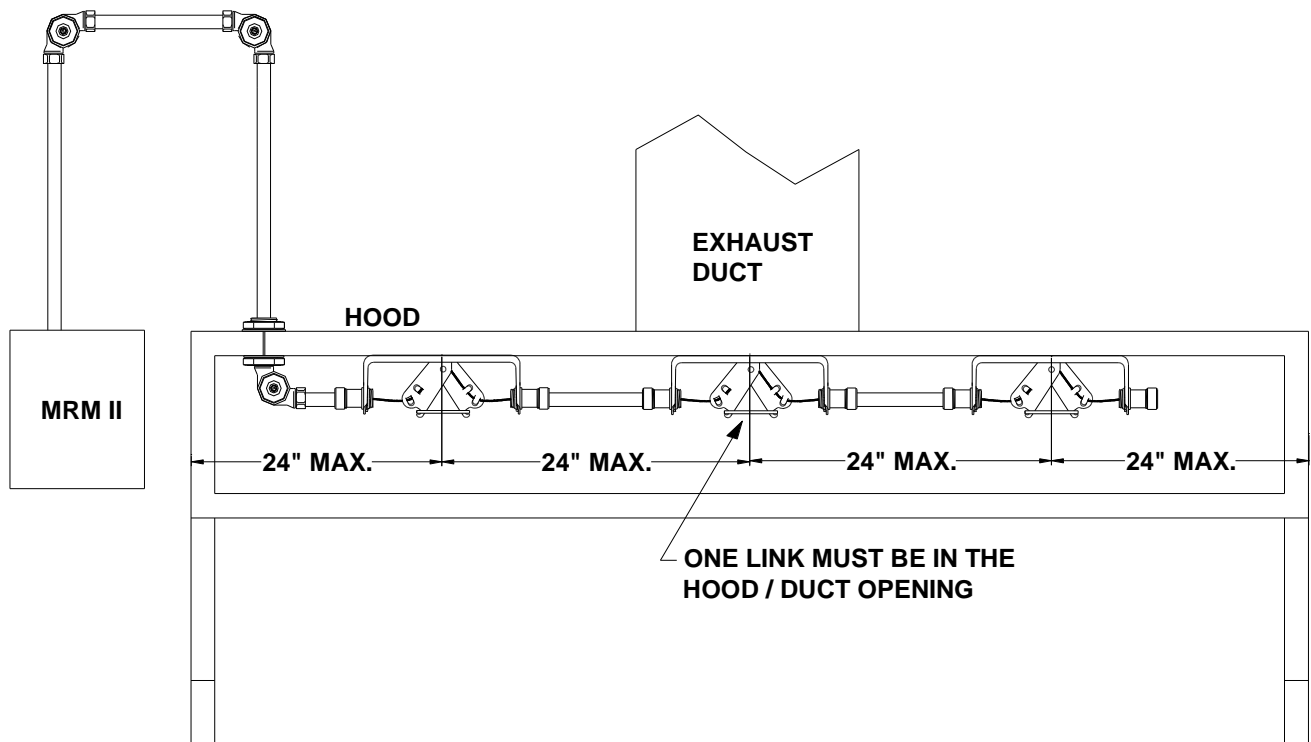

LINEAR FUSIBLE LINK DETECTION NETWORK – LANYARD SYSTEM

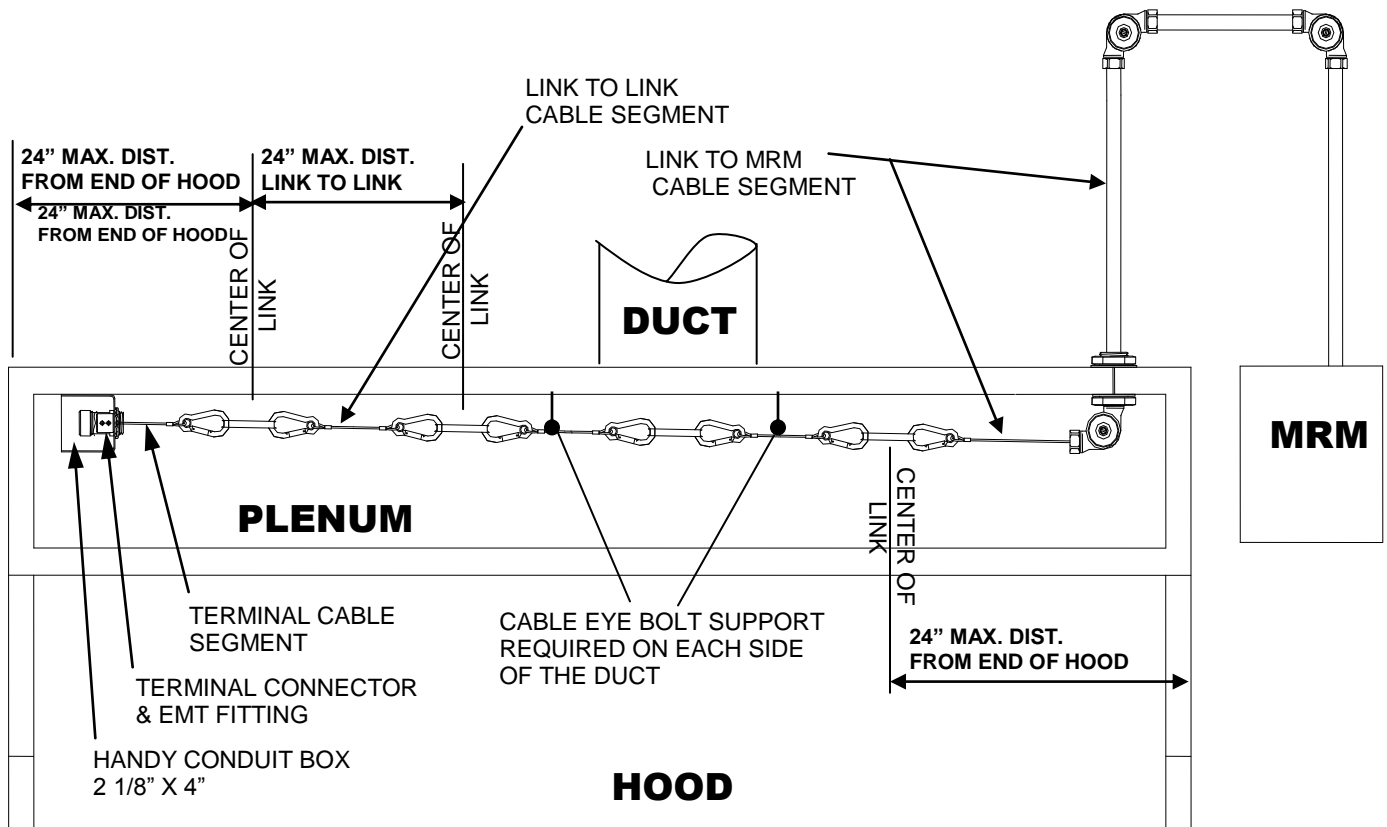

The Linear Fusible Link Detection System provides complete hood fire detection by placing thermal links at maximum 24" intervals the entire length of the hood. Installing the links in this manner allows the appliances to be placed anywhere under the hood without having to locate links directly over each appliance.

A unique system of cable segments, pre-fabricated, has been developed to make the installation of this system simple and easy. It eliminates the use of conduit, link holders and mounting brackets under the hood in the plenum area.

The limitations of the Linear Fusible Link Detection System are as follows:

1. Maximum of 20 detection links and (19) Link to Link Cable Segments.
2. Maximum of 30 feet of cable used in the Link to MRM Cable Segment.
3. Maximum of 20 corner pulleys. (either style)
4. Maximum unsupported detection cable length is 8'-0".
5. Refer to Fusible Link Selection section, page 3-24 of this manual for proper selection process. The higher setting links are to be used when higher temperatures are encountered with appliances such as char-broilers.
6. The Linear Fusible Link Detection System is for use in single hood applications, or where multiple hoods are connected "end to end" only. It cannot be used for "back to back" hood arrangements or multiple hoods that are mounted in separate locations and are part of a single Restaurant Fire Suppression System.

FUSIBLE LINK SELECTION

To assure that the appropriate temperature is selected, the temperature sensing device must be used at each detector location while the cooking line and exhaust fan is operating. Temperatures found at each detector should be recorded and placed with other documentation in the job file for future reference. Selection of fusible links should be made according to the temperature measured:

Globe Type "K" Standard Response

Temperature Measured	Link Rated Temp.	Part No.
70° to 150°F (21° to 65°C)	212°F (100°C)	12326
151° to 225°F (66° to 107°C)	280°F (138°C)	12327
226° to 300°F (21° to 65°C)	360°F (182°C)	12328
301° to 375°F (21° to 65°C)	450°F (232°C)	12329
376° (192°C) & above	Consult factory	Consult factory

Job Quick Response Links

Temperature Measured	Link Rated Temperature	Job Link Part Number
70° to 150°F (21° to 65°C)	200°F (93°C) Quick Response	16225
151° to 225°F (66° to 107°C)	286°F (141°C) Quick Response	16226
226° to 300°F (108° to 149°C)	360°F (182°C) Quick Response	16227

DETECTION NETWORK LIMITATIONS: PRM

Select a suitable location for the pneumatic release module (PRM) that has access for installation, service, recharge and where both the nitrogen actuation cylinder pressure gauge and the system status indicator can be viewed. The PRM has provisions for a single, continuous section of detection tubing. **“No Splicing” and “No Tee’s” are allowed.** There shall be only two tubing terminations – one at the accumulator cylinder inside the PRM and the other at the opposite end of the tubing, with the use of an End of Line fitting (P/N 16506). Install in areas where the Maximum Sustained Ambient Temperature does not exceed 176°F (80°C) and the Maximum Intermittent Safe Exposure Temperature is 375°F (190.5°C).

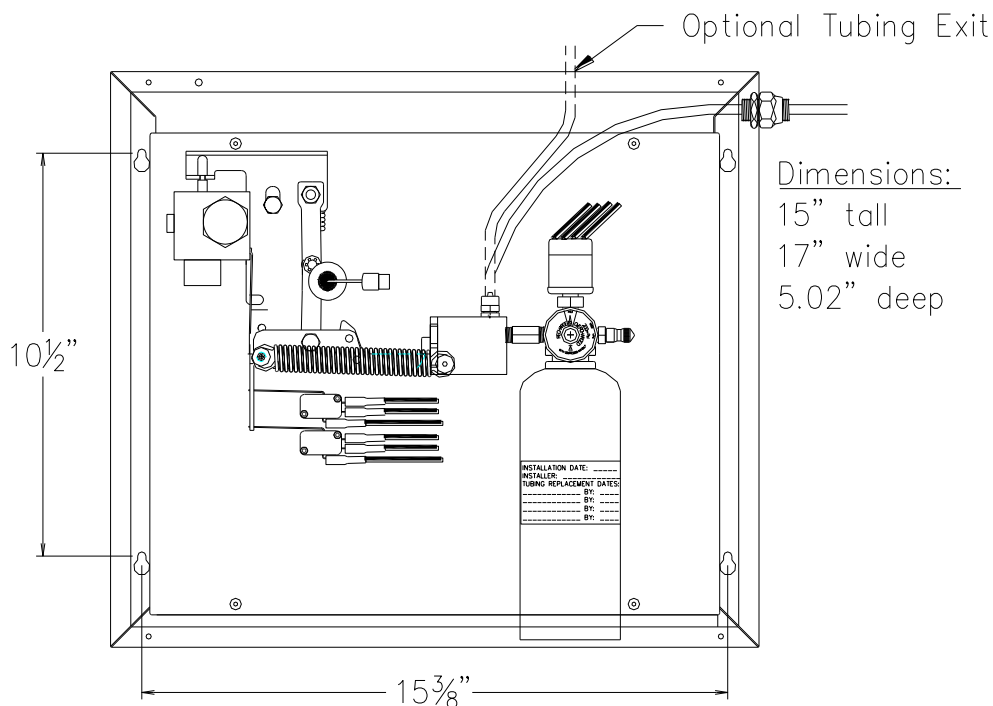

SEE SECTION 4 "INSTALLATION" FOR ROUTING INFORMATION ON DETECTOR TUBING PAGE 4-5

MANUAL PULL STATION NETWORK LIMITATIONS

Every Amerex Restaurant Fire Suppression System installation must have at least one manual pull station. The manual pull station network consists of cable, corner pulleys, pulley tee, manual pull station(s) and optional conduit offset.

GENERAL LIMITATIONS OF MANUAL PULL STATION NETWORK

- Maximum of 20 corner pulleys per manual pull station
- Maximum of 130 feet of cable per manual pull station
- Maximum of 1 pulley tee per network (counts as one corner pulley for each manual pull station)
- Maximum of 1 conduit offset per network (must be attached to the MRM and before tee pulley when chosen)

NOTE: Manual pull stations should be installed no higher than 48 inches from the floor and must be along a path of egress. Consult the local Authority Having Jurisdiction (AHJ) for the final approval for manual pull station quantity, locations and mounting height and other considerations prior to finalizing manual pull station mounting details.

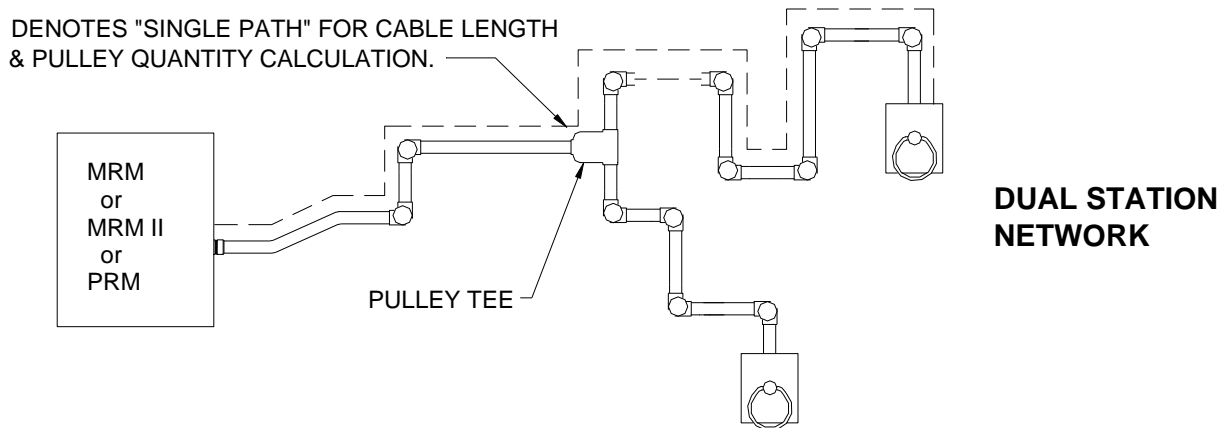
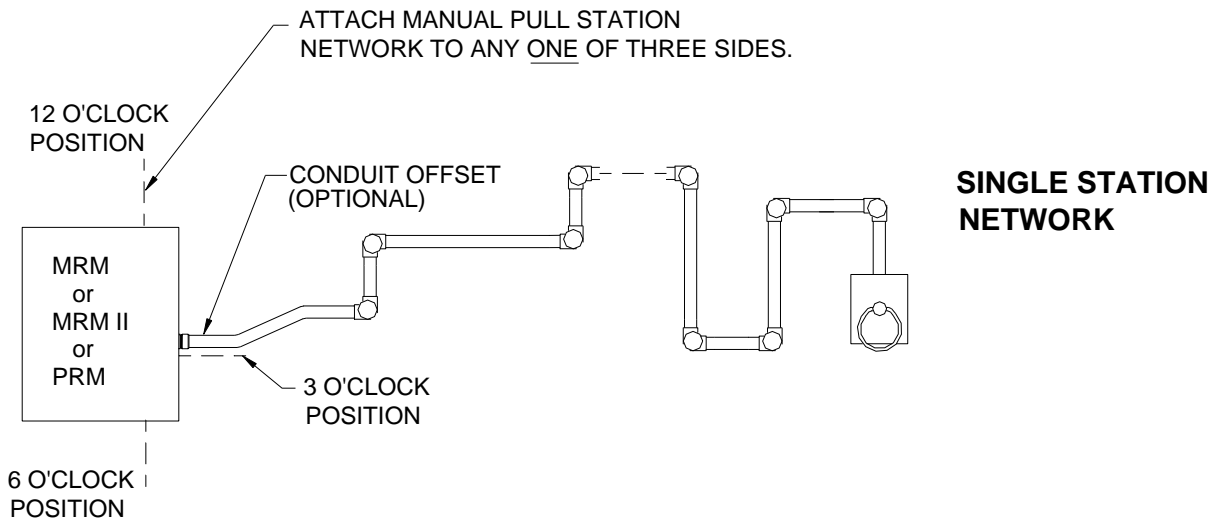

NOTE: The manual pull station(s) are the only MANUAL means of activating the Amerex Restaurant Fire Suppression System.

Dual MRM Installations Protecting a Single Hazard:

Certain circumstances may require additional link line capability, detectors, or manual pull stations to protect a single hazard. Examples would include multiple hoods in close proximity to one another (or interconnected). It is possible to install two MRM's to protect such hazards as a single hazard zone.

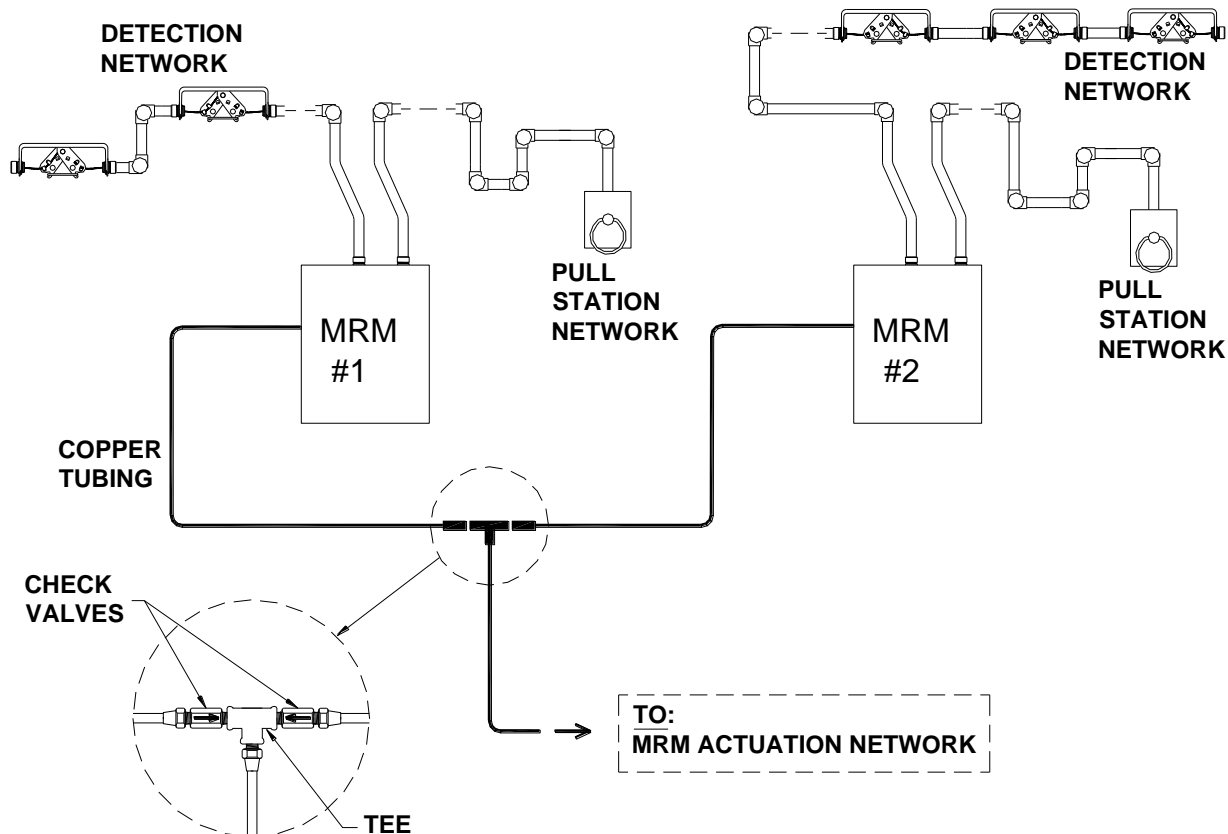

Note: Ensure that the arrows on the PN 10262 Check Valves are pointed into the Tee, as shown above. Use only two Check Valves, oriented at the Tee, as shown. The purpose of the Check Valves is to prevent one MRM from back-pressurizing the MRM that does not trip.

Limitations:

- 1) Adhere to the MRM actuation limitations as given on pages 3-29, 3-34 thru 3-36 & 3-39. The maximum length of tubing from the MRM to the last Agent Cylinder is determined as the direct single path from **each** MRM through the Tee.
- 2) Detection Networks are to remain independent from MRM #1 to MRM #2, and must adhere to previously stated limitations.
- 3) Manual Pull Networks are to remain independent from MRM #1 to MRM #2, and must adhere to previously stated limitations.
- 4) There is no Mechanical Gas Valve function with this installation option. Gas Valve closure is to be accomplished via a Manual Reset Relay and an Electric Gas Shut-off Valve
- 5) Any electrical function must be wired in either series (Normally-Closed function) or in parallel (Normally-Open function) through a micro-switch in **each** MRM. This will ensure that the firing of either MRM will facilitate the required function.
- 6) A clearly visible sign or placard must be placed securely adjacent to each of the two MRMs with the wording similar to the following:

“This Releasing Control Head is One of Two Units. Both Units Must be Serviced Together, in Conjunction with the Fire Suppression System”.

Warning: All Electrical Field Wiring should be performed by a Licensed Electrician per NFPA 70.

MECHANICAL GAS VALVE APPLICATIONS

The MRM, MRM II or PRM closes the mechanical gas valve immediately upon system discharge. A pneumatic and mechanical action in the gas trip assembly pulls on a cable attached to the mechanical gas valve, unlatching the valve and allowing an internal spring within the gas valve body to provide the closing force. Connection of the cable from the gas valve to the MRM, MRM II or PRM under tension maintains the gas valve in an open position.

MECHANICAL GAS VALVE

A mechanical gas valve trip assembly must be used with any mechanical gas valve. The gas valve trip assembly (P/N 12740) is included with all Amerex manufactured gas valves but must be ordered separately for use with gas valves listed in this manual supplied by other manufacturers.

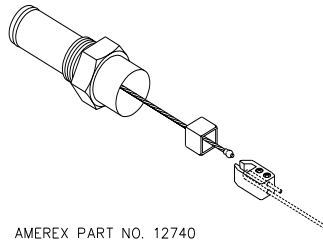

AMEREX PART NO. 12740

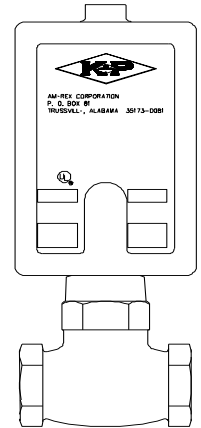

See Section 3 “System Components” for all mechanical gas valves that are suitable for use with the Amerex Restaurant Fire Suppression System. The use of any other mechanical gas valves will void the UL listing for the system installation. All of the listed valves have female NPT threads. The location of the gas valve should be accessible and approved by the local Authority Having Jurisdiction. A contractor licensed and qualified for such work should perform installation of the mechanical gas valve into the gas line.

MECHANICAL GAS VALVE ACTUATION NETWORK LIMITATIONS

The mechanical gas valve actuation network consists of cable, corner pulleys, pulley tee, gas valve and conduit offset.

GENERAL LIMITATIONS OF MECHANICAL VALVE NETWORK

- Maximum of 20 corner pulleys per mechanical gas valve of any listed type in KP Manual
- Maximum of 130 feet (39.6m) of cable per mechanical gas valve of any listed type in KP Manual
- Maximum of 1 pulley tee per network (counts as one corner pulley for each mechanical gas valve)
- Maximum of 1 conduit offset per network (must be located at the releasing module and before the tee pulley when used)

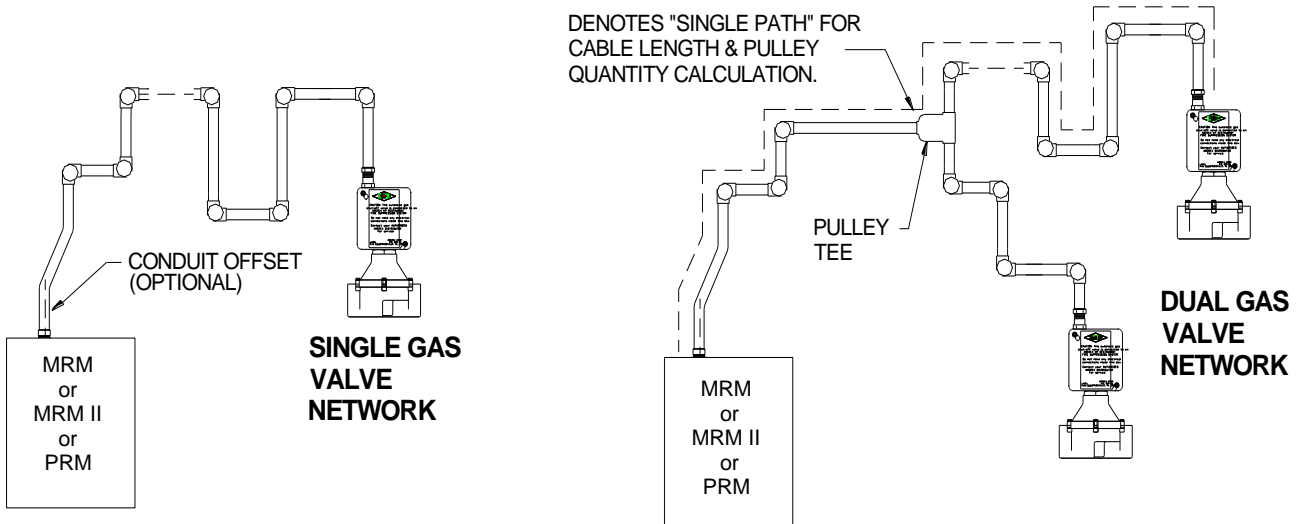

ELECTRICAL GAS VALVE APPLICATIONS

110 VAC electrical gas valves may be used in place of the mechanical gas valves. The electric shut-off valve used with the Amerex Restaurant Fire Suppression System must be UL listed for use with natural gas or propane, be held open by energizing an electric solenoid and be wired through a snap action switch and manual release relay. A qualified electrician must do any field wiring and connections involving the shut-down of electrical cooking equipment or an electric gas valve.

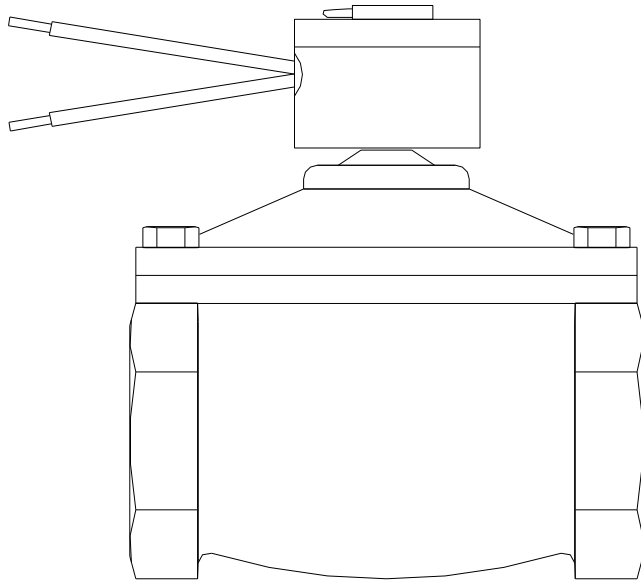

P/N	Size	Manufacturer
12870	3/4"	Asco
12871	1"	
12872	1 1/4"	
12873	1 1/2"	
12874	2"	
12875	2 1/2"	
12876	3"	

ELECTRIC GAS VALVE OPERATION

Power to the electric gas valve is run through the normally closed contact on a micro-switch located in the Pneumatic Release Module (PRM) or Mechanical Release Module (MRM & MRM II) to the Manual Reset Relay and from the Manual Reset Relay to the electric gas valve. In a normal (non fire) condition, current is allowed to flow to the solenoid on the electric gas valve, holding the valve open. In a fire condition, when the release module actuates the suppression system, the micro-switch contacts will transfer, opening the normally closed contacts in the manual reset relay, interrupting current to the gas valve and cause it to close.

Resetting the MRM, MRM II or PRM and transferring the contacts back to a normal (normally closed) position will not cause the electrical gas valve to open. The manual reset relay must be reset before current will flow to the valve and cause it to open. A loss in electrical power, even temporary or momentary, will require someone to manually reset the relay before the electrical gas valve will open again.

NOTE: SEE WIRING SCHEMATIC ON THE NEXT PAGE – A WIRING SCHEMATIC IS PACKED WITH EACH MANUAL RESET RELAY.

WIRING DIAGRAM FOR THE MANUAL RESET RELAY

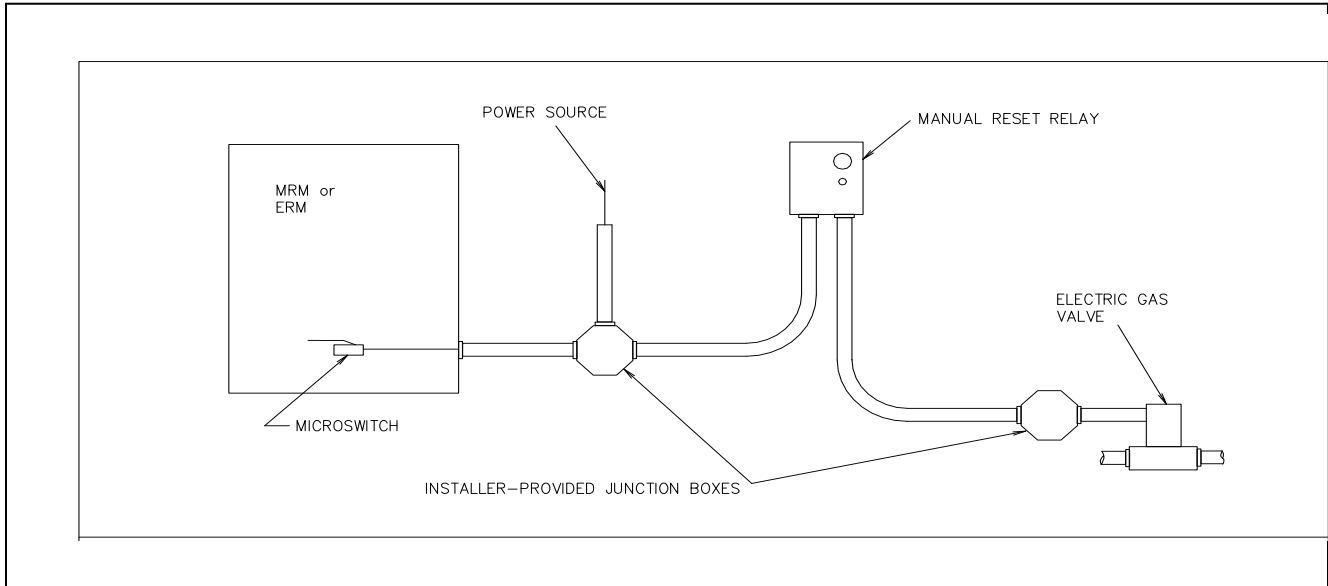

INTERNAL WIRING & EXTERNAL CONNECTIONS AS SHOWN (or equivalent):

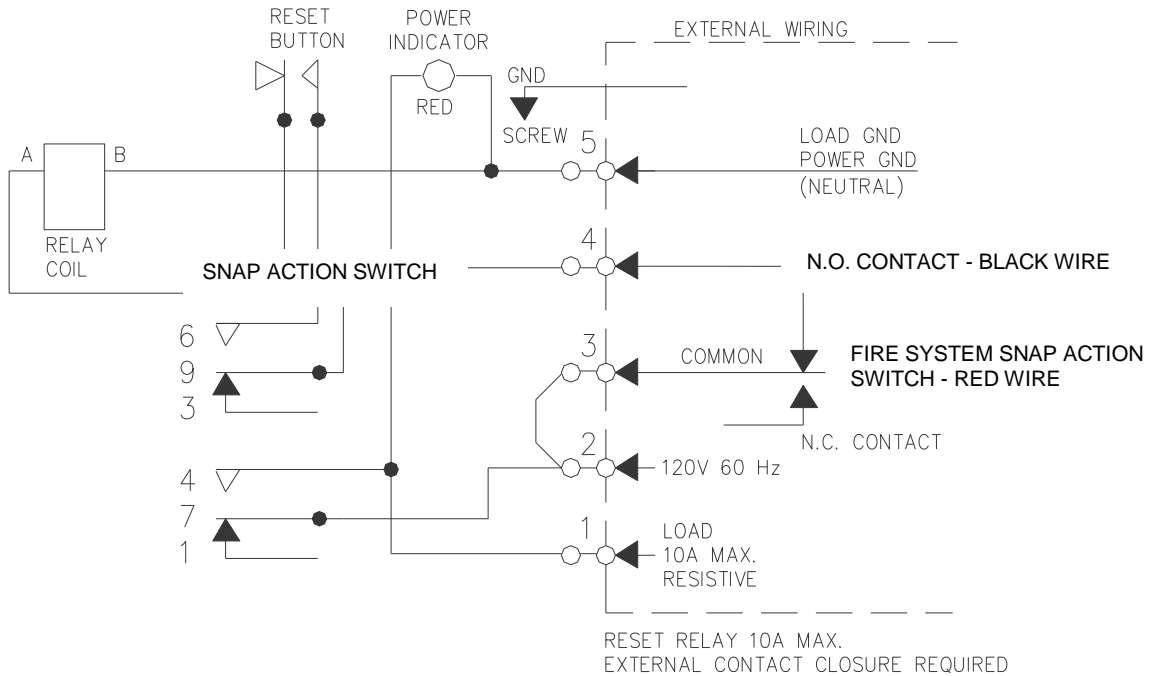

NOTE: DO NOT USE YELLOW WIRE ON SNAP ACTION SWITCH INSTALLATION. YELLOW WIRE IS TO BE USED ONLY FOR EXTRANEIOUS ALARM, LIGHT CIRCUITS, ETC.

SNAP ACTION SWITCH APPLICATIONS

One **Snap Action Switches, P/N 12524** is pre-installed in the Mechanical Release Module (MRM / MRM II) or Pneumatic Release Module (PRM). Up to a total of four snap action switches may be installed.

Part No.	Contacts	Rating
12524	SPDT	21 Amps 125, 250 or 277 VAC
	Single Pole	1 HP 125, 250 or 277 VAC
	Double Throw	2 HP 250, 277 VAC

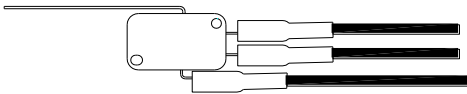

Red	Common	Non Alarm Condition
Yellow	N.O.	
Black	N.C.	

Snap Action Switches may be used to perform a variety of output functions such as sounding an auxiliary audible or visual alarm signaling device, sending a signal to an unsupervised building fire alarm system (a requirement per NFPA 96 if the building is equipped with a fire alarm system), shutting down electric cooking appliances, or disrupting power to an electrical gas valve.

WARNING: POWER TO COOKING APPLIANCES SHOULD NEVER BE RUN THROUGH THE SNAP ACTION SWITCH, THE SWITCH SHOULD BE USED TO OPERATE A SEPARATE, CONTRACTOR SUPPLIED, ELECTRICAL CONTACTOR OR MAGNETIC SWITCH OF SUFFICIENT RATING TO HANDLE THE POWER REQUIREMENTS OF THE ASSOCIATED COOKING APPLIANCES. A LICENSED ELECTRICIAN SHOULD PERFORM ALL ELECTRICAL FIELD WIRING.

WARNING: ELECTRICAL CONNECTIONS SHALL NOT BE MADE INSIDE THE MRM / MRM II OR PRM ENCLOSURE. ROUTE THE LEADS FROM THE SNAP ACTION SWITCH THROUGH THE APPROPRIATE KNOCK-OUT TO AN ATTACHED, LISTED ELECTRICAL JUNCTION BOX (DISTRIBUTOR SUPPLIED).

One alarm signaling **Snap Action Switch, P/N 18312**, is pre-installed in the MRM / MRM II / PRM and is to be used when the system is required to be electrically connected to a fire alarm system per NFPA 17 and NFPA 72 in a supervised, four-wire manner. It is designed to be mounted in the Mechanical Release Module (MRM / MRM II) and the Pneumatic Release Module (PRM) only for the purpose of initiating an alarm in a fire alarm system. All Snap Action Switch connections are to be made outside the MRM / MRM II / PRM in an approved junction box.

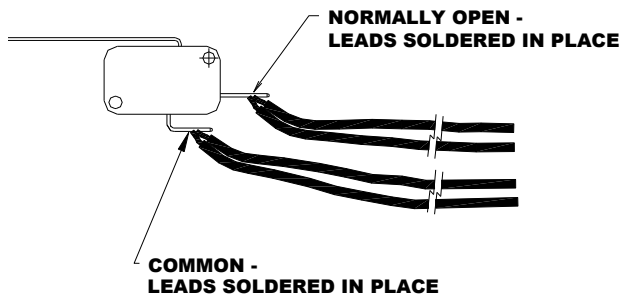

Part No.	Contacts	Rating
18312	SPST	0.25A, 30 VDC

ZONE DEFENSE DESIGN

THOSE INDIVIDUALS RESPONSIBLE FOR THE DESIGN & INSTALLATION OF THE AMEREX “ZONE DEFENSE” RESTAURANT FIRE SUPPRESSION SYSTEM MUST BE TRAINED BY AMEREX AND HOLD A CURRENT AMEREX CERTIFICATE OF TRAINING.

SYSTEM DESIGN

It is essential that any pre-engineered restaurant fire suppression system be properly designed, sized and installed. This section covers the design aspects unique to the Amerex “Zone Defense” Restaurant Fire Suppression System. The sketch below shows a typical Zone Defense System installed.

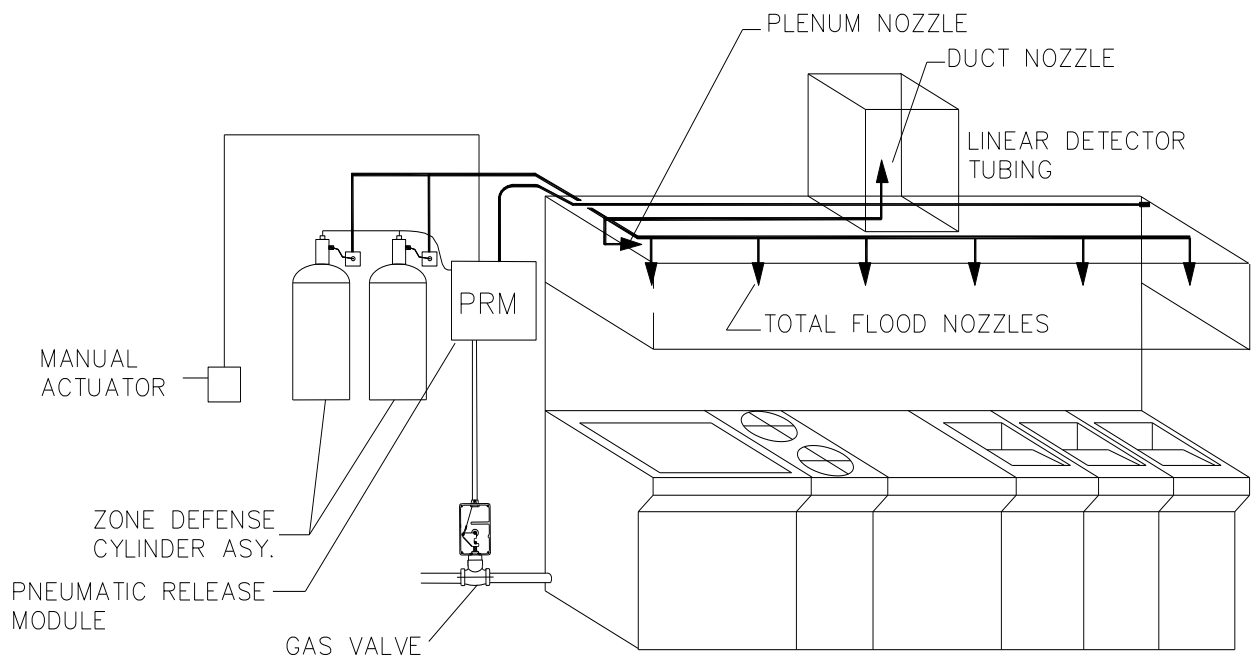

EXHAUST DUCT PROTECTION

The criteria for duct protection in a ZD System are the same as that for the KP System found in the first half of this section.

PLENUM PROTECTION

The criteria for plenum protection in a ZD System are the same as that for the KP System found in first half of this section.

DEDICATED APPLIANCE PROTECTION

When a ZD System includes protection for an appliance which **cannot** be protected by the ZD Nozzles creating the “zone of defense”, that appliance is to be protected using Dedicated Appliance Protection. The Dedicated Appliance Protection is found in the preceding portion of this section.

ZONE DEFENSE APPLIANCE PROTECTION

ZONE OF PROTECTION

NFPA 96 – 10.1.1: “Cooking equipment that produces grease-laden vapors and that might be a source of ignition of grease in the hood, grease removal device, or duct shall be protected by fire-extinguishing equipment.”

The Amerex “Zone Defense” Fire Suppression System has been approved and tested in compliance with the requirements of NFPA 96 – “Standard for Ventilation Control & Fire Protection of Commercial Cooking Operations, NFPA 17A – “Standard for Wet Chemical Extinguishing System” and UL-300 – “Fire Testing of Fire Extinguishing Systems for Protection of Restaurant Cooking Areas”. The Amerex “Zone Defense” System provides two types of appliance protection; “Zone of Protection” and “Dedicated Appliance Protection.” The following is a list of eligible cooking appliances and their maximum cooking hazard size that may be protected with the “zone of protection” nozzle coverage.

Appliance Type

Fryer
Range
Wok – maximum
Wok – minimum
Griddle
Lava Rock Char-broiler
Gas or Electric Radiant Char-broiler
Mesquite Charcoal (Solid Fuel) Char-broiler
Mesquite Chips & Chunks Char-broiler
Mesquite Logs Char-broiler

Maximum Cooking Hazard

34 in. deep x (5.6 Sq. Ft. total)
34 in. deep x Unlimited Length
26 in. Diameter x 7 in. Deep
14 in. Diameter x 4 in. Deep
30 in. deep x Unlimited Length
24 in. deep x Unlimited Length
24 in. deep x Unlimited Length
28.5 in. deep x Unlimited Length
(6 in. Maximum Fuel Depth)
28.5 in. deep x Unlimited Length
(6 in. Maximum Fuel Depth)
28.5 in. deep x Unlimited Length
(11 in. Maximum Fuel Depth)

ZONE OF PROTECTION – DEFINED

The “Zone of Protection” is a rectangular area 34” deep X the length of the hood in which an eligible cooking appliance can be placed and be protection. The appliance may be moved to any location within the “Zone of Protection” and be protected without any nozzles being moved or re-aimed.

The “Zone of Protection” is created by the use of overlapping spray from multiple nozzles creating an area that is soaked by wet chemical agent. This is accomplished by placing Amerex ZD nozzles, part number 14178, in a straight line from one end of the hood to the opposite end. The nozzles are to be a maximum of 20 inches (50.8cm) apart on center and must start and end at a point no greater than 6 inches (15.2cm) from the end of the hood. The nozzles are to be located 46 to 51 inches above the top surface of the appliances and aimed straight down. The resulting “Zone of Protection” is a rectangular area 34” (86.4cm) deep x length of hood with its front and rear edges 17” (43.2cm) from the centerline of the nozzles.

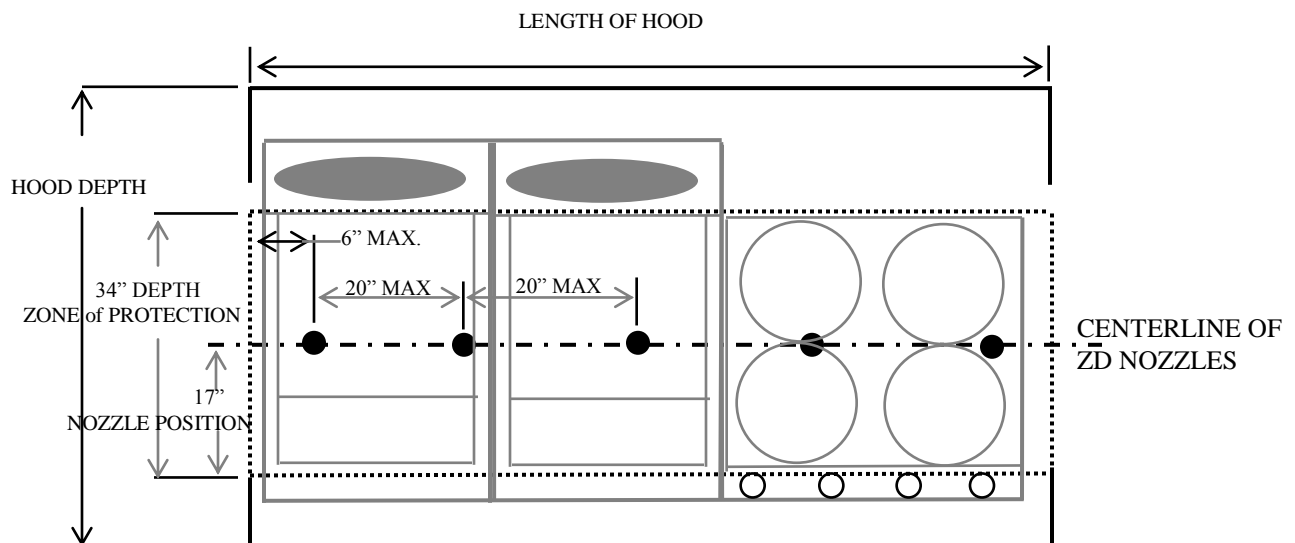

A **Supply Line** is the distribution piping that runs from the distributor outlet or discharge fitting to the first splitting tee.

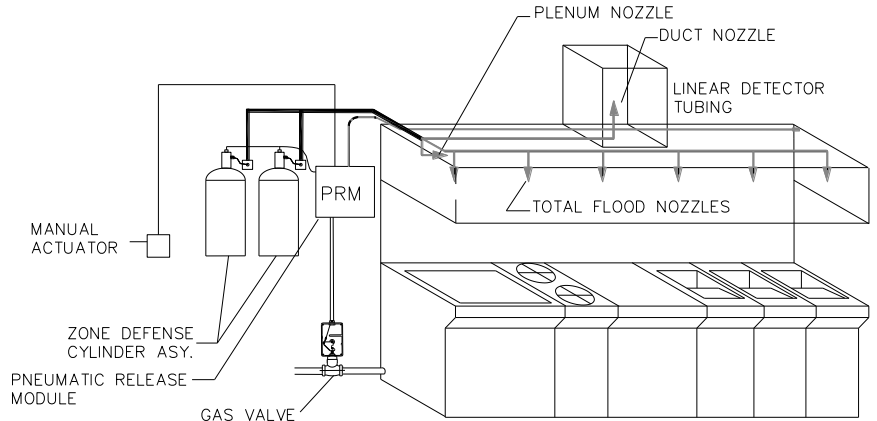

A **Supply Branch Line** (including the last nozzle branch) is the distribution piping that runs from the first splitting tee at the hood to the last nozzle in the system including all fittings used to exit the supply branch line.

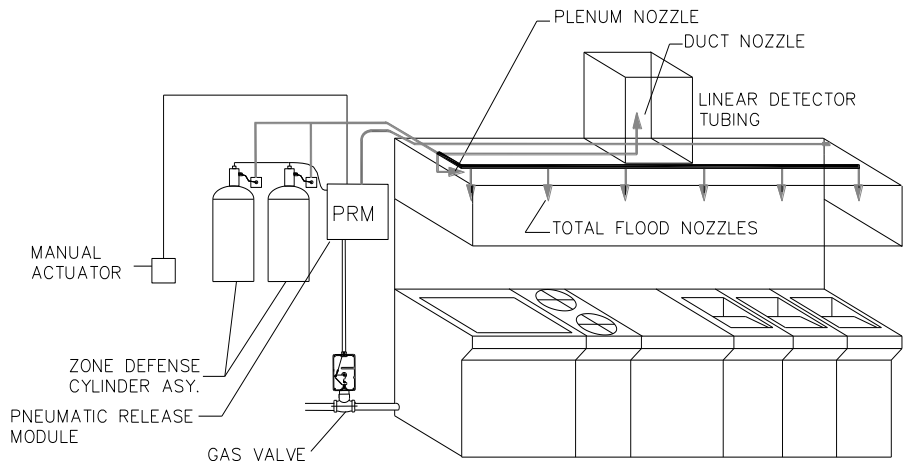

A **Nozzle Branch Line** is the distribution piping that runs from the supply branch tee or elbow to the nozzles including all fittings used to exit the supply branch line.

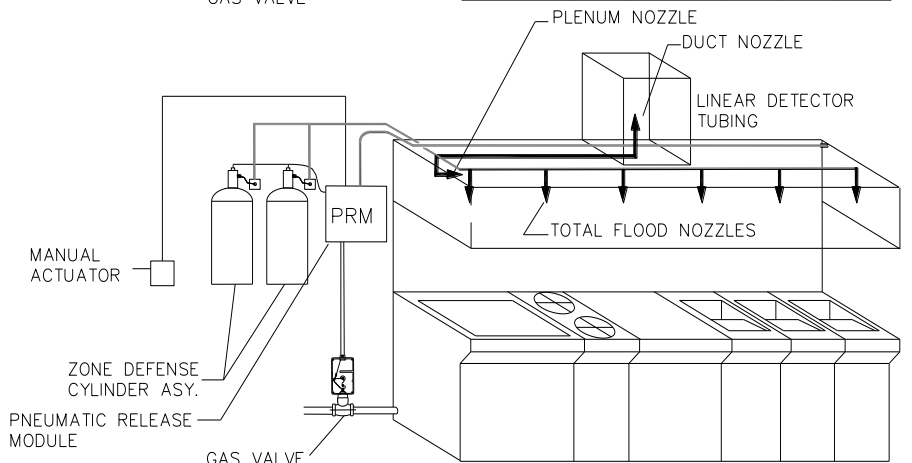

GENERAL PIPING REQUIREMENTS:

1. All pipe used for the distribution network must be schedule 40 (black, chrome or stainless steel) pipe. Stainless steel tubing for dedicated appliance protection branches is permitted in accordance with limitations on page 3-16.
2. Piping limitations are expressed in linear length of pipe. Linear piping is the actual length of straight pipe used throughout the system.

WARNING: GALVANIZED PIPE IS NOT ALLOWED

3. Maximum flow point per cylinder:
 - 275 = 8 flow points
 - 375 = 11 flow points
 - 475 = 14 flow points
 - Twin 375 = 22 flow points

NOTE: THESE ARE EXAMPLES ONLY – OTHER CONFIGURATIONS CAN BE DESIGNED

TYPICAL DISTRIBUTION NETWORK FOR ZD SINGLE 375 CYLINDER SYSTEM

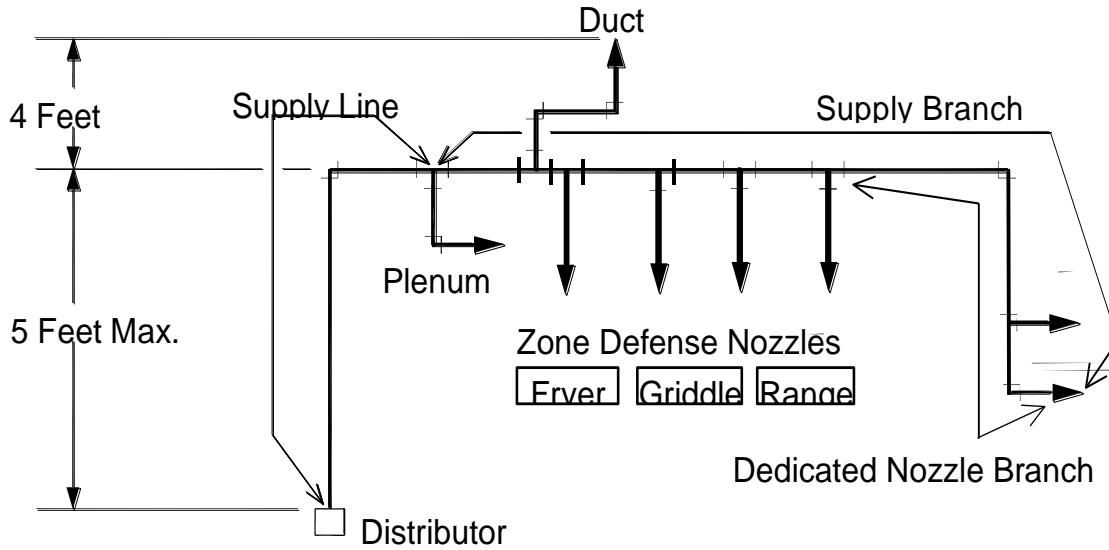

STRAIGHT PIPING SYSTEM

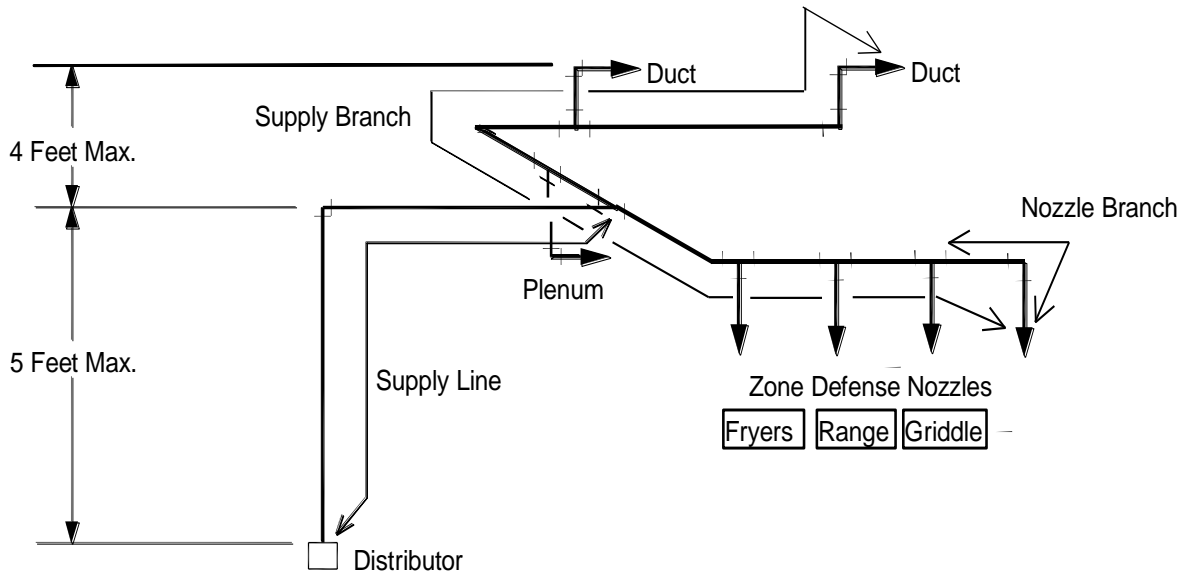

SPLIT PIPING SYSTEM

NOTE: The schematics above do not represent the only configurations possible – they are informational only.

TYPICAL DISTRIBUTION NETWORK FOR TWIN ZD CYLINDER SYSTEM

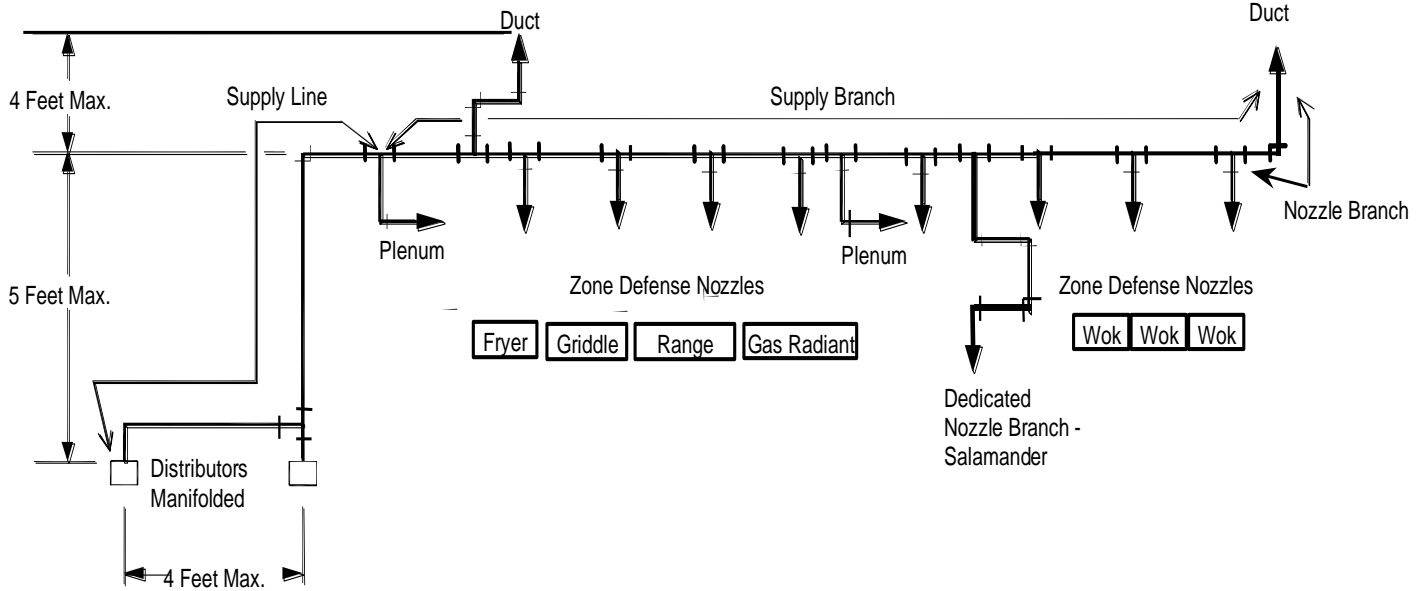

STRAIGHT PIPING SYSTEM

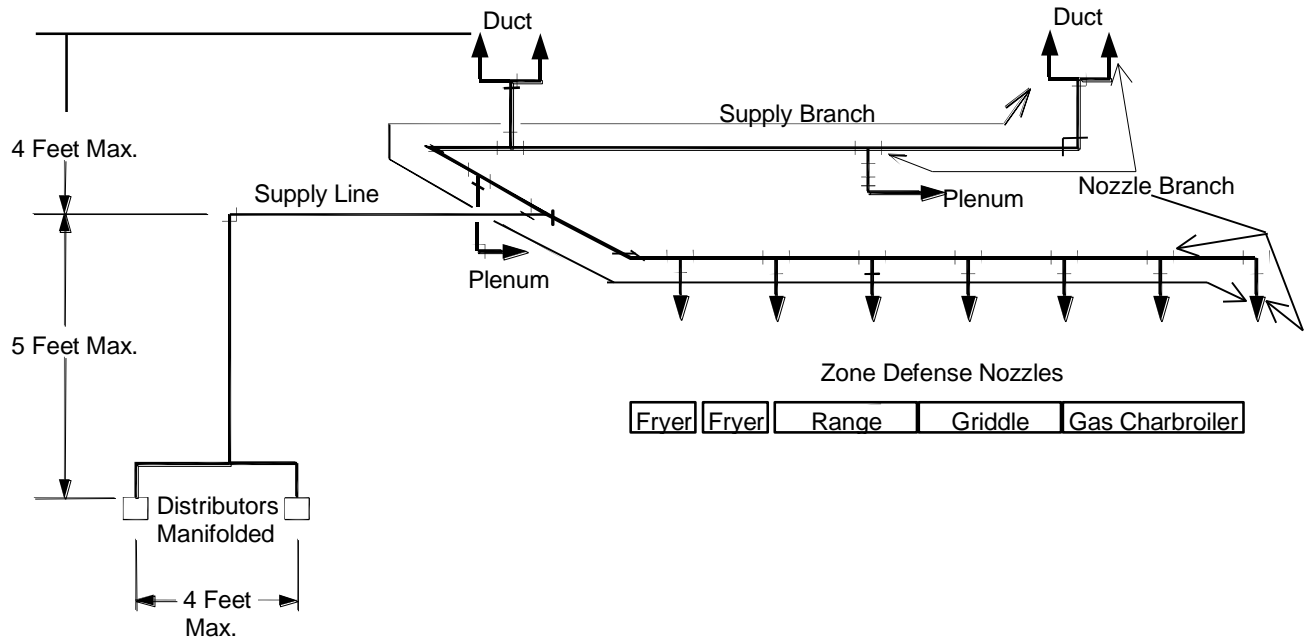

SPLIT PIPING SYSTEM

NOTE: The schematics above do not represent the only configurations possible – they are informational only.

ZD DISTRIBUTION PIPING DESIGN LIMITS FOR SINGLE CYLINDER OR TWIN CYLINDER MANIFOLDED SYSTEMS

When designing a "Zone Defense" system to protect a kitchen containing a Fryer, Wok or Range, the following **MINIMUM TOTAL SYSTEM PIPING** must be used in accordance with the chart below:

MINIMUM PIPING REQUIREMENTS			
APPLIANCE	MINIMUM LINEAR FEET	MINIMUM TOTAL EQUIVALENT FEET	MINIMUM FLOW POINTS PER SYSTEM
Fryer, Wok or Range	8'-2"	10	4

SUPPLY LINE LIMITATIONS:

All pipe and fittings running from the distributor block or the discharge fitting to the first splitting tee. (includes first tee)

CYLINDER FLOW POINTS	PIPE SIZE	MAXIMUM LINEAR FEET OF PIPE	MAX. QTY. TEES	MAX. QTY. ELBOWS	MAX. QTY. BUSHINGS
275 = 8	3/8	20	1	5	0
375 = 11	3/8	20	1	5	1
475 = 14	1/2	20	1	5	2
2-375 = 22	1/2	20	2	6	2

NOTE: 1. The supply line has a **maximum vertical rise** above the distributor of **5 feet**.

SUPPLY BRANCH LINE (including last nozzle branch) LIMITATIONS:

All pipe and fittings leaving the first/splitting tee in the system and ending with the last nozzle in the last branch line. While the last nozzle branch is included in the piping limitations for the supply branch line, the limitation (pipe size and maximum length) for nozzle branch lines apply to this portion of the supply branch line.

CYLINDER FLOW POINTS	PIPE SIZE	MAX. FEET OF PIPE STRAIGHT OR SPLIT	MAX. QTY. TEES	MAX. QTY. ELBOWS	MAX. QTY. REDUCING BUSHINGS
275 = 8	3/8"	20/25	7	8	0
375 = 11		22	6	8	2
475 = 14		27	12	8	2
2-375 = 22		32	14	9	2

NOZZLE BRANCH LINE LIMITATIONS:

All pipe and fittings leading from the supply branch tee to a system nozzle.

CYLINDER FLOW POINTS	PIPE SIZE	TOTAL LINEAR FEET OF PIPE	MAX. QTY. TEES	MAX. QTY. ELBOWS	MAX. FLOW POINTS PER BRANCH
275 = 8	3/8	32	5	10	
375 = 11		22	4	12	
475 = 14		32	10	15	
3-375 = 22		32	6	22	
TOTAL FLOOD NOZZLE BRANCH MAX.		3	0	6	2
DUCT NOZZLE BRANCH MAX.		6	2	4	3
DEDICATED NOZZLE BRANCH LINE		7	1	6	2

NOTE: 1. The Duct Nozzle Branch has a **maximum vertical rise** above the supply branch line of **4 feet**.

STAINLESS STEEL TUBING NOZZLE BRANCH LIMITATIONS:

All tubing and fittings leading from the supply branch tee to a dedicated appliance nozzle. One S.S. tubing nozzle branch is allowed per cylinder. Example: If two cylinders are manifold together, then the use of two S.S. tubing nozzle branches is permitted within that system.

MAX. FLOW POINTS PER BRANCH	PIPE SIZE	TOTAL LINEAR FEET OF PIPE	MAX. QTY. TEES	MAX. QTY. ELBOWS
2	3/8	10	1	6

- NOTE:**
1. The tubing is to be 3/8" O.D. x 0.335" I.D. x 0.02 Thk. Wall annealed Stainless Steel Type 304.
 2. The use of steel or stainless steel Bite-Seal compression fittings is required for use with S.S. tubing.
 3. No tube bending allowed.

GENERAL SYSTEM LIMITATIONS:

1. Nozzle types may not be mixed on any nozzle branch line.
2. The discharge fitting, distributor and distribution hose are not to be included in any calculations.
3. Duct nozzle has a **maximum vertical rise** above the supply branch line of **4'-0"**.
4. Maximum cylinder centerline to cylinder centerline distance for manifold cylinders is to be 4 feet.
5. The supply line has a **maximum vertical rise** above the distributor of **5 feet**.

DETECTION NETWORK LIMITATIONS:

PRM DETECTION

Optimum fire suppression system performance relies on proper detection network design. This section discusses the location, design and installation limitations.

The Amerex Zone Defense Fire Suppression System may use one of two detection methods. The first is a PRM that uses a continuous piece of pressurized thermal sensitive tubing to provide the ultimate in dependable fire detection. **No cable, No corner pulleys, No detector bracket, No link holders, No fusible links, No conduit offset, or terminal link connector** to install. Simply run the pressurized thermal sensitive tubing through the plenum of the hood and across the center of the hood duct opening. Fasten the tubing securely every 18 inches (45.7cm) and you have provided protection the entire length of the hood. No matter where the appliance is located under the hood, it is being watched by the PRM (Pneumatic Release Module).

In order to detect a fire in the duct, the tubing is required to be placed across the center of the hood / duct opening or three sides of the hood duct opening. See page 4-5 of the manual for tubing routing and see PRM Design & Installation Manual Part No. 16546, dated, March 2006, for installation instructions.

WARNING: DO NOT LOCATE TUBING DIRECTLY IN THE PATH OF GAS APPLIANCE EXHAUST FLUE GASES. DOING SO COULD RESULT IN AN UNNECESSARY DISCHARGE OF THE SYSTEM.

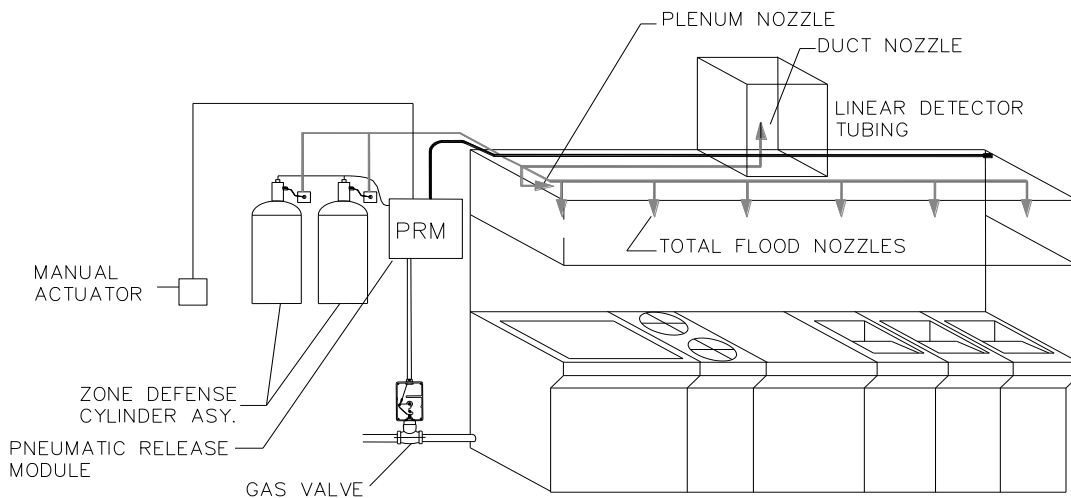

MRM & LINEAR FUSIBLE LINK DETECTION

The second detection method is the use of a MRM or MRM II in conjunction with the Linear Fusible Link Detection network. Due to the arrangement of the fusible links in the hood it is considered to cover the full length of the hood, no matter where the fire may occur. This system is explained in Section 3, page 3-35 & 3-36 of this manual.

SYSTEM INSTALLATION, TESTING, MAINTENANCE & RECHARGE

The installation of all components are outlined in Section 4, system testing is outlined in Section 5, system maintenance is outlined in Section 6 and reset / recharge are outlined in Section 7 of this manual.

SECTION 4

SYSTEM INSTALLATION

MANUAL P/N 20150

AMEREX

RESTAURANT

FIRE SUPPRESSION SYSTEM

Tested and Listed by
Underwriters Laboratories, Inc.
to UL Standard 300
EX 4658

Tested and Listed by
Underwriters Laboratories of Canada
to UL/ORD 1254.6-1995

December 2008

SYSTEM INSTALLATION

GENERAL:

Before starting the installation of a system, a complete analysis of the hazards, a system design and drawing of the proposed system layout shall be accomplished. The design, drawings and bill of materials shall be compared with conditions found at the jobsite and discrepancies noted before proceeding. Always contact the local AHJ (Authority Having Jurisdiction) for fire codes and Health Inspectors for special requirements in the specific area that the system is being installed.

Material such as pipe, fittings, EMT conduit, fasteners, mounting and securing hardware for pipe and conduit are not supplied by Amerex with the KP system. These items are chosen and supplied by the installer.

All components must be installed in an environment that does not exceed the systems temperature range listing of 32°F – 120°F (0°C – 49°C). All Agent Cylinder Models are to be installed in the vertical up-right position.

All system components – release module, cylinder assembly, mounting brackets, detectors, fusible links, pneumatic detection tubing, agent, nozzles, manual pull stations, gas shut off devices, corner pulleys, pulley tee, nitrogen cylinders, etc. – must be UL listed for use with the Amerex Restaurant Fire Suppression System. Use of components that are not listed for use in this system will void the warranty and may affect system performance.

INSTALLING THE 375 AGENT CYLINDER BRACKET (P/N 16085)

Choose an appropriate location for the agent cylinder assembly where the pressure gauge can be read, the cylinder safely accessed for recharge and service, is acceptable to the AHJ and has a sufficient structure to accept the weight. Using the bracket as a template, mark the top two holes for mounting, secure the bracket loosely with appropriate fasteners, adjust for level and plumb, mark the remaining holes and fasten securely. The bracket is equipped with a distributor to receive both the hose from the cylinder discharge outlet and the discharge piping. The distribution network piping can be installed without the agent cylinder assembly in the bracket. A minimum of three holes shall be used to mount the bracket in any situation. The two slotted holes and a hole in the center of the vertical strap shall be used.

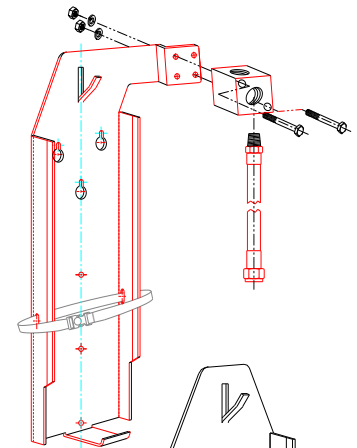

INSTALLING THE NEW 375 AGENT CYLINDER BRACKET (P/N 17690)

Choose an appropriate location for the agent cylinder assembly where the pressure gauge can be easily read and the cylinder safely accessed for recharge and service. The location should be acceptable to the AHJ and have sufficient structure to accept the weight of the agent cylinder. Using the bracket as a template, mark the top two holes for mounting, secure the bracket loosely with appropriate fasteners, adjust for level and plumb, mark the remaining holes and fasten securely. The distribution network piping is attached to the cylinder valve outlet via a swivel fitting. A minimum of three holes shall be used to mount the bracket in any situation. The two slotted holes and a hole in the center of the vertical strap shall be used.

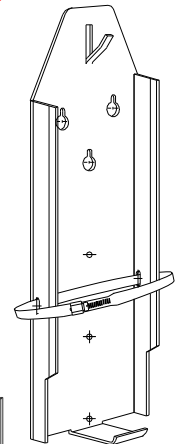

INSTALLING THE 275/375/475 AGENT CYLINDER BRACKET (P/N 16920)

Choose an appropriate location for the agent cylinder assembly where the pressure gauge can be read, the cylinder safely accessed for recharge and service, is acceptable to the AHJ and has a sufficient structure to accept the weight. Using the bracket as a template, mark the top hole, secure the bracket loosely with appropriate fasteners, adjust for level and plumb, mark the remaining holes and fasten securely.

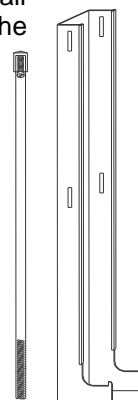

INSTALLING THE 375 AGENT CYLINDER ASSEMBLY (P/N 13334) TO P/N 16085 OR P/N 17690 BRACKET ASY.

Insert the cylinder onto the hanger to rest on the bottom support. Buckle up belly strap and tighten to aid in support. Insure proper fit of bracket to cylinder loop. Attach distribution piping to valve outlet via swivel adapter.

INSTALLING THE 275 / 375 / 475 AGENT CYLINDER ASSEMBLY (P/N 13334, 16921, or 17379) TO P/N 16920 BRACKET ASY.

Place the cylinder so that it rest on the bottom support of the bracket. Install stainless steel belly strap and tighten against the cylinder to aid in support. Attach distribution piping to swivel fitting and then tighten swivel to cylinder valve outlet.

INSTALLING THE MODEL 600 AGENT CYLINDER BRACKET (P/N 15166 - DISCONTINUED) (P/N 21583 - DISCONTINUED) (P/N 23184 – NEW)

Choose an appropriate location for the Agent Cylinder valve assembly where the pressure gauge can be read, the cylinder can be safely assessed for recharge and service, is acceptable to the AHJ and has sufficient structure to accept the weight. Using the bracket as a template, mark the mounting holes. Use at least three holes for mounting, secure the bracket loosely with appropriate fasteners, adjust for level and plumb and fasten securely. The bracket is supplied with a stainless steel strap to hold the cylinder against the back of the bracket. **A minimum of three holes, should be used to mount the bracket in any situation.**

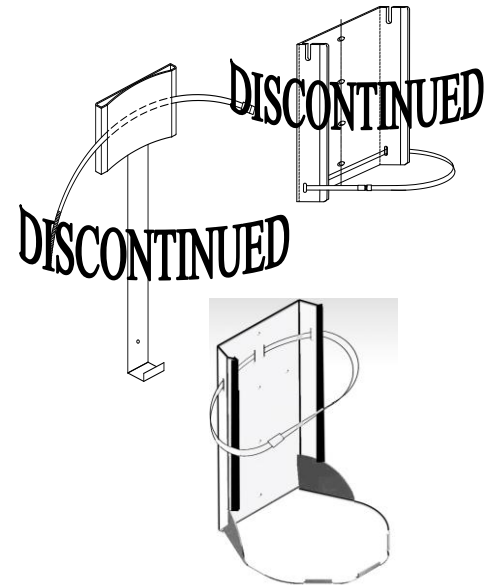
**INSTALLING THE MODEL 600 DISCHARGE FITTING KIT (P/N 10199)**

The discharge fitting kit consists of a brass fitting with an o-ring on one end and 3/4 NPT male threads on the other, and a stainless steel flange for locking the fitting in place. The discharge fitting should be inserted into the outlet of the agent cylinder outlet **carefully**, to insure that the o-ring is not damaged – the o-ring forms the seal between the cylinder and the discharge piping. The stainless steel flange is then bolted in place to secure the fitting to the valve outlet.

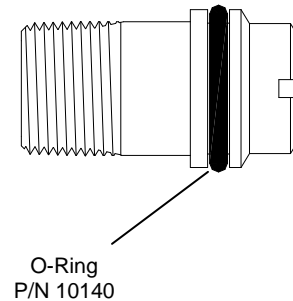
**INSTALLING THE MODEL 600 AGENT CYLINDER (P/N 15196) – DISCONTINUED CONFIGURATION**

The KP600 agent cylinder assembly is fitted with an attachment bracket that is a component welded to the cylinder assembly. The attachment bracket is used to attach the cylinder assembly to the cylinder mounting bracket. The cylinder attachment bracket fits easily into the upper slotted portion of the mounting bracket. Once inserted into the slot, it is locked in place by two notched areas in the attachment bracket. This will prevent cylinder movement from side to side. Once this is accomplished, the installer's hands are free to attach the stainless steel strap to secure the cylinder against the bracket.

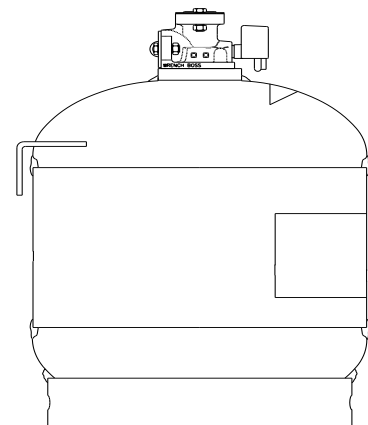

NOTE: BOTH THE SHIPPING PLATE AND THE ANTI-RECOIL PLATE MUST BE REMOVED AT THE TIME OF INSTALLATION.

INSTALLING THE MODEL 600 PNEUMATIC ACTUATOR (P/N10147)

A pneumatic actuator is required for every KP600 agent cylinder assembly. The actuator is bolted directly to the top of the agent cylinder discharge valve. When actuation occurs at the MRM or PRM, the pneumatic pressure from the nitrogen cylinder enters the actuator through $\frac{1}{4}$ " NPT threaded ports on either side. The actuation pressure forces the piston inside to extend and depress the valve stem of the discharge valve. The piston extends through a retainer plate and the ball plunger locks the piston in its extended position.

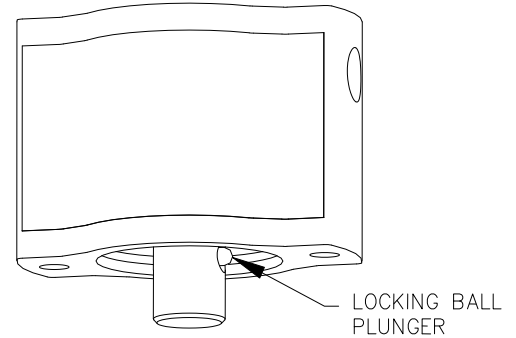

NOTE: WHEN INSTALLING ONLY ONE CYLINDER, THE ACTUATION LINE WOULD COME IN ON ONE SIDE OF THE ACTUATOR AND THE OTHER SIDE WOULD BE PLUGGED USING A $\frac{1}{4}$ " NPT BRASS PIPE PLUG. IF YOU ARE INSTALLING MORE THAN ONE CYLINDER THE SECOND PORT IS USED TO TRANSFER PRESSURE TO THE NEXT CYLINDER AND SO ON, UNTIL YOU REACH THE LAST CYLINDER AND THE OUTLET/TRANSFER PORT IS PLUGGED.

INSTALLING THE AGENT CYLINDER ENCLOSURE (P/N 16814) STAINLESS STEEL

The Cylinder enclosure (P/N16814) is designed to contain one Amerex 275 / 375 or 475 agent cylinder (P/N 16921, 13334 or 17379). The enclosure has been designed and tested to support the weight of the cylinder resting on the bottom of the enclosure. **NO MOUNTING BRACKET REQUIRED.** A swivel fitting, p/n 16901, is provided for attaching the piping network to the discharge outlet of the agent cylinder valve. Use an appropriate reducing bushing if $\frac{3}{8}$ " supply line pipe is used. Install as follows:

- 1) Locate and anchor the enclosure with appropriate fasteners using a minimum of four of the six available mounting holes, see hole spacing below.

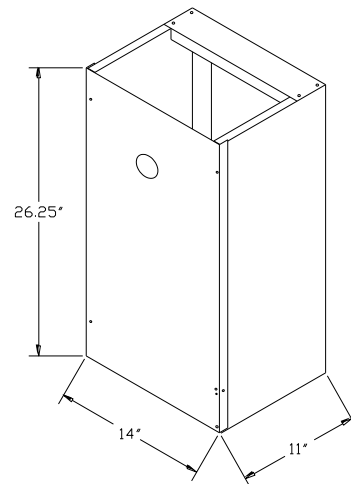
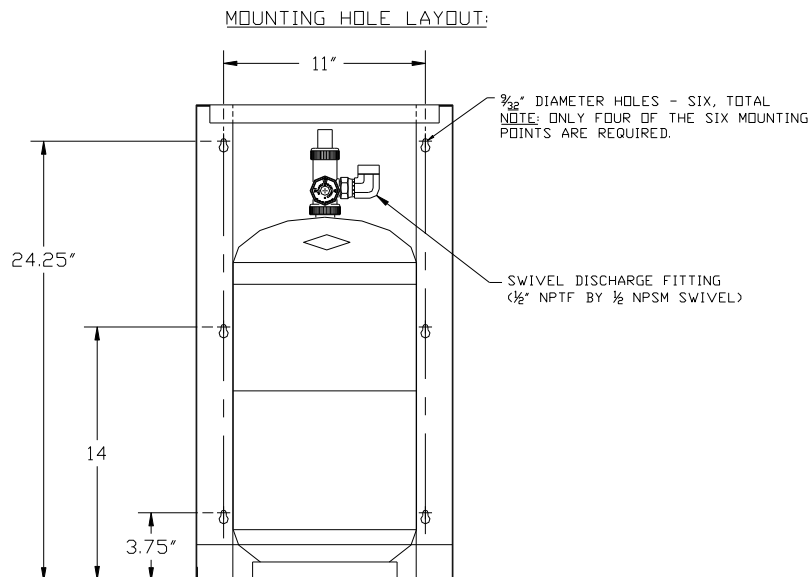

- 2) Place the cylinder inside the enclosure; attach the swivel discharge fitting to the discharge piping network and attach to the valve outlet last. **CAUTION:** Keep the anti-recoil cap (P/N 13219) on the cylinder discharge port at all times except when attached to the discharge piping.
- 3) Push the four black "U-nuts" onto the enclosure flange and align them over the cover mounting holes. The cover is oriented properly when the pressure gauge view port is "up".
- 4) Install the two tamper seals through the cover and enclosure holes (upper left / lower right corner).

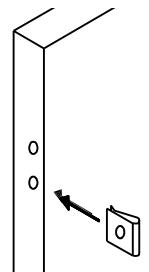

INSTALLING THE PNEUMATIC RELEASE MODULE (PRM):

Select a suitable location for the pneumatic release module (PRM) that has access for installation, service, recharge and where both the nitrogen actuation cylinder pressure gauge and the system status indicator can be viewed. The PRM must be fastened to a surface that has sufficient structure to support the loads anticipated. Knockouts are provided on three sides of the enclosure and each cable run may enter the enclosure from any of the three sides (top, bottom or right).

Using the enclosure as a template, mark the top two holes for mounting and anchor the enclosure loosely, adjust to level and mark bottom holes, anchor loosely using appropriate fasteners.

All installation wiring shall adhere to NFPA 70 (NEC) and all State and Local codes. Terminations of the snap action switch are to be made outside the PRM Enclosure in an appropriate electrical junction box. Do not install nitrogen actuation cylinder at this time or system may accidentally actuate.

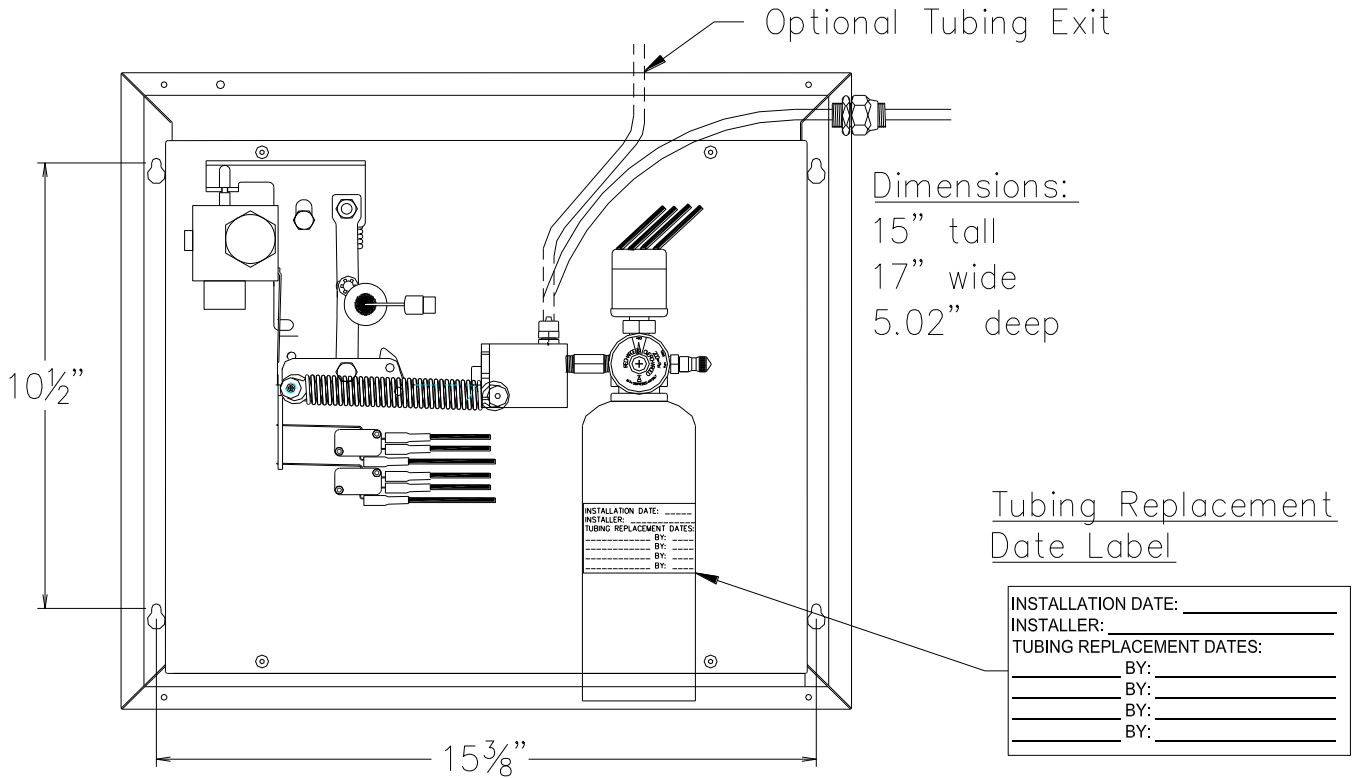

INSTALLATION OF DETECTION NETWORK - PRM

The PRM has provisions for a single, continuous section of detection tubing. No splicing or “tee’s” allowed. There shall be only two tubing terminations: one at the accumulator cylinder inside the PRM, and the other at the opposite end of the tubing, with the use of an End of Line Fitting (p/n 16506).

The Amerex part numbers for tubing lengths are:

P/N	Length	P/N	Length
16557	25'	16579	100'
16551	50'	16552	150'
16556	75'	16554	300'

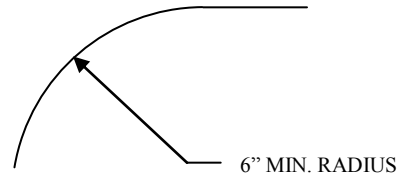

Tubing may be cut down to the required length with the use of Cutting Tool P/N 16860, or be coiled up and secured with wire ties outside the hazard area. Cuts must be square and clean. The minimum bend radius is 6 inches (15.2cm). Do not crimp or crush the tubing in the course of handling or installation. A Tubing Clip (PN 16501) is to be use to secure the tubing every 18" (45.7cm). A Tubing Clip is also required within one inch of the End of Line Fitting. The tubing can exit the enclosure either through the 5/8" hole at the upper right hand corner of the enclosure (where a strain relief fitting is installed at factory), or it can exit through the 5/8" hole at the top right of the enclosure. If it is desired to route it through the top, switch the strain relief fitting with the snap-in plug.

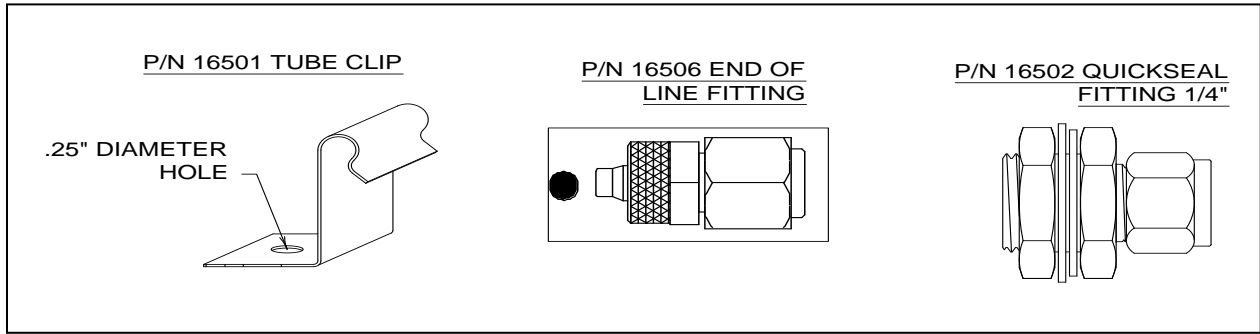

The PN16502 Quick-seal Compression Fitting is required for kitchen hood and other penetrations requiring a UL-listed sealing device.

Warning: When tightening the nut on the PN 16502 Compression Fitting, use a **MAXIMUM** of ½ turn past hand tight. Wrenching the nut past ½ turn can begin to collapse the detection tubing.

TUBING SPACING & ROUTING - PRM

The detection tubing is to be run at the top of the plenum, behind the filters from one end of the plenum to the opposite end to ensure total detection coverage. Ensure that the tubing is routed in such a way as not to interfere with any moving parts or access openings. Tubing must not be obscured by structural or support structures, and should be fully exposed to any rising hot gasses from the cooking media, to ensure rapid detection response. Terminate the tubing within 6” (15.2cm) of the end of the plenum. Refer to page 4-7 for proper end of line installation. The tubing is never to be routed in the path of hot flue gases from a gas fired appliance for this can result in a unwanted discharge. Never locate the tubing where the daily removal of the filters will result in scraping or damaging the tubing surface for this too will result in an unwanted discharge.

Additionally, the detection tubing is to cross over the hood / duct opening in compliance with NFPA – 17A. When the opening width exceeds the 18” (45.7cm) maximum mounting clip spacing, the tubing is to be installed along at least three of the four sides of the hood / duct opening. See figure below:

Top View

Top View

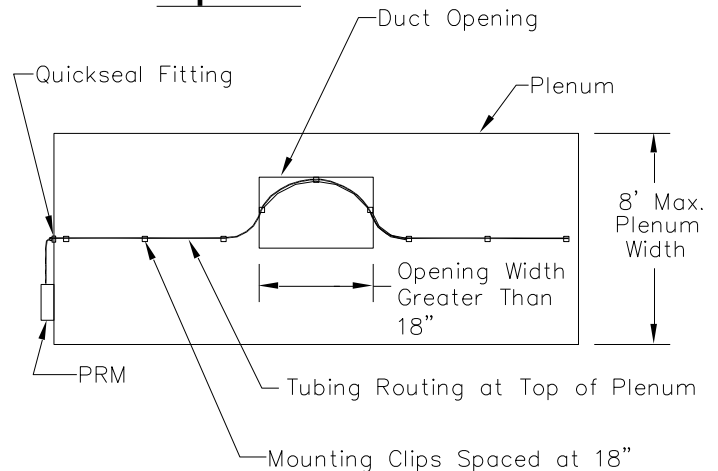
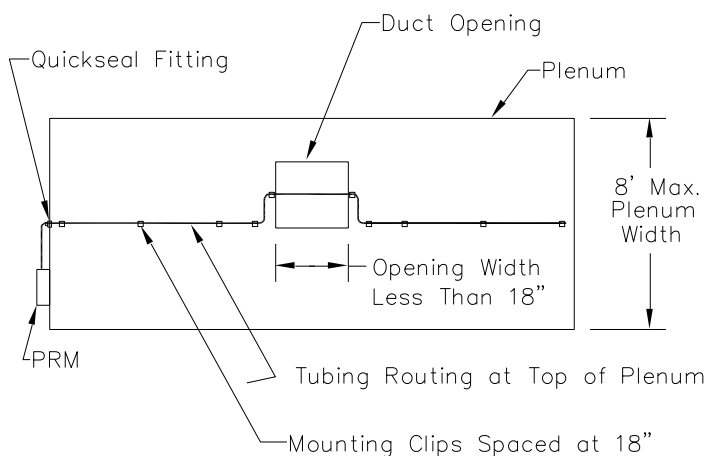

SECURING THE TUBING - PRM

The tubing must be secured at a distance not to exceed 18” with PN16501 Tubing Clip. A Tubing Clip is also required within one inch of the End of Line Fitting. Since the tubing snaps into the clip, it is recommended that the clips be installed first, then the tubing. Ensure that the tubing is routed in such a way as not to interfere with any moving parts or access openings. Tubing must not be obscured by structural or support structures, and should be fully exposed to any rising hot gasses, to ensure rapid detection response. Never take up slack by pulling the tubing through a series of clips, this action could damage the tubing and shorten its useful life.

TUBING TERMINATION - PRM

Care must be taken when terminating the start and end of the tubing to ensure leak proof connections. Below are the instructions for termination:

1. Remove knurled nut from plated tube fitting and slide over end of tubing. The end of the tubing must be cut square and clean. **DO NOT** use pliers or wire cutters for cutting the tube. These tools will collapse the end of the tubing and could create a leak point. The use of a sharp utility knife is suggested, while rolling the tubing on a flat surface. Do not use any sealants on the connection.
2. Firmly push the end of the tube down over the end of the fitting. It may require working the tubing around until it goes on (see following figure). It is important that the end of the tubing be inserted **ALL** the way over the tip of the fitting. Hold the tubing in place **firmly** in one hand while tightening the nut with the other. Use a 12mm wrench (or adjustable) to tighten the nut. Resistance will be felt when the nut bottoms out. Do not over tighten. The procedure is the same for both the accumulator cylinder fitting and the End of Line Fitting. It may be helpful to place the End of Line Fitting in a small vise while terminating the tubing to it.

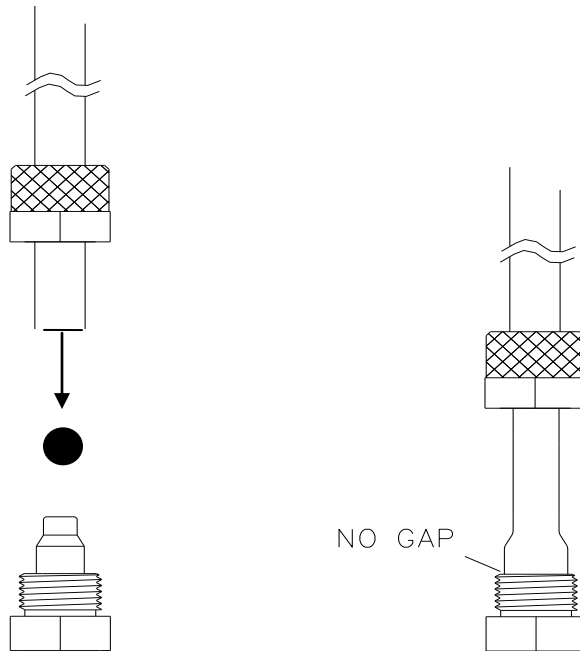

3. Once the system is pressurized and put into service (see below), both connections should be thoroughly leak checked with leak check fluid or soapy water.
4. Record the date of tubing installation on the tubing replacement label and affix the label to the detection accumulator cylinder.

INSTALLING THE MECHANICAL RELEASE MODULE (MRM):

Select a suitable location for the mechanical release module that has access for installation, service, recharge and where both the nitrogen actuation cylinder pressure gauge and the system status indicator can be viewed. The MRM must be fastened to a surface that has sufficient structure to support the loads anticipated. Knockouts are provided on three sides of the two available enclosures (painted or stainless steel) and each cable run may enter the enclosure from any of the three sides (top, bottom or right).

Using the enclosure as a template, mark the top two holes for mounting and anchor the enclosure loosely, adjust to level and mark bottom holes, anchor loosely using appropriate fasteners.

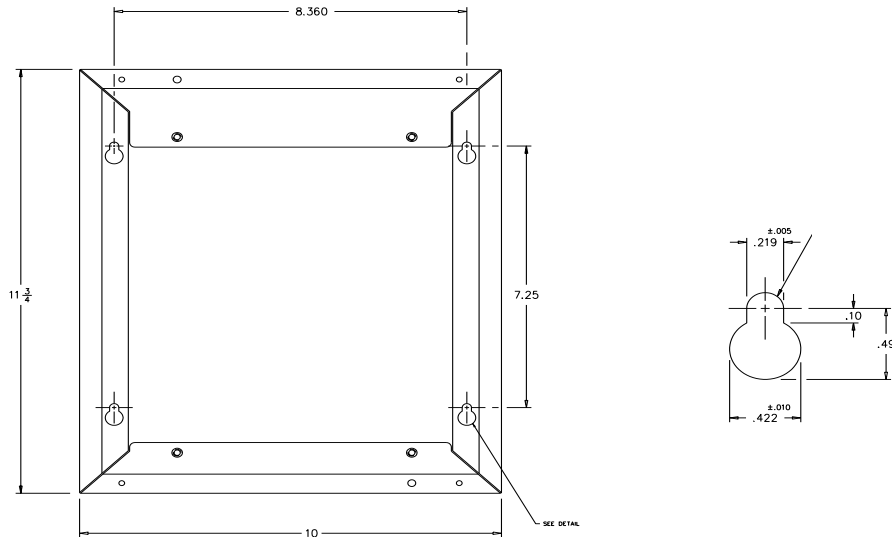

Once the enclosure is loosely attached to the mounting surface the MRM plate can be installed into the enclosure stand offs using the four machine screws provided with the MRM. **Do not install nitrogen actuation cylinder at this time or system may accidentally actuate.** After the MRM plate is installed tighten fasteners anchoring the MRM enclosure to the wall.

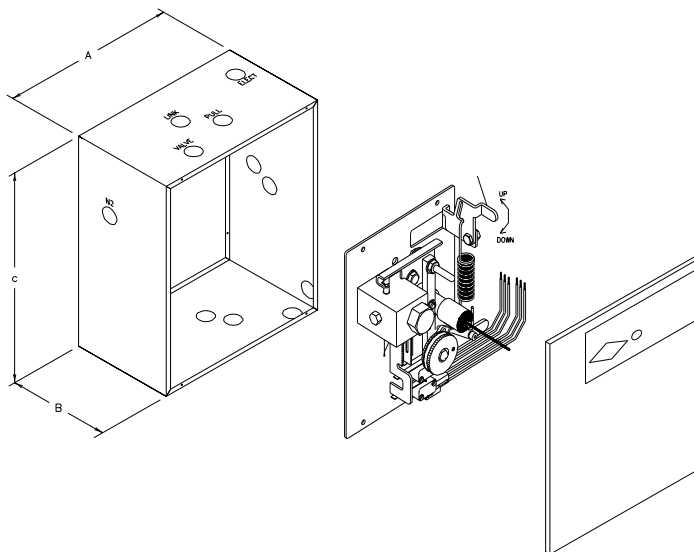

P/N 12853 P/N 13393	U.S.	Metric
(A) Width	10 in.	25.4 cm
(B) Depth	5 in.	12.7 cm
(C) Height	11 3/4 in.	51.5 cm

Special Note:

When the MRM plate is installed in the "optional" P/N 11978 S/S Cabinet remove (unscrew) the factory installed "Status Indicator" from the MRM and install the extended (longer) "Status Indicator" packaged with the Stainless Steel Cabinet

INSTALLING THE DETECTION NETWORK – MRM or MRM II

Refer to the system design section for Detector Network limitations. There is only one type of detector bracket and linkage used with this system. There are, however, two names for detectors in the network – series and terminal. The terminal detector is the detector located at the end of the cable run, furthest away from the MRM or MRM II. A series detector is any detector located in between the MRM or MRM II and the terminal detector in the network.

Starting at one of the corresponding knock-out found on one of the two available sides (top or bottom) of the MRM or MRM II. Install ½” EMT conduit running from the MRM or MRM II to each detector location, using a corner pulley at every change in direction. Each detector must be securely fastened to a rigid surface, located over each protected appliance and in the hood / duct opening. Refer to the Design section for limitations and cautions regarding detector placement.

To install the cable, start at the terminal detector, affix the Cable with a terminal clamp (P/N 12859 provided with the MRM & MRM II) leaving a minimum of 6 inches between the end of the cable and the terminal clamp. From the terminal detector, continue to feed the cable through each corner pulley, detector and length of EMT conduit back to the MRM.

**Position link holder and link
in center (or slightly off center
away from MRM) in bracket**

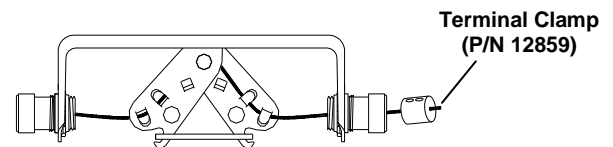

INSTALLING THE DETECTION NETWORK – MRM II

Setting Detection Cable Tension, New MRM II (P/N 18000 and 18001):

Refer to the following images in this section for properly setting the detection cable tension:

1) To set the tension on the cable, first make sure that the tension bar in the MRM II is in the “down” position and that the spring is relaxed. Lower the top hook of the blue spring into the bottom of the tension bar slot.

Warning: Do NOT attempt to set the tension bar in the “up” position (spring stretched) without having a fusible link line installed and secured or the MRM will fire. Take additional caution; DO NOT install the Nitrogen Actuation Cylinder at this time.

2) Feed the cable end into the small hole in the side of the ratchet pulley. The end of the cable must be cleanly cut. Push the cable into the hole until the end is visible at the head of the central hex-bolt. Securely tighten the Allen-head set screw onto the cable. Aside from the use of the cocking tool, no further tools should be used to set the mechanism. (The cable may be routed from either the bottom or the top of the MRM II; the ratchet pulley will always turn counter-clockwise to remove cable slack. – See illustration on Page 4-9A)

3) Spool up the excess cable slack by turning the ratchet pulley counter-clockwise by hand. Continue to hold the ratchet pulley while proceeding to the next step.

4) While maintaining the position of the ratchet pulley with your left hand, press down on the engagement pawl and the linkage bar with your index and middle fingers of your right hand in order to begin the final tensioning process. You will feel and hear the pawl click several times as tension is taken up.

5) Inspect your progress by pulling the upper hook of the blue spring into the top notch of the tension bar; then raise the tension bar. Refer to the illustrations on the following page for proper setting. Repeat steps 1-5 until the bottom of the linkage bar is essentially horizontal, and is aligned within the gray “pie” zone of the indicator label (see Figure B). Lower tension bar until system is ready to test.

To test the Detection Network, refer to Chapter 5, “Testing and Commissioning”.

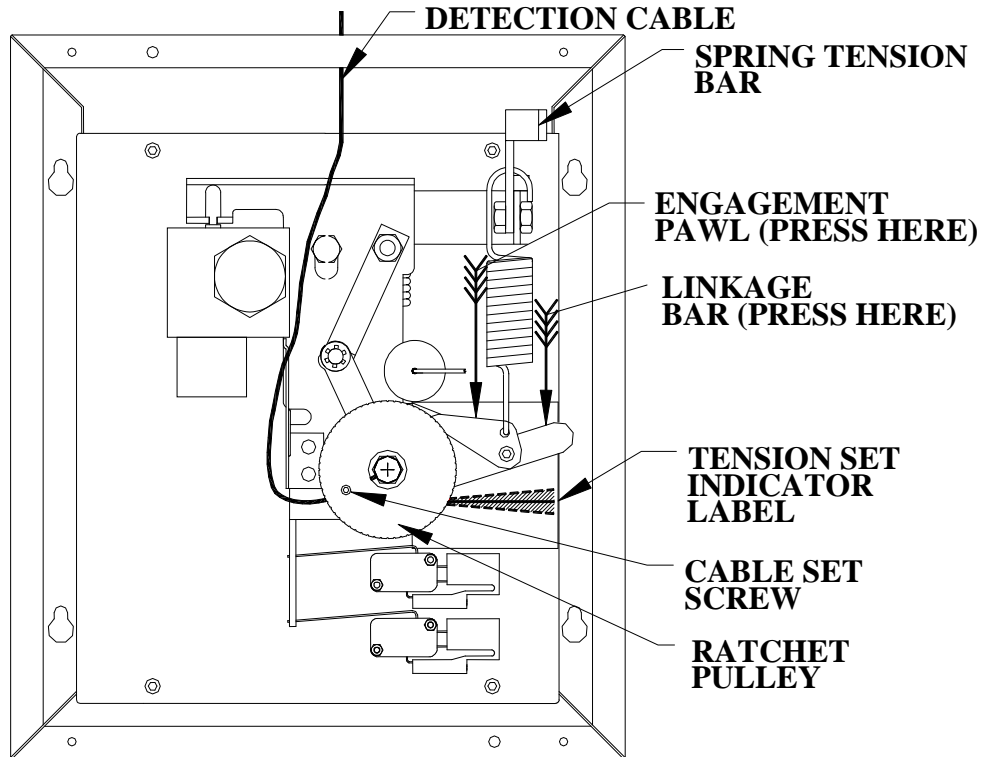
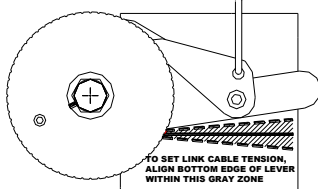

FIGURE A)



Not enough cable tension.

Lower spring tension bar. The lever and pawl must be pulled downward while the ratchet pulley is prevented from rotating. Approximately 2-4 more clicks are required from this position; then raise spring tension bar and re-examine results.

Caution: The MRM may inadvertently cause system discharge if left in this position.

FIGURE B)

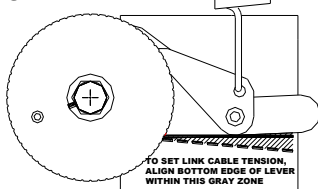

Proper Cable Tension.

Correct Detection Cable tension is obtained when the bottom edge of the linkage bar is aligned within the gray "pie" region of the indicator label, with the spring tension bar in the "up" position. Stand directly in front of the MRM while viewing. The lower edge of the linkage bar will essentially be horizontal.

FIGURE C)

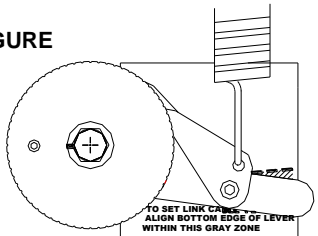

Too Much Cable Tension.

Lower spring tension bar and unhook the blue spring from the tension bar, releasing all tension. Repeat the process until Figure B is achieved. **Caution:** damage to the MRM can result from careless over-tensioning of the assembly.

INSTALLING THE DETECTION NETWORK – MRM

To install the detector linkage, place a weighted object on the cable at the MRM, allowing a minimum of 3 inches of extra cable length for every detector in the network. Starting at the terminal detector, place the linkage upside-down on the cable, run the cable over the rivet and through each of the four tabs as shown above, insert the appropriate fusible link (see the design section for proper selection of fusible links) and turn upright. Repeat these steps for each detector.

Each link and link holder, once assembled and placed on the cable, should be positioned in the bracket on center or slightly off center away from the MRM.

To set the tension on the cable, first make sure that the tension bar in the MRM is in the “down” position and that the spring is relaxed.

WARNING: DO NOT ATTEMPT TO SET THE TENSION BAR IN THE UP POSITION (SPRING STRETCHED) WITHOUT HAVING A FUSIBLE LINK LINE INSTALLED AND SECURED OR THE MRM WILL FIRE.

WARNING: CONDUIT MUST BE SECURED WITH APPROPRIATE ANCHORS AT DISTANCES NOT TO EXCEED 3 FEET. FAILURE TO SECURE CONDUIT PROPERLY MAY CAUSE SYSTEM FAILURE.

Attach the cable to the link plate connector, do **not** clamp tightly (slack must be taken up in a later step). Insert the connector into the slot on the link plate that corresponds with the direction of pull on the cable. The link plate is marked with clock positions (6:00 and 12:00).

Note: Early models also had a 3:00 and 9:00 position which **CANNOT** be used.

Insert the connector at 12:00 if the cable enters the MRM at the TOP or 6:00 if it enters at the BOTTOM.

NOTE: Any excess cable must be secured out of the way of any parts in the MRM. We suggest taping it to the link line cable.

Slip the set-up/lock-out tool (P/N 12738) over the manual pull cam housing until it rests against the outside edge of

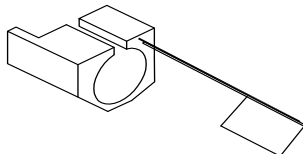

the collapsible linkage. (See adjacent illustration) Draw tension on to the cable through the connector until the link plate is drawn against the set-up tool, then tighten the set screw on the connector.

Remove the set-up tool and raise the tension bar to test cable run. Lower tension bar until system is ready to test. To test the detection network, refer to the testing and commissioning section.

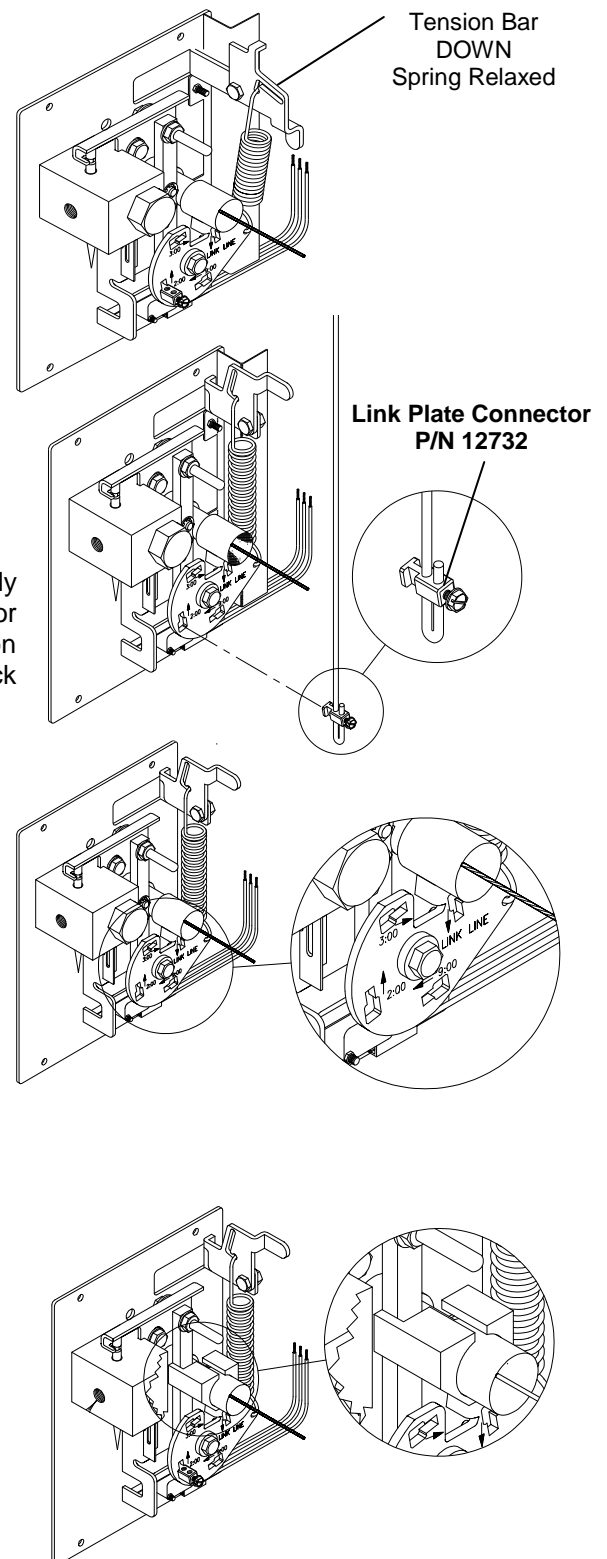

INSTALLING THE LINEAR FUSIBLE LINK DETECTION NETWORK – MRM, MRM II

Refer to the system design section for Linear Fusible Link Detection Network limitations. This network uses no detector brackets and is limited to use in hoods 42' long or less. The terminal connector is located at the end of the cable run. The fusible links and factory fabricated cable segments are supported every eight feet maximum by the use of support eyebolts **PN17520**. Eyebolts must also be located on each side of the hood-duct opening to support the cable crossing the opening.

Starting at any of two sides (top or bottom) of the MRM or MRM II at the corresponding knock-out, install ½" EMT conduit running from the MRM, MRM II to the hood, a maximum distance of thirty feet. This run of conduit may also incorporate the use of a maximum of twenty corner pulleys at every change in direction and conduit must be firmly secured every 36 inches. This portion of the network uses Cable Segment **PN17356 (Part of Purchased Kit 17515)** which consists of one link hook and thirty feet of stainless steel cable. No field fabrication of any Cable Segments is allowed.

The first fusible link must be located within 24 inches of the end of the hood. Each fusible link from this point on must be on maximum 24" centers, which is accomplished by the use of Cable Segment **PN17354** which consist of two link hooks and stainless steel cable the proper length for the maximum 24" spacing. No field fabrication of any Cable Segments is allowed.

The last fusible link in the line must be within 24" of the end of the hood and is terminated by the use of cable segment **PN17355 (Part of Purchased Kit 17515)** which consist of one link hook and 24" of stainless steel cable. No field fabrication of any Cable Segments is allowed. The end of the cable segment is terminated at a conduit handy box by the use of the terminal clamp **PN12859** (provided with the MRM & MRM II). Refer to the Design section for limitations and cautions regarding fusible link placements. The network is to be run in the plenum in a manner that will place a fusible link in the "hood-duct" opening. All cable and links in the plenum are to be in a straight line and supported by eye bolts a maximum of every eight feet. Support eye bolts are to be located in the middle of cable segment runs to allow for the required cable movement.

NOTE: WHEN POSITIONING THE LINKS IN THE PLENUM SO THAT A LINK IS IN THE HOOD-DUCT OPENING IT MAY BE NECESSARY TO LOCATE THE END LINKS AT LESS THAN THE MAXIMUM 24" FROM THE END OF THE HOOD.

To install the linear fusible link network, first measure the distance from the far end of the hood to the middle of the hood/duct opening in inches. Divide this distance by 24 and you will know the number of "Links to Link" Segments (PN17354) required to run from the end of the hood to the middle of the hood/duct opening. You will also require one "Link to Termination" Segment **PN17355 (Part of Purchased Kit 17515)**.

Next measure from the center of the "hood/duct opening to the opposite end of the hood and repeat the process above to determine the balance of "Link to Link" Segments (PN17354) required. You will also require one "MRM to 1st Link" Segment **PN17356 (Part of Purchased Kit 17515)**.

Tension adjustment for the linear fusible link network is to be performed in the same manner described for the standard detection network on page 4-9 and 4-10 of this manual.

INSTALLING THE MANUAL PULL STATION(S) – MRM, MRM II OR PRM

To install the manual pull station(s) first confirm that the set-up/lock-out tool is in place, that the tension bar is down and that an actuation nitrogen cylinder is not installed. **Failure to confirm these conditions could result in the discharge of the system.**

Refer to the design section for manual pull station limitations and suggested locations. The local AHJ should have the final approval for manual pull station location and mounting heights.

The MRM, MRM II or PRM allows the cable for the manual pull station(s) to enter from any of the two sides (TOP or BOTTOM). Once a location for the pull station has been established, ½" EMT conduit is run from the module (using whichever exit side is most convenient) through corner pulleys to the pull station. The manual pull station may be mounted to the wall in any orientation necessary for surface mounting. The conduit and pulley elbows must be mounted and securely anchored and then the cable can be fed from the manual pull station back to the MRM, MRM II or PRM.

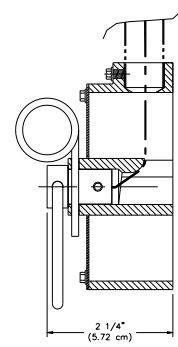
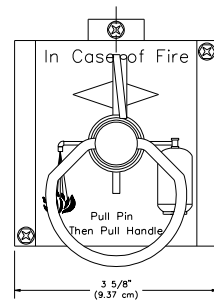

P/N 11993

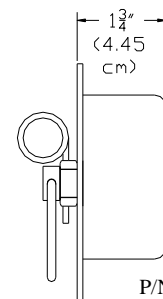
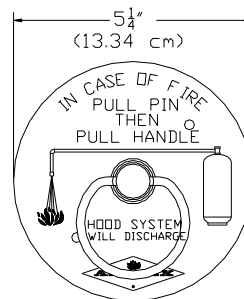

P/N 14320

RECESSED INSTALLATION OF MANUAL REMOTE PULL STATION MRM OR PRM

When installing the Manual Pull Station in a recess configuration, utilize the adapter kit (P/N 14193). The Manual Pull Station Adapter Kit includes an oversized cover plate to cover the hole cut in the sheetrock and/or tile wall. A pull handle extension collar to compensate for the thickness of the wall and two longer attachment screws for the cover plate are also enclosed.

Using the Manual Pull Station Adapter Kit (P/N 14193)

1. Drill 5/32" diameter mounting holes as shown in Figure 1. Holes are located in the side of the box that will be mounted to the stud. Holes may be enlarged to accommodate the mounting screws.
2. Mount box to the wall stud so that the front edge of the box is flush with the front edge of the stud. Attach the box to the stud with two suitable screws.
3. Complete the installation by running ½" conduit with the corner pulleys back to the MRM, MRM II or PRM.
4. Install the "adapter" provided to compensate for the wall thickness. Orient the adapter so that the securing screw falls directly over the pull pin hole of the Manual Pull Station. Tighten the set screw firmly in place.
5. Run the cable from the remote manual pull to the MRM, MRM II or PRM.
6. Install the cover plate on the remote manual pull using the two longer screws provided.
7. Install the pull handle by attaching the cable to the pull handle end – secure cable with the setscrew.
8. Insert the handle and secure with the pull pin.
9. Complete the installation at the MRM, MRM II or PRM as outlined in the preceding pages.

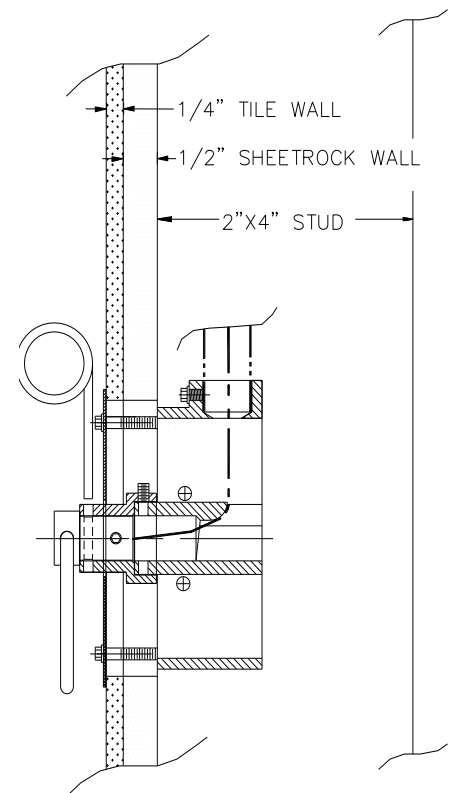

The cable attaches to the manual pull at the handle by using set screws. At the MRM, MRM II or PRM the cable attaches to a cable clamp that is inserted into the fastener on the end of the manual pull cam. Excess cable must be secured out of the way of any parts in the module. We suggest taping it to the manual pull cable.

NOTE: The manual pull cam requires a travel distance of $\frac{3}{4}$ " to actuate the system. It is not necessary to leave excess slack in the cable when installing the manual pull station. Any splices used in the cable must be located at least 12 inches from the pulley tee or any pulley. **The connector in the pulley tee should be located as far toward the MRM, MRM II or PRM as possible.**

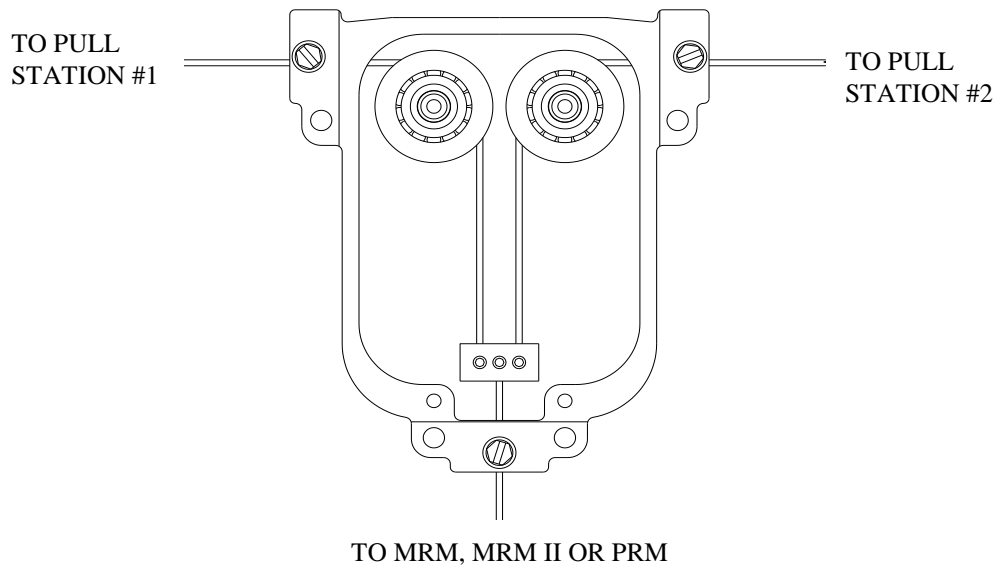
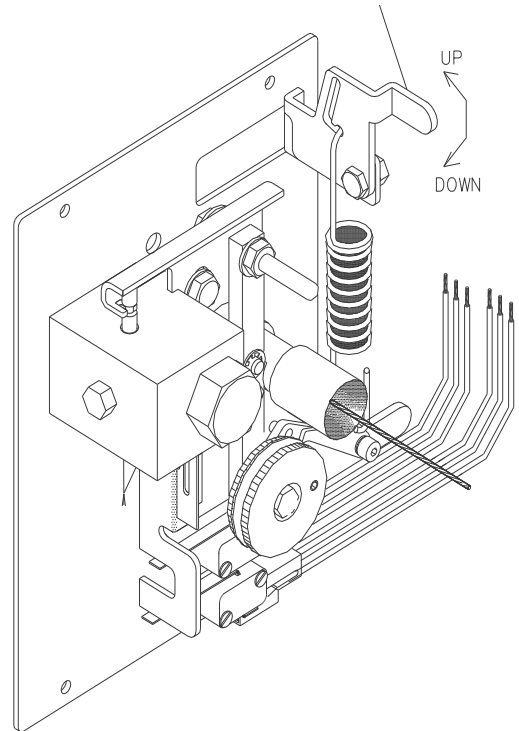

INSTALLING THE ACTUATION NETWORK

Refer to the Design section for limitations of the Actuation Network. Piping for the actuation network can be ¼" black, chrome plated, galvanized schedule 40 pipe, copper tubing or hose. The network originates at the pipe outlet of the MRM, MRM II or PRM and continues to the top of each cylinder and valve assembly. The protective plug on each cylinder valve and the MRM, MRM II or PRM must be removed. All pipe used for the actuation network must be reamed and blown clear, mounted to a sufficient structure, adjusted for level and plumb and fastened in an appropriate manner. Pipe must be fitted **tight (three turns past hand tight recommended)**. **All threaded connections in the actuation network must be sealed with Teflon tape (applied to male threads only)**. Starting with the third thread from the pipe opening, wrap the Teflon tape clockwise around the threads moving away from the pipe opening. Make certain that tape does not extend past the end of the pipe – it could dislodge and possibly block the actuation network.

CAUTION: Do not over tighten the pipe or pipe fittings into the pipe threads on the MRM. Over tightening can cause the MRM to malfunction.

A single MRM, MRM II or PRM will actuate a maximum of ten (10) agent cylinders. The ten cylinder may be any combination of 275, or 375, or 475 Agent Cylinders. When a 600 is included in the mix of agent cylinders the total maximum allowable agent cylinders is lowered to six (6). Outlined below are the maximum amounts of pipe, hose or tubing allowed in the actuation network. When a network consists of more than one of the media listed, the total allowable footage is equal to the smallest of the two media limits.

EXAMPLE: An actuation system made up of black pipe and hose would limit the total footage of pipe plus hose to 22.2 feet.

ACTUATION NETWORK OUTLET

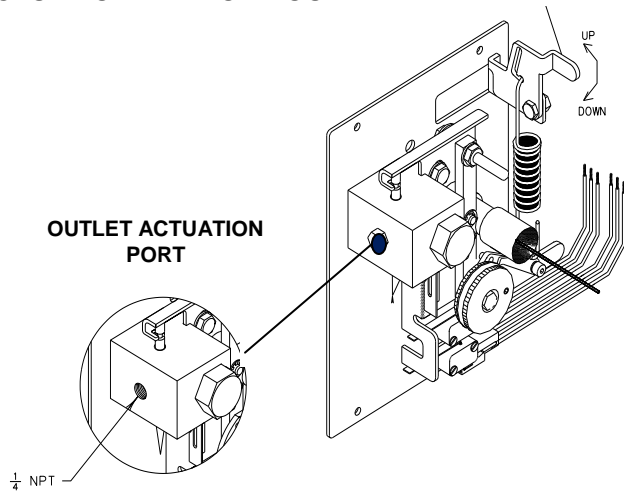

ACTUATION INLET FOR Models 275, 375 & 475 AGENT CYLINDER

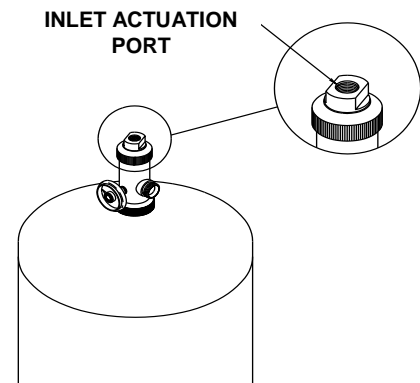

ACTUATION INLET FOR 600 AGENT CYLINDER

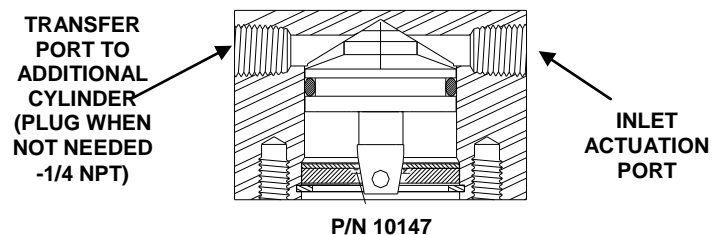

Note: A vent plug (P/N 10173) must be used and placed in an accessible location anywhere in the actuation network to aid in relieving pressure after system discharge, and to keep pressure from building slowly in the network.

See RECHARGE Section 7.

LIMITATIONS (SINGLE OR MULTIPLE AGENT CYLINDER ACTUATION NETWORK)

Copper Tubing – ¼" O.D. Refrigeration Type (minimum wall thickness of .049 inch). Use with brass or steel compression style fittings (with brass or steel sleeves or ferrules) or SAE 45° flared tube fittings. Maximum length (including all fittings) – 100 Feet (30.48 m)

High Pressure Hose – ¼" I.D. wire braid hose that is factory supplied in 16" and 32" lengths. Maximum length (including all fittings) – 54 feet (16.46 m) or a maximum of 40 hose assemblies P/N 12854 or a maximum of 20 hose assemblies P/N 16448.

Pipe – ¼" NPT Schedule 40 made of stainless steel, chrome plated pipe or black iron pipe.
Maximum length – 22.2 feet (6.77 m)
Maximum tees – 9
Maximum elbows – 9

NOTE: 2 – 45° elbows = 1 – 90° elbow

NOTE: Different methods of constructing the actuation network may be mixed provided that the shortest limitations are followed,

Example: A mix of ¼" copper tubing and ¼" high pressure hose requires that the hose limitations be followed (no more than 54 feet [16.46m]) for the complete network. A mix of ¼" high pressure hose and ¼" pipe requires that the pipe limitations be followed (no more than 22.2 feet [6.77m]) for the complete work.

Nitrogen Cylinder	10 cu. in.	
	Feet	Meters
Maximum Total Length for:		
¼" Copper Tubing	100	30.48
¼" ID Hose	54	16.45
¼" Schedule 40 Pipe	22.2	6.77

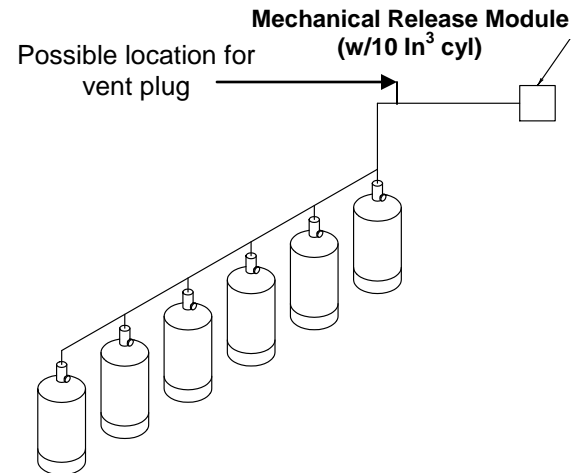

INSTALLING THE DISTRIBUTION PIPING NETWORK:

GENERAL

For distribution piping network limitations please refer to the design section.

ONLY SCHEDULE 40, BLACK, CHROME PLATED OR STAINLESS STEEL PIPE CAN BE USED FOR THE DISTRIBUTION NETWORK. GALVANIZED PIPE IS NOT ALLOWED.

ALL PIPES MUST BE REAMED AND BLOWN CLEAR. DIRT AND/OR CUTTING OIL MUST BE REMOVED FROM THE INSIDE OF ALL PIPE AND FITTINGS BEFORE ASSEMBLY.

All piping must be securely bracketed to a rigid surface using appropriate hangers and/or clamps.

All distribution network pipe and fittings are to be assembled tight (**3 turns past hand tight is recommended**). **THE USE OF TEFLON TAPE IS NOT RECOMMENDED. JOINT SEALANT OR PIPE COMPOUND MAY NOT BE USED UNDER ANY CIRCUMSTANCES. THE USE OF TEFLON TAPE IS TO COMPLY WITH THE MANUFACTURERS RECOMMENDATIONS.**

When using Teflon tape it is to be applied to male threads only. Start installing tape with the third thread from the end of the pipe opening, wrap the Teflon tape clockwise around the threads moving away from the pipe opening. Make certain that tape does not extend past the end of the pipe because it could dislodge and travel to the nozzle filter and block the agent discharge. **NOTE: Blow out distribution piping system several times to insure that no loose pieces of Teflon tape exist inside piping network.**

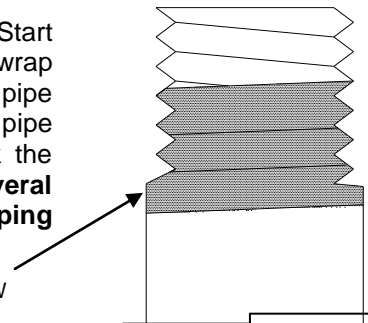

TEFLON TAPE APPLIED BELOW FIRST THREE THREADS

The Amerex Restaurant Fire Suppression System does not require balanced piping. All distribution network piping shall be run in as direct a manner as possible throughout the hazard. The distribution network piping, once installed, shall be compared with the design drawing or sketch, **any changes or deviations shall be noted for use in preparing an “as-built” drawing or sketch for the permanent job file.**

Piping installation shall start at the cylinder bracket and continue through the hazard with tees installed at the beginning of each branch line location. Branch lines shall then be installed taking care to assure that each nozzle is located properly and that no design limitations have been exceeded. **NOZZLE LOCATION AND ORIENTATION ARE CRITICAL TO ACHIEVING PROPER SYSTEM PERFORMANCE.**

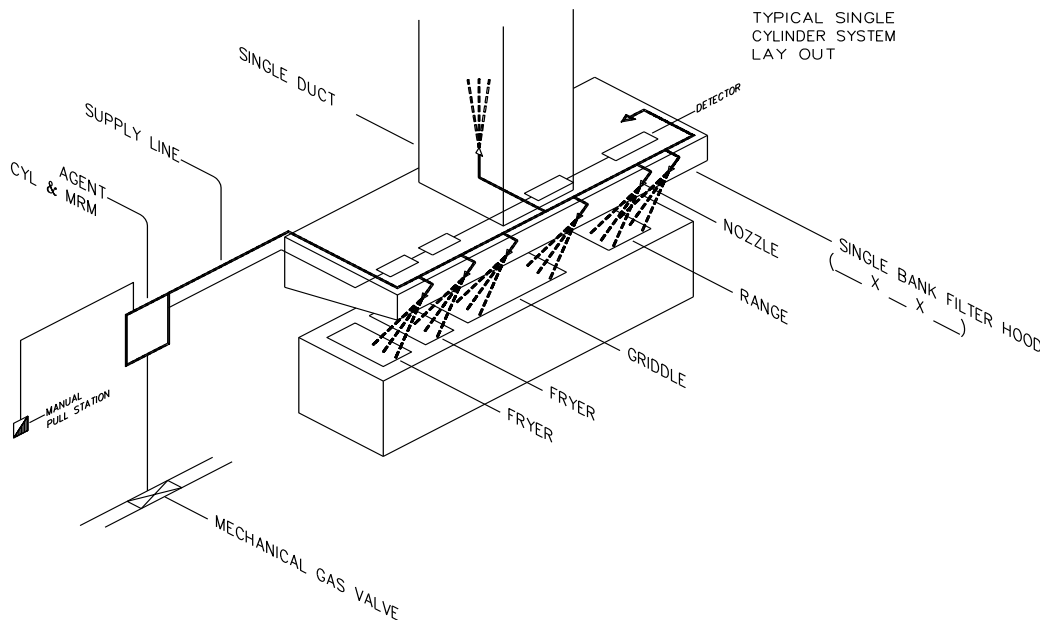

TO INSTALL HIGH TEMPERATURE BLOW OFF CAPS:

- Standard Nozzle:** Remove standard blow off cap – thread the loop of the high temp. cap onto the base of the male threads on the nozzle. Install o-ring on nozzle tip, place cap on nozzle tip.
- Swivel Adapter:** Remove standard blow off cap – thread the loop of the high temp. cap onto the supply pipe before installing the nozzle body. Install o-ring on nozzle tip, place the cap on nozzle tip.

INSTALLING A MECHANICAL GAS VALVE MRM, MRM II OR PRM:

Refer to the design section for limitations regarding mechanical gas valve installations.

WARNING: CONFIRM THAT THE GAS IS SHUT OFF AT THE SOURCE OF SUPPLY BEFORE ATTEMPTING TO INSTALL THE MECHANICAL GAS VALVE. A QUALIFIED, LICENSED CONTRACTOR SHOULD PERFORM INSTALLATION OF THE GAS VALVE INTO THE GAS LINE.

The mechanical gas valve shall be located where it can be accessed for resetting, maintenance, service and where the status indicator may be viewed. The listed temperature range for the mechanical gas valves is 32°F – 120°F (0°C – 49°C).

Before beginning installation of the mechanical gas valve, associated cable, conduit and fittings, confirm that:

1. The MRM/PRM has the set-up/lock-out tool installed.
2. The tension bar is in the “down” (relaxed) position.
3. The nitrogen actuation cylinder has not been installed.

Remove the protective plug from the MRM / MRM II or PRM and install the gas valve trip assembly (P/N 12740). The gas valve trip assembly must be purchased separately for use with ASCO and Ansul gas valves

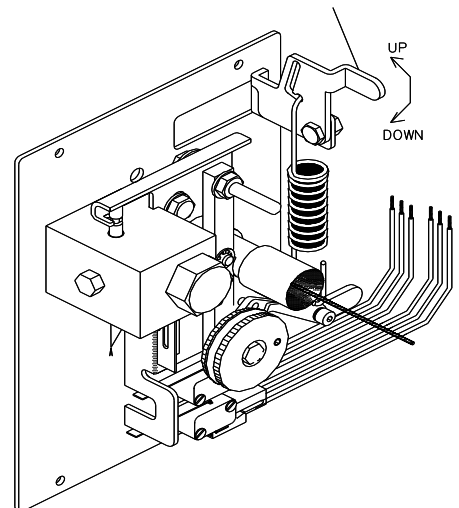

Improper installation of the Red Vinyl Cap may cause failure of the gas valve to close.

AMEREX P/N 12740

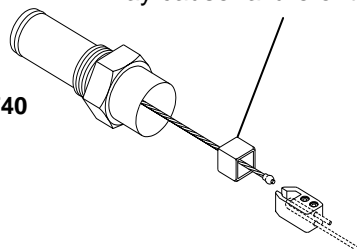

Install the gas valve into the gas line. If any strainers are to be used they shall be placed upstream of the gas valve. Confirm that the valve is installed with the correct gas flow direction as indicated by the arrow on the gas valve body. Wrenches must be placed on the valve at the point closest to the connection being tightened and a “hold” must be placed on the valve when fitting pipe downstream of the valve body.

DO NOT USE THE GAS VALVE AS A LEVER FOR TIGHTENING PIPE.

If pipe joint compound is used, it must be applied sparingly to the back male threads. **Pipe joint compound entering the gas valve and collecting on the valve seat will cause the valve to fail.**

Test the gas valve and connections for leaks using a soapy solution.

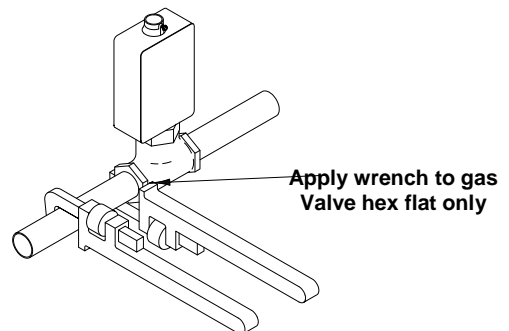

Install necessary 1/2" EMT conduit, cable, tee pulley (if required) and corner pulleys, connecting the MRM, MRM II or PRM to the mechanical gas valve. Confirm that limitations as shown in the design section have not been exceeded.

Note: The cable for the mechanical gas valve may enter the MRM, MRM II or PRM enclosure from two sides (top or bottom).

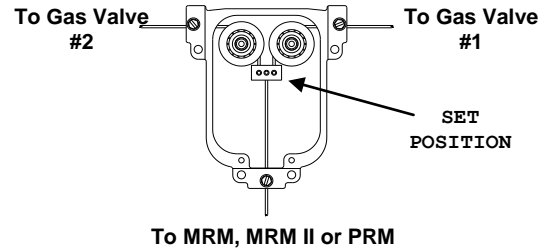

AT THE MECHANICAL GAS VALVE

1. Connect the cable to the latching lever in the gas valve actuator housing by threading it around the pin in the latch (Amerex actuator) or through the hole in the latch (all others). Secure it with a loop and crimp.

NOTE: When using an Ansul Gas Valve make certain that the loop is large enough so that the crimp is inside of the conduit when the valve is cocked.

2. Lift the gas valve stem up and slide the latch into the engaged position.

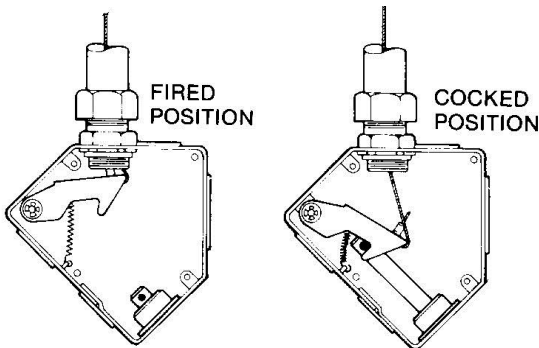
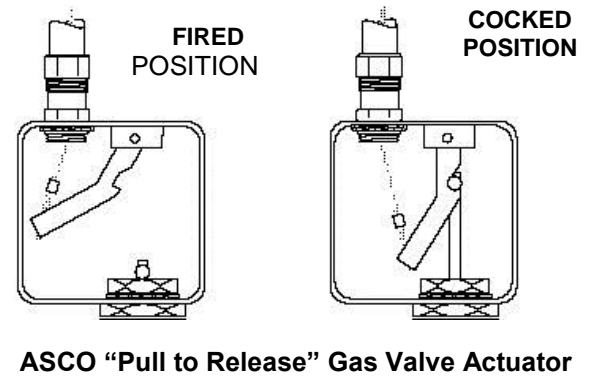
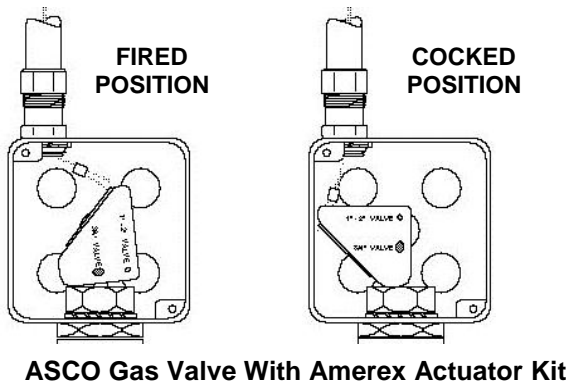
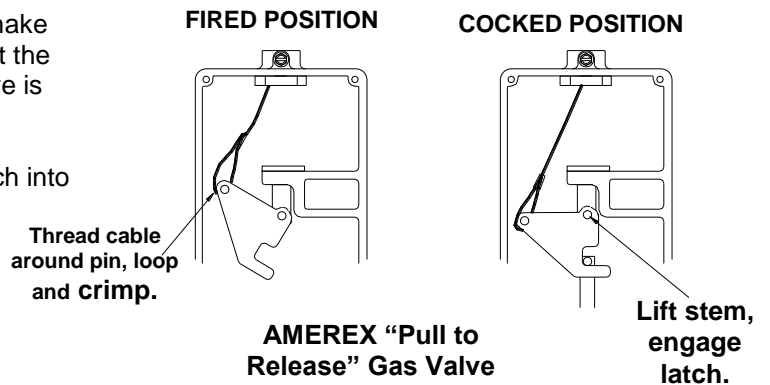

NOTE:
AMEREX MECHANICAL GAS VALVES SIZES 3/4" & 1" MAYBE INSTALLED VERTICALLY OR HORIZONTALLY – ALL OTHER SIZES MUST BE INSTALLED HORIZONTALLY.

FOR ALL OTHER MECHANICAL AND ELECTRICAL GAS VALVES CONTACT THE MANUFACTURER FOR INSTALLATION ORIENTATION.

AT THE MRM / MRM II / PRM

1. Confirm that the cable is moving freely in the corner pulleys and the valve is in the cocked position.
2. Thread the activation cable through the cable connector (provided with the gas valve trip assembly).
3. Install the red vinyl cap above the swaged ball fitting of the gas valve trip assembly by threading the swaged ball fitting through the small ¼" diameter hole in the rear of the vinyl cap.
4. Join the swaged ball fitting of the gas valve trip assembly to the cable connector. Once attached, push the red vinyl cap over the end of the cable connector as illustrated.

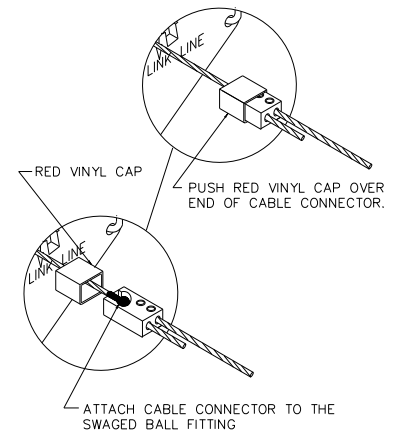

WARNING: IMPROPER INSTALLATION OF THE RED VINYL CAP MAY CAUSE FAILURE OF THE GAS VALVE TO CLOSE.

5. Draw the slack out of the cable. **Make certain that the piston component of the gas valve trip assembly is pulled forward to its fully extended position.**
6. When all of the slack is drawn out of the cable, secure it with the set screws.
7. Test the valve by pulling on the cable inside the MRM / MRM II / PRM until tension is relieved. Confirm that the gas valve has closed.
8. Secure all excess cable so that it is out of the way of any parts in the MRM / MRM II / PRM. We suggest taping it to the gas valve cable.

TO TEST THE OPERATION OF THE GAS VALVE:

1. a. Disconnect and plug the actuation hose or piping
- b. Insert an Amerex P/N 12856 nitrogen cylinder or adapter fitting tool P/N 10895 and outside regulated source of nitrogen into the MRM or PRM
- c. Pull on the manual pull station
- d. Confirm that the gas valve has closed

WARNING: ACTUATION NETWORK IS UNDER PRESSURE – PROCEED WITH CAUTION

2. **Relieve pressure in actuation network by using the vent check.** After all pressure is blown off, slowly remove the nitrogen cylinder or turn off regulated N₂ supply.
3. Reset the MRM or PRM
4. Reset all accessory items.
5. Install a fully charged nitrogen cylinder.
6. Securely connect actuation hose or piping. **Do not over tighten pipe or pipe fittings into the MRM or PRM pipe threads. Over tightening could cause the MRM or PRM to malfunction.**
7. Reset the Mechanical Gas Valve.
8. Remove all set-up tools from the MRM or PRM.
9. Replace and seal the enclosure cover on the MRM or PRM.
10. Replace and seal the cover on the mechanical gas valve.

WARNING: THE MECHANICAL GAS VALVE AND ASSOCIATED COMPONENTS SHOULD BE TESTED AND EXERCISED EVERY TIME THAT SYSTEM MAINTENANCE IS PERFORMED. MAINTENANCE SHOULD BE PERFORMED AT INTERVALS NOT EXCEEDING SIX MONTHS. FAILURE TO TEST THE MECHANICAL GAS VALVE AND RELATED COMPONENTS COULD RESULT IN A TOTAL SYSTEM FAILURE DURING A FIRE INCIDENT.

INSTALLING AN ELECTRICAL GAS VALVE MRM, MRM II OR PRM

WARNING: CONFIRM THAT THE GAS HAS BEEN SHUT OFF AT THE SOURCE OF SUPPLY AND THAT THE ELECTRICAL POWER HAS BEEN TURNED OFF BEFORE ATTEMPTING TO INSTALL THE ELECTRIC GAS VALVE IN THE GAS LINE OR DO ANY WORK ON ELECTRICAL WIRING. A QUALIFIED, LICENSED CONTRACTOR SHOULD PERFORM INSTALLATION OF THE VALVE INTO THE GAS LINE. ALL ELECTRICAL INSTALLATION SHOULD BE PERFORMED BY A QUALIFIED ELECTRICIAN ACCORDING TO THE INSTRUCTIONS PROVIDED BY THE GAS VALVE MANUFACTURER. ALL WIRES SHOULD BE CLEARLY TAGGED, THE SCHEMATIC NOTED FOR FUTURE REFERENCE IN THE PERMANENT JOB FILE AND ALL DISCONNECTED WIRES MUST BE TAPED OR HAVE WIRE NUTS INSTALLED.

Before beginning the installation of an electric gas valve:

1. Confirm that the gas has been shut off at the supply.
2. The tension bar in the MRM, MRM II or PRM is in the “down” (relaxed) position.
3. The set up/lock out tool has been installed and that the nitrogen actuation cylinder is not in place.
4. Install the gas valve into the gas line. If any strainers are to be used, they shall be placed upstream of the gas valve. Confirm that the valve is installed with the correct gas flow direction as indicated by the arrow on the gas valve body. Wrenches must be placed on the valve at the point closest to the connection being tightened and a “hold” must be placed on the valve when fitting pipe downstream of the valve body. **DO NOT USE THE GAS VALVE AS A LEVER FOR TIGHTENING PIPE.** If pipe joint compound is used it must be applied sparingly to the back male threads. Pipe joint compound entering the gas valve could cause the valve to fail.
5. Test the gas valve and connections for leaks using a soapy solution.
6. Install necessary EMT conduit for connecting the MRM / MRM II or PRM to an electrical gas shut-off valve.
7. See Section 3 for wiring schematic.

MOVE THE TENSION BAR TO THE
“DOWN” (RELAXED) POSITION.

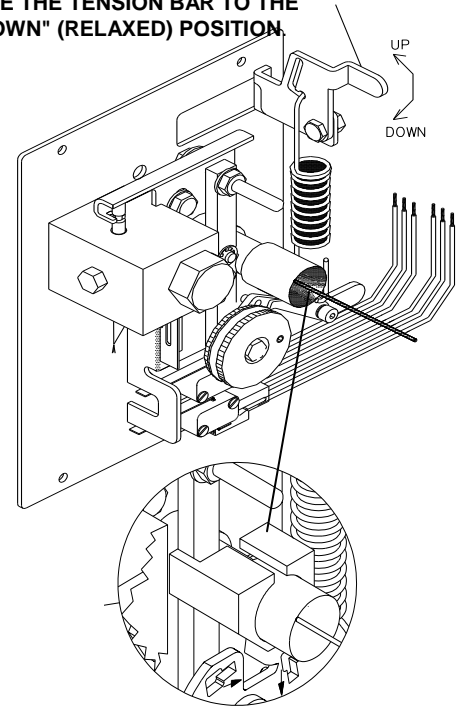

For installation of the snap action switch see section labeled “Snap Action Switch Installation”. The electric gas valve has specific limitations regarding its orientation on the gas line – **please refer to the manufacturer’s instructions.** Confirm that the valve is installed in the proper direction of flow according to the arrow on the valve body and that wrenches are used in the proper manner.

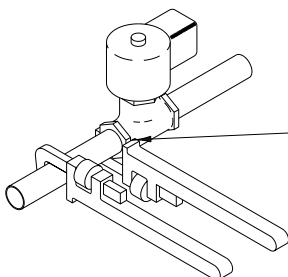

Apply wrench to gas
valve hex flat only

INSTALLING A MECHANICAL GAS VALVE KIT MRM, MRM II OR PRM

The gas shut off valve to be converted to a “pull to close” type should be located where it can be easily accessed for resetting, maintenance and service.

This kit is designed to allow certain specified gas shut-off valves to be interconnected to an Amerex Restaurant System. It is not intended for repair of damage or inoperable gas shut-off valves or to be used with restaurant systems other than an Amerex restaurant system.

1. Insure that the MRM / MRM II / PRM have been locked out properly, refer to the Installation Section.

WARNING: VERIFY THAT THE MAIN GAS SUPPLY HAS BEEN SHUT OFF PRIOR TO INSTALLING THE GAS SHUT OFF VALVE. GAS VALVE INSTALLATION SHOULD BE PERFORMED BY A QUALIFIED, LICENSED CONTRACTOR.

2. Visually inspect the gas shut-off valve stem for cleanliness and damage. Replace the gas shut-off valve if the stem appears damaged or if it will not operate properly.
3. Install the conduit connector as shown in figure 1.
4. Install the outlet box (P/N 13626) using the jam nut (P/N 13625) and the washer (P/N 13624).
5. Install the cotter pin (P/N 08292) through the gas shut-off valve stem and hole that corresponds to the size of the valve (refer to figures 1). Bend the tabs of the cotter pin over to secure it in place. Be sure that the tabs do not interfere with the operation of the holder.
6. Install the necessary ½” EMT conduit, corner pulleys (P/N 12309 or 16444), tee pulleys (P/N 12506) and cable (P/N 12553) to connect the shut off valve to the MRM. For gas shut off valve cable limitations and installation instructions see the Design and Installation sections.
7. Insert one end of the cable through the crimp, through the hole in the rear of the holder then back through the crimp and compress the crimp to secure it in place.
8. To install, set and test the piston assembly at the other end of the cable, refer to the Installation and Testing and Commissioning sections under “Installing a Mechanical Gas Valve”.
9. After testing the actuation of the gas shut off valve, insure that all components of the system are reset. Place the cover on the outlet box and secure it in place.

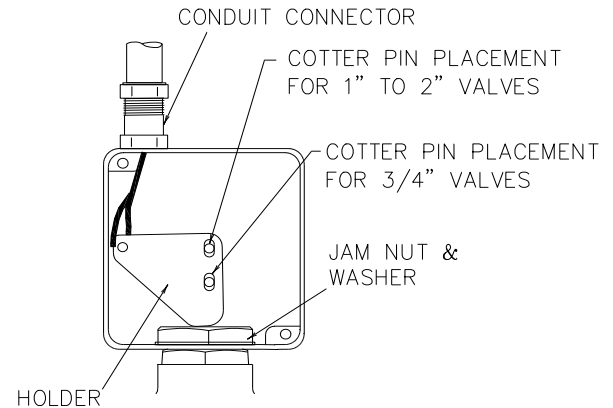
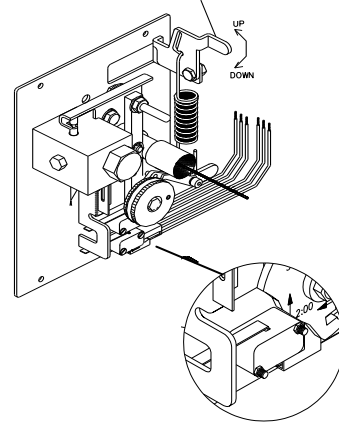

FIGURE 1

SNAP ACTION SWITCH INSTALLATION MRM, MRM II or PRM

Two SPDT switches are pre-installed in the MRM, MRM II or PRM. Before beginning the installation of any additional snap action switch, confirm that the tension bar is in the “down” (relaxed) position, that the set-up/lock-out tool is in place and that the nitrogen actuation cylinder has not been installed. The SPDT switch is mounted with two screws that attach to the plate on the module (screws are provided with the MRM). An additional two SPDT switches may be mounted above and on top of the original set for a total of four switches. A self adhesive wire tie is provided with the module to assure a neat and orderly installation.



Auxiliary connection can now be made to perform required output functions.

Part No.	Contacts	Rating
12524	SPDT	21 Amps 125, 250 or 277 VAC
	Single Pole	1 HP 125, 250 or 277 VAC
	Double-Throw	2 HP 250, 277 VAC

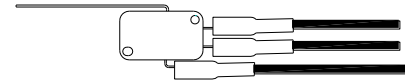

**SNAP ACTION SWITCH
 P/N 12524**

CAUTION: ELECTRICAL CONNECTIONS SHALL NOT BE MADE IN THE MRM, MRM II OR PRM ENCLOSURE. ROUTE THE LEADS FROM THE SNAP ACTION SWITCH THROUGH THE APPROPRIATE KNOCKOUT TO AN ATTACHED, LISTED ELECTRICAL JUNCTION BOX (DISTRIBUTOR SUPPLIED).

CAUTION: POWER TO COOKING APPLIANCES SHOULD NEVER BE RUN THROUGH THE SNAP ACTION SWITCH. THE SWITCH SHOULD BE USED TO OPERATE A SEPARATE, CONTRACTOR SUPPLIED, ELECTRICAL CONTACTOR OR MAGNETIC SWITCH OF SUFFICIENT RATING TO HANDLE THE POWER REQUIREMENTS OF THE ASSOCIATED COOKING APPLIANCES. A LICENSED ELECTRICIAN SHOULD PERFORM ALL ELECTRICAL FIELD WIRING.

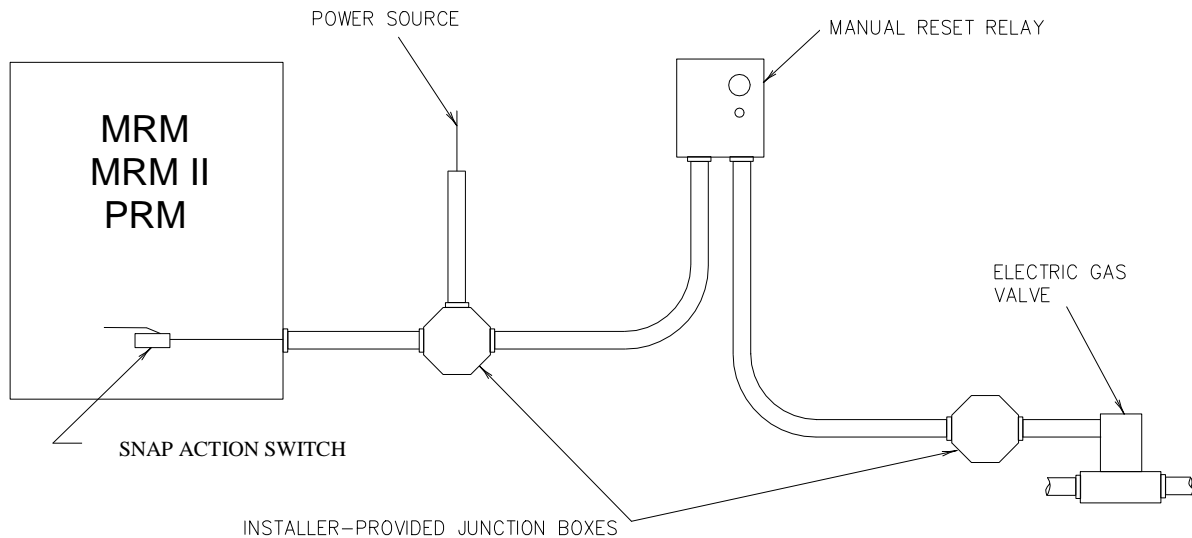

INSTALLING THE ELECTRIC CONTROL HEAD (ECH):

Select a suitable location for the Electric Control Head that allows access for installation, service, recharge and where both pressure gauges of the Nitrogen Actuation Cylinder and the 15 in³ N₂ Actuation Cylinder can be viewed. The ECH must be fastened to a surface which has sufficient structure to support the loads anticipated. Using the backplate as a template, mark the top two holes for mounting and anchor the module loosely, adjust to level and mark bottom holes, anchor securely using appropriate fasteners. **Do not install the Nitrogen Cylinders at this time.** The ECH requires the following components for completion of the control equipment: P/N 19347 Actuation Cylinder, P/N 09956 15 in³ Nitrogen Actuation Cylinder, and the P/N 17014 Electric Actuator. The Electric Actuators of the ECH, and all other electrical components, must be connected to the Amerex-supplied Releasing Control Panel, P/N 19340, Model designation: SR-X.

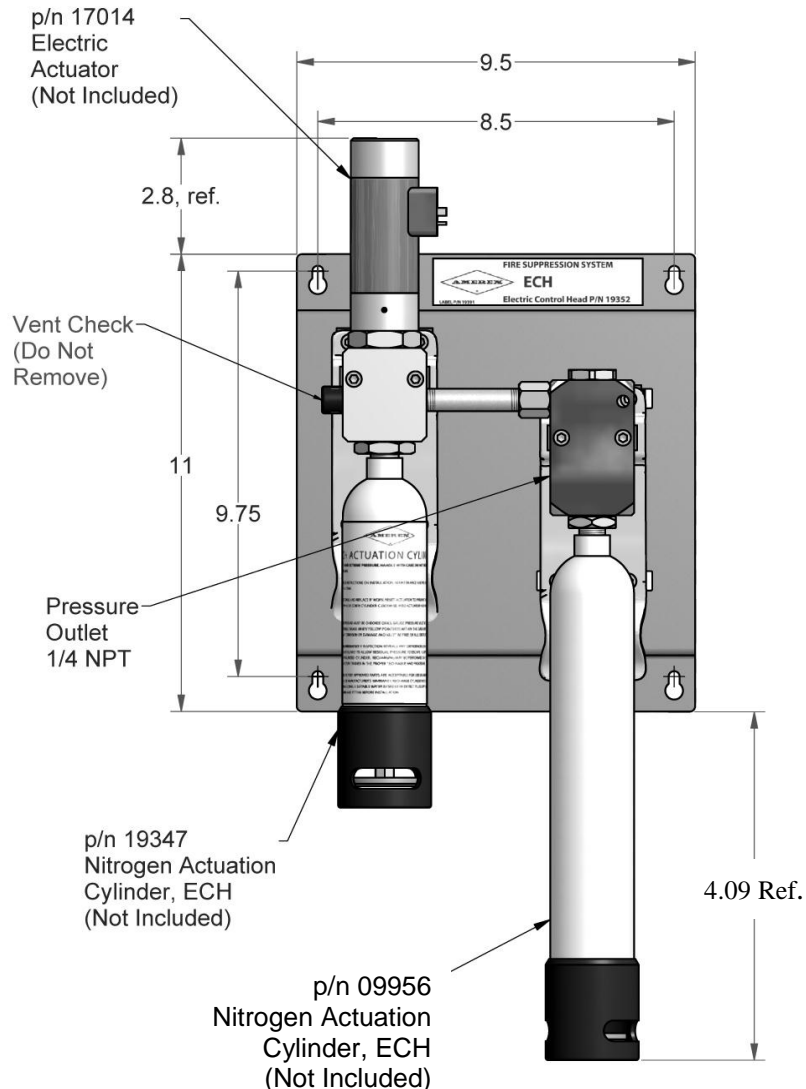
**INSTALLING THE ACTUATION NETWORK**

Refer to the Design Section 3, Page 3-29 for limitations of the Actuation Network. The network originates at the pipe outlet of the MRM / PRM / ECH and continues to each Agent Cylinder Valve assembly. The protective plug at the port on the MRM / ERM / ECH must be removed. All threaded connections in the Actuation Network must be sealed with Teflon tape per page 4-16.

Installation of Nut Style Rivet

Install using AA480 DOUBLE ACTION LEVER TOOL

Instruction Sheet for AK, AL, AH, AO, Series™ and RN Series® Product supplied with each tool.

Please refer to Amerex Restaurant Fire Suppression Manual to obtain proper thread adaptation kit part numbers and size/tool capabilities.

Tool Set-Up Instructions

Installing thread adaptation kit:

1. Remove tool nose housing (C) from tool. Loosen mandrel lock nut (F) one rotation from tool.
2. Thread mandrel (D) fully onto threaded shaft (E) and tighten mandrel lock nut (F) against mandrel (D) with wrenches included.
3. Replace tool nose housing (C) onto tool and tighten.
4. Turn knurled lockdown ring (B) forward to front of nose piece (A).
5. Thread nose piece (A) into tool nose housing (C) approximately two full rotations.
6. Adjust stroke of tool.

The AA480 Tool will need to be adjusted to provide the proper stroke to install the AL product.

To calculate the stroke requirement use the following formula and chart.

$(MG-MT) + PF = \text{Stroke Setting}$

MG = Max grip of the AVK Product. Refer to AVK Engineering Catalog for the appropriate grip specifications.

MT = The thickness of the material you will install the product into.

PF = The pull-up factor. This is the amount by which the overall length of the AVK product is shortened during installation into a parent material of maximum grip thickness. They are as follows.

Thread: 1/4-20UN

Size Series: 1/4, M6 .065 .090 .080 .095

Note: Each horizontal mark on the Gauge (G) equals one millimeter or .040" of stroke. Each 1/2 turn of the knob (I) equals .8 millimeter or .032" of stroke.

7. Set tool stroke using stroke adjustment knob
 - (1). Confirm stroke setting on stroke indicator gauge (G). Make sure the detent (H) is extended into the lobe on the adjustment knob (1).
8. Open tool handle fully and turn nose piece (A) into tool so that the length of exposed mandrel (D) is equal to the overall length of the product being installed.
9. Tighten the knurled lock down ring (B) against the tool nose housing (C).

Tool Operation:

1. Open tool handles.
2. Thread product fully onto tool mandrel (D).
3. Place exposed product into the hole in your parent material. Drill hole 25/64 Dia.
4. Squeeze tool handles together fully.
5. Spin removal knob (J) counter-clockwise removing mandrel/tool from installed product.
6. Measure the AVK product's installed length dimension. Make minor stroke adjustments if necessary. One full rotation of the stroke adjustment knob (H) equals 1 .6mm or .064". 1/2 rotation equals .8mm or .032". Be sure the detent (H) is extended into the lobe on the adjustment knob (1).
7. Perform steps 8 and 9 of the Tool Set-Up Instructions if necessary.

Installation of Stud Style Rivet

Installation using AA480 DOUBLE ACTION LEVER TOOL

Instruction Sheet for AS Series™ Studs supplied with each tool.

Please refer to Amerex Restaurant Fire Suppression Manual to obtain proper thread adaptation kit part numbers and size/tool capabilities.

Tool Set-Up Instructions

Installing thread adaptation kit:

1. Remove tool nose housing (C) from tool. Loosen mandrel Jock nut (F) one rotation from tool.
2. Thread stud mandrel (D) fully onto threaded shaft (E) and tighten mandrel Jock nut (F) against stud mandrel (D).
3. Replace tool nose housing (C) onto tool and tighten.
4. Turn knurled lockdown ring (B) forward to front of nose piece (A).
5. Thread nose piece (A) into tool nose housing (C) approximately two full rotations.
6. Adjust stroke of tool. The AA480 Tool will need to be adjusted to provide the proper stroke to install the Stud Style Rivet.

To calculate the stroke requirement use the following formula and chart.

$(MG-MT) + PF = \text{Stroke Setting}$

MG ~ Max grip of the AVK Product, refer to AVK Engineering Catalog for the appropriate grip specifications.

MT ~The thickness of the material you will install the product into.

PF ~ The pull-up factor. This is the amount by which the overall length of the product is shortened during

installation into a parent material of maximum grip thickness.

They are as follows.

Thread AS Series

Size Product : 1/4, M6 .065

Note: Each horizontal mark on the Gauge (G) equals one millimeter or .040" of stroke. Each 1/2 turn of the knob (I) equals .B millimeter or .032" of stroke.

7. Open tool handle fully and set stroke of tool using stroke adjustment knob (I). Make sure the detent (H) is extended into the lobe on the adjustment knob

(1). Confirm stroke setting on stroke indicator gauge (G).

8. Turn nose piece (A) into tool nose housing (C) so that the AS Series™ stud can be threaded a minimum of four full rotations into the stud mandrel.
9. Tighten the knurled lockdown ring (B) against the tool nose housing (C).

Tool Operation:

1. Open tool handles.
2. Thread AS Series™ stud fully onto tool nose (A).
3. Place exposed tail of stud into the hole in your parent material. Drill hole 25/64 Dia.
4. Squeeze tool handles together fully.
5. Spin removal knob (J) counter clockwise removing tool from installed stud.
6. Measure the AVK Stud's installed length dimension (IL dimension in catalog) make minor stroke adjustments if necessary. One full rotation of the stroke adjustment knob (H) equals 1.6mm or .064". 1/2 rotation equals .8mm or .032". Be sure that the detent (H) is extended into the lobe on the adjustment knob (1).
7. Perform steps 8 and 9 of the Tool Set-Up Instructions if necessary.

FLEXIBLE NOZZLE BRANCH HOSE (PN20473)

This hose is designed to be used when a flexible movement of the nozzle branch line is desired. Such as when an appliance needs to be moved for cleaning and the nozzle protecting the appliance is fixed to the appliance. Hose length is 48" end to end and is supplied with 1/2" NPT ends. **THE FLEX HOSE IS LIMITED TO USE ON THE NOZZLE BRANCH LINE ONLY AND CANNOT BE USED ON SUPPLY LINE OR SUPPLY BRANCH LINE.**

When installing the flexible hose the use of an elbow on the stationary piping at the appliance is helpful in reducing stress on the hose when the appliance is in its cooking position. The nozzle branch drop should be located in a manner that will provide the maximum movement of the appliance without causing the flexible hose to kink or collapse. In some installation this may be directly over the fixed piping and in other installations it may be out board of the fixed nozzle.

Never locate the flexible hose where it is exposed directly to hot exhaust gases. Example: Over the top of an open top char-broiler. The flex hose is never to be installed behind an obstruction or wall.

Only one flex hose is to be used on an individual nozzle branch line. A maximum of three hoses may be used on an agent cylinder piping network. The minimum bend radius of the flex hose is 7" (17.8 cm).

The castered appliance must be furnished with an appliance locating device. This will assure the appliance is returned to the required position after being moved for cleaning.

When attaching the flexible hose to a 3/8" pipe drop, a 1/2" coupling with a reducing bushing may be used to transition from the pipe to the hose.

When a system discharge occurs the hose is to be cleaned and drained of any agent remaining in loops.

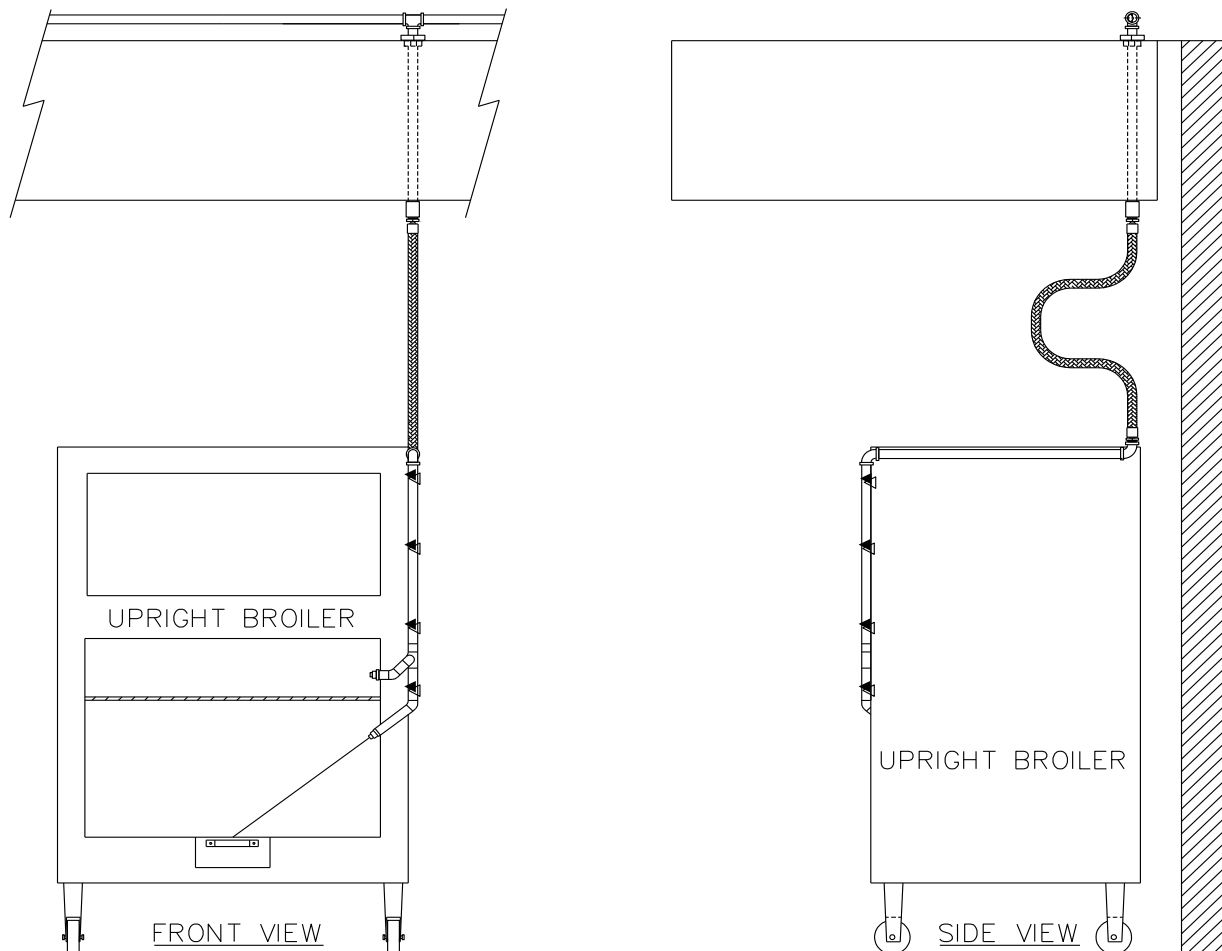

NOTE: The illustration above does not represent the only configuration possible – it is for information only.

SECTION 5

SYSTEM

TESTING & COMMISSIONING

MANUAL P/N 20150

AMEREX

RESTAURANT

FIRE SUPPRESSION SYSTEM

Tested and Listed by
Underwriters Laboratories, Inc.
to UL Standard 300
EX 4658

Tested and Listed by
Underwriters Laboratories of Canada
to UL/ORD 1254.6-1995

December 2008

TESTING & COMMISSIONING

Testing and commissioning shall be performed by a trained and certified Amerex restaurant distributor in accordance with NFPA 96, NFPA 17A and local code requirements.

Once the Amerex Restaurant Fire Suppression System has been completely installed, two sets of tests must be conducted prior to placing the system in service. The detection network, using any fusible link style or the pneumatic tubing, must be tested for functionality along with the manual pull station(s), gas valve(s) and other interlocks. Once this is accomplished and confirmed the action network must be tested using a nitrogen actuation cartridge. Recharging of the nitrogen cartridge can be accomplished by following the instructions on Page 7-6 and 7-7.

TESTING THE DETECTION NETWORK – MRM or MRM II

The **terminal detector** must have a test link (P/N 12891) installed in place of the fusible link. With the nitrogen actuation cartridge removed from the release module; the release mechanism cocked; the tension bar in the “up” (tension) position and the set-up/lock-out tool removed; cut the test link with a pair of dikes or similar device. **The MRM must actuate at this time.**

If the MRM did actuate, follow the reset instructions, place the proper fusible link on the terminal detector and continue with the system test.

If the MRM did not actuate, check to see if:

- the detectors are installed properly,
- that the cable is not binding at any point in the conduit or corner pulley(s),
- that the cable is connected to the link plate properly,
- that the tension bar is in the “up” position and that the set-up/lock-out tool is not in place
- that the conduit is rigidly fastened in place
- that the proper tension exists on the link line

Once these items have been investigated and resolved, **RETEST**.

TESTING THE DETECTION NETWORK - PRM

When first placing the system into service, following system actuation, or at the six month servicing interval, the detection network shall be tested prior to conducting an actuation network test:

1. **Insure removal of the Nitrogen Actuation Cylinder.**
2. Slowly release the detection pressure until the panel actuates by performing either of the following:
 - a Depress the Schrader valve on the detection accumulator cylinder. Replace Schrader cap following actuation and re-pressurization.
 - b Slowly loosen the knurled nut on the end and check for leaks of line fitting. Re-tighten the nut following actuation and thoroughly leak check the entire PRM assembly and tubing following re-pressurization.

If the PRM did actuate, follow reset instructions and continue with the system test.

If the PRM did not actuate, check to see if:

- that the PRM was properly cocked
- that the "End of Line Fitting" did properly vent the pressure from the accumulator
- that the accumulator pressure reading dropped to zero
- that the set-up/lock-out tool is not in place
- that the slide plate and puncture pin are free to function
- that the trip plunger is free to move without resistance

Once these items have been investigated and resolved, **RETEST**.

TESTING THE MANUAL PULL STATION – MRM, MRM II OR PRM

After the detection network has been tested and **before inserting the nitrogen actuation cylinder** the manual pull station(s) must be tested. We recommend having an employee of the restaurant remove the pull pin on each manual pull station, grab the handle and pull away from the mounting surface. Confirm that each manual station did not require a pull force in excess of 40 lbs. and that the handle did not require pulling a distance of more than 14 inches. **The MRM, MRM II or PRM must actuate at this time.**

If the MRM or PRM did actuate, for each station, replace the pull pin, attach a tamper seal and follow the reset instructions.

If the MRM or PRM did not actuate:

- the pull station is installed properly,
- the cable is not binding anywhere in the conduit, corner pulley(s) or pulley tee,
- the cable is connected properly to the manual pull cam in the MRM or PRM,
- the set-up/lock-out tool is not in place.
- The MRM is properly set and cocked.

Once these items have been investigated and resolved, **RETEST**.

TESTING THE MECHANICAL GAS VALVE – MRM, MRM II OR PRM

With the gas on and appliances working, pull on the cable leading to the gas valve where it connects to the piston plug/gas trip assembly in the MRM or PRM. A ½ inch cable movement will be sufficient to close the gas valve. **The gas valve(s) must release at this time.**

If the gas valve(s) do release, follow the reset instructions and continue with the test.

If the gas valve(s) do not release, check to see if:

- it has been installed properly,
- it is fitted tightly into the gas line,
- the cable is not binding in the conduit or in a corner pulley(s),
- it has been connected to the release module properly and that the cable has been secured properly to the gas valve trip mechanism. Insure that the red vinyl cap is properly installed.

Once these items have been investigated and resolved, reset.

TESTING THE ACTUATION NETWORK AND MECHANICAL GAS VALVE WITH A NITROGEN ACTUATION CYLINDER

After performing the mechanical gas valve test above, then you **MUST** test the actuation network and gas valve together using a NITROGEN ACTUATION CYLINDER. Before inserting the NITROGEN ACTUATION CYLINDER insure that all fittings on the actuation line are tight and secure. This test can be done in conjunction with the “puff or air test” or alone.

If testing with a “Puff” test:

Confirm that all components of the system are properly installed and the test cylinders are connected and charged with compressed air or nitrogen – no fire suppression agent. Either the pull station is pulled or a test link is cut to actuate the system. All system functions should occur at this time. Confirm that the gas valve closed, the actuation line was tight and secure, the agent cylinders valves opened and the pipe and nozzles are clear.

If there is no need to perform a “Puff” test:

You can simply connect a valve assembly removed from a cylinder or pneumatic actuator disconnected from the cylinder to the actuation line. Pull the pull station or cut a test link to actuate the system and confirm total system functioning. Insure that the discharge valve is being opened, the actuation line has no leaks, and gas valve(s) closed properly.

TESTING THE DISTRIBUTION PIPING NETWORK

The Amerex Restaurant Fire Suppression System is a wet chemical suppression system using pre-engineered piping limitations that do not require balancing. As long as the design limitations for the distribution piping network as stated in the design section have **NOT** been exceeded, there should be no concern regarding proper distribution of agent at each discharge nozzle. “Bag Tests” or discharge tests are not considered necessary.

“PUFF” TEST

To confirm that the distribution network piping is clear and intact, a “Puff Test” or “Air Test” may be performed. This test may be performed as an individual test or as part of a functional test.

When performing a “Puff Test” as part of a functional test, all other components of the system are installed, including the nitrogen actuation cylinder and an agent cylinder assembly charged with **compressed air or nitrogen only to 100 psi (689.48 kPa) – no fire suppression agent**.

Either a manual pull station is activated or a test link is cut and all system functions, including auxiliary outputs and discharge of air or nitrogen through the distribution piping, should occur at this time. All functions are confirmed and documented and the system is recharged and reset.

To perform the “Puff Test” as an individual test:

- Replace agent cylinder(s) with test cylinder(s) and actuate the system.
- Confirm that each nozzle is clear and continue testing.

TESTING THE ELECTRICAL GAS VALVE – MRM, MRM II or PRM

With the gas valve and the appliances working follow the procedure for testing the manual pull station. When the manual pull station(s) is activated and the MRM/PRM actuates, the snap action switch(es) must transfer contacts cutting off current to the electric gas valve. The Manual Reset Relay shall show an “off” condition. If this does not happen, turn the power to the relay and electric gas valve off and check all electrical connections **RETEST**.

TESTING COMPLETED

After all testing has been completed, follow reset instructions and put the system on line, including the nitrogen actuation cylinder and all tamper seals. The testing procedures and results should be documented in written form with copies left for the owner/manager, Local AHJ (if required) and a copy put into the **permanent** job file. Amerex P/N 13023 “Commissioning Checklist” or similar form shall be used.

A short instruction period on the operation of the system and procedures to use during a fire incident shall be given to the owner or owner’s agent and appropriate employees. A copy of Amerex P/N 12386 “Owner’s Manual” must be given to the owner along with a Material Safety Data Sheet on the Amerex Kitchen Wet Chemical Agent. Review the “Owner’s Manual” with the owner or owners agent.

Any discrepancies found between the finished installation and the design sketches or drawings should be noted and an “as-built” drawing prepared for the permanent job file.

TESTING THE ELECTRICAL GAS VALVE – MRM, MRM II or PRM

With the gas valve and the appliances working follow the procedure for testing the manual pull station. When the manual pull station is activated and the MRM, MRM II or PRM fires, the snap action switch(s) must transfer contacts cutting off current to the electric gas valve. The Manual Reset Relay shall show an “off” condition. If this does not happen, turn the power to the relay and electric gas valve off and check all electrical connections, retest.

TESTING COMPLETED

After all testing has been completed, follow reset instructions and put the system on line, including the nitrogen actuation cylinder and all tamper seals. The testing procedures and results should be documented in written form with copies left for the owner/manager, Local AHJ (if required) and a copy put into the **permanent** job file. Amerex P/N 13023 “Commissioning Checklist” or similar form shall be used.

A short instruction period on the operation of the system and procedures to use during a fire incident shall be given to the owner or owner’s agent and appropriate employees. A copy of Amerex P/N 12386 “Owner’s Manual” must be given to the owner along with a Material Safety Data Sheet on the Amerex Kitchen Wet Chemical Agent. Review the “Owner’s Manual” with the owner or owners agent.

Any discrepancies found between the finished installation and the design sketches or drawings should be noted and an “as-built” drawing prepared for the permanent job file.

ELECTRIC CONTROL HEAD (ECH) SYSTEMS

With the P/N 17014 Electric Actuator removed from the ECH assembly, successively apply heat, from a heat gun, to each thermostat. Each time, the pin at the base of the Electric Actuator should extend with an audible ‘click’. Use the back of a writing pen (or similar) to manually push the pin back up into the Electric Actuator after firing. Reset the Amerex SR-X Releasing Panel upon completion of testing. Inspect the status of the two ECH actuating pins as shown below prior to installing nitrogen cylinders.

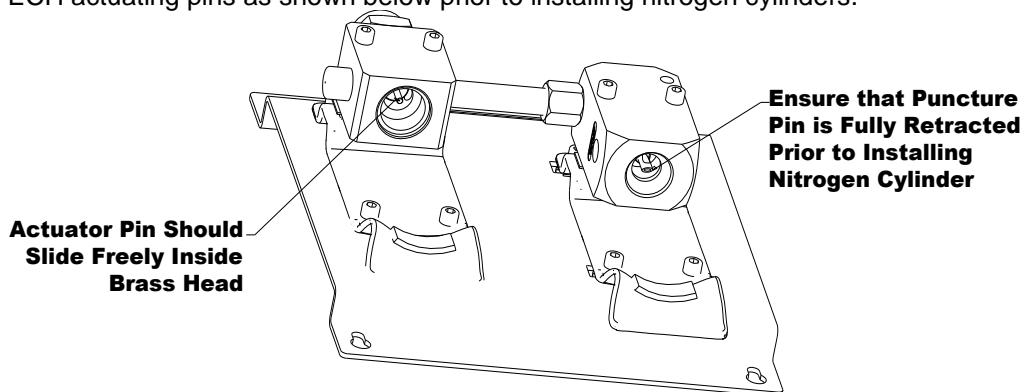

TESTING THE MANUAL PULL STATION OF THE ELECTRIC CONTROL HEAD (ECH) SYSTEM

After the Detection Network has been tested and BEFORE RE-INSTALLING THE ELECTRIC ACTUATOR AND NITROGEN ACTUATION CYLINDERS, the Manual Pull Station must be tested: Pull the FIRE handle on the Manual Electric Pull Station. The pin of the Electric Actuator must extend at this time with an audible ‘click’. Use the back of a writing pen (or similar object) to manually push the pin back up into the Electric Actuator after firing. Reset the Amerex SR-X Releasing Panel upon completion of testing. Re-install the Electric Actuator onto the ECH. **Warning:** Failure to reset the Electric Actuator prior to re-installation will result in system actuation.

SECTION 6

SYSTEM MAINTENANCE

MANUAL P/N 20150

AMEREX

RESTAURANT

FIRE SUPPRESSION SYSTEM

Tested and Listed by
Underwriters Laboratories, Inc.
to UL Standard 300
EX 4658

Tested and Listed by
Underwriters Laboratories of Canada
to UL/ORD 1254.6-1995

December 2008

MAINTENANCE

THE AMEREX RESTAURANT FIRE SUPPRESSION SYSTEM MUST BE PROPERLY MAINTAINED AT INTERVALS NOT EXCEEDING SIX (6) MONTHS IN ORDER TO ASSURE PROPER OPERATION.

MAINTENANCE SHALL BE PERFORMED BY AN AMEREX RESTAURANT FIRE SUPPRESSION SYSTEMS TRAINED AND CERTIFIED DISTRIBUTOR IN ACCORDANCE WITH NFPA 96, NFPA 17A AND LOCAL CODE REQUIREMENTS.

A complete functional test of the system as described in the "Testing and Commissioning" section of this manual shall be performed at every maintenance interval along with the following:

1. Prior to performing any maintenance, remove the cover of the MRM or PRM, install the set-up/lock-out tool and remove the nitrogen actuation cylinder.
2. Compare the number, type and location of each appliance with the "as-built" drawings or the previous system service. Note any changes in writing to the owner or the owner's agent and put a copy of the notification in the permanent job file. **CHANGES IN THE COOKING LINE WILL HAVE A MAJOR EFFECT ON THE SYSTEM DESIGN AND PERFORMANCE.** If appliances have been added or changed the system may have to be redesigned.
3. Note the condition of the hood and duct, including grease build up and code violations (both local codes and NFPA 96 and NFPA 17A). **Notify the owner or owner's agent of any problems or code violations – in writing with a copy to be placed in the permanent job file.**
4. Check the entire distribution network piping, nozzles and caps to verify that they have not been altered or damaged. Perform "puff test" or "air test" in accordance with "Testing and Commissioning" instructions using a **NITROGEN ACTUATION CARTRIDGE.**

CAUTION: SOME HOOD AND DUCT CLEANING PROCEDURES MAY DAMAGE THE DETECTION NETWORK OR LEAVE DETECTORS IN A CONDITION WHERE THEY MAY NOT OPERATE. AMEREX RECOMMENDS THAT THE SYSTEM BE SERVICED AFTER EACH CLEANING BY AN AUTHORIZED AMEREX RESTAURANT SYSTEMS DISTRIBUTOR.

5. **Amerex requires that all fusible links be replaced in intervals not to exceed 6 months.** Links that do not need replacing must be thoroughly cleaned before being put back into service. Any fusible link found to be damaged, painted or having excessive grease must be replaced regardless of age. The links that are removed shall be destroyed. Any link exposed to excessive heat or flame shall be removed from service and destroyed.
6. A system using the PRM requires that the tubing be replaced at intervals not to exceed (3) years. Record the installation date and the date of replacement on the tubing replacement label on the Detection Accumulator Cylinder. The entire length of tubing must be replaced, either at the three year interval or following a fire incident. If grease or coating build-up is excessive, a more frequent replacement interval will be required. At a minimum, excessive build-up is defined as when material completely encircles the tube at **any** point along its length. Cleaning the tube is acceptable, provided that no abrasives are used, and that the text on the outside of the tubing is still legible when completed. **Use only a soft cloth with mild detergents and warm water. If the tubing appears brittle or charred REPLACE it. "When in Doubt, Take it OUT". Corrective action should be taken to re-evaluate the environment where the tubing is installed, or a more frequent tubing inspection and/or replacement interval must be used.** The End of Line Fitting Assembly (P/N 16506) must be replaced when the tubing is replaced. Do not attempt to re-use the Fitting or the Sealing Ball. Thoroughly leak check the tubing terminations following re-installation and re-pressurization.

7. The Pneumatic Release Module (PRM) o-ring (P/N 17692) on the brass actuation piston must be replaced every six months.
 - a. Materials required: 1 1/8" open-end wrench, 5/32" Allen wrench, clean, lint-free shop towels, o-ring (P/N 17692), and Visilox lubricant (available as p/n 06247 in a 5 oz. tube).
 - b. Remove the cover of the PRM and make sure the nitrogen actuation cylinder is removed. Remove the screw anchoring the spring to the brass block with a 5/32" Allen wrench. The silver lever should now swing down away from the brass block.
 - c. Unscrew the cap off of the Schrader valve and bleed the pressure off of the accumulator cylinder. Confirm that the pressure gauge reads zero.
 - d. With the 1 1/8" open-end wrench, loosen and remove the brass hex nut that retains the piston spring and piston inside the brass block. A shop towel may be required to grip the end of the brass piston for extraction from the block. Take care to use only your hands to remove the piston. **VERY IMPORTANT: DO NOT use pliers or tools to remove the piston from the bore or the o-ring from the piston groove. Scratches will cause system leaks and unwanted system discharges.**
 - e. With a clean shop towel, wipe out all the old grease from the inside the cylindrical bore at the deepest point inside the brass block. Using the Visilox V-711 lubricant, **thoroughly and completely** wipe the internal bore in a circular motion with a clean finger. Make sure that you reach all the way to the rear of the bore with the lubricant.
 - f. Clean off the old grease from the piston o-ring. Using a dry shop towel, 'pinch' the o-ring until it can be slipped over the end of the piston by hand. **DO NOT** use a sharp instrument to remove or cut the old o-ring off of the piston – scratches on the brass will create a leak point. Clean the groove of the piston prior to installing the new o-ring. Liberally lubricate the o-ring on the piston with Visilox before inserting into the brass block.
 - g. **VERY IMPORTANT – Lubricate both the o-ring and the internal bore! Use NO TOOLS to remove the old o-ring.**
 - h. After inserting the new piston all the way into the bore, slide the spring over the end and re-tighten the brass hex retaining nut until resistance is felt. Do not over-tighten, as spring tension will present the nut from backing out.
 - i. Temporarily pressurize accumulator through the Schrader valve with approximately 40-50 psi. Re-attach the screw which retains the lever spring to the corner of the brass block. Tighten securely. Latch the tip of the actuation lever under the exposed tip of the piston.
 - j. Apply the lube totally around the perimeter of the exposed brass piston tip of the trip mechanism. Work the piston in and out several times to distribute the lube. Additionally, place some lube on the tip of the spring-loaded lever where it contacts the underside of the piston tip.
 - k. Re-pressurize to 70 psi and leak check all fittings. Perform a full function test of the PRM at this time, as well as the remainder of the six month maintenance.
8. Use the digital thermometer to record the temperatures found at each detector location (with appliances running) and compare with those temperatures found at the same location during the last system maintenance. Insufficient air movement, excessive grease build up and appliance changes can cause temperatures to elevate even to the point of system discharge without a fire occurring. **INCREASING THE TEMPERATURE SETTING OF THE FUSIBLE LINK IS NOT AN ACCEPTABLE SOLUTION TO THIS PROBLEM.**
9. The agent cylinder assembly and nitrogen actuation cylinder must be checked for proper pressure (within the green pie **OPERABLE RANGE** on pressure gauges).
10. The agent cylinder and all hose assemblies must be hydrostatically tested at a minimum of every 12 years.
 - a. Agent Cylinder – test to 480 psi (3309 kPa)
 - b. Actuation Hose (if used) – test to 3500 psi (24131 kPa)
 - c. Distribution Hose – Test to 480 psi (3309 kPa)

If the agent cylinder or hose assemblies have been subjected to physical damage, excessive heat or corrosion they should be hydrostatically tested or replaced regardless of their age.

11. Replace nitrogen actuation cylinder, REMOVE SET UP/LOCK OUT TOOL, replace the MRM cover and install new tamper seals.
12. After performing a complete functional test of the system the owner or owner's agent shall receive some documentation on the maintenance performed (with a copy to be placed in the permanent job file) and instruction on how the system and related hand portable fire extinguishers work, including procedures for incidents.
13. Note date of service on Inspection/Maintenance tag to attach to the system.

SECTION 7

SYSTEM RESET & RECHARGE

MANUAL P/N 20150

AMEREX

RESTAURANT

FIRE SUPPRESSION SYSTEM

Tested and Listed by
Underwriters Laboratories, Inc.
to UL Standard 300
EX 4658

Tested and Listed by
Underwriters Laboratories of Canada
to UL/ORD 1254.6-1995

December 2008

RESET AND RECHARGE

RESET PROCEDURES – MRM & MRM II

Each time the MRM is fired the following procedures must be performed to accomplish reset:

1. Remove cover of the MRM / MRM II and move the tension bar to the “down” (relaxed) position. Move the upper end of the blue spring into the lower end of the spring slot.
2. Cock the MRM by simultaneously pushing in on the lock spring and turning the “Cocking Tool” counterclockwise. The mechanical pull piston must be pushed in all the way.
3. Insert the set-up/lock-out tool after cocking.

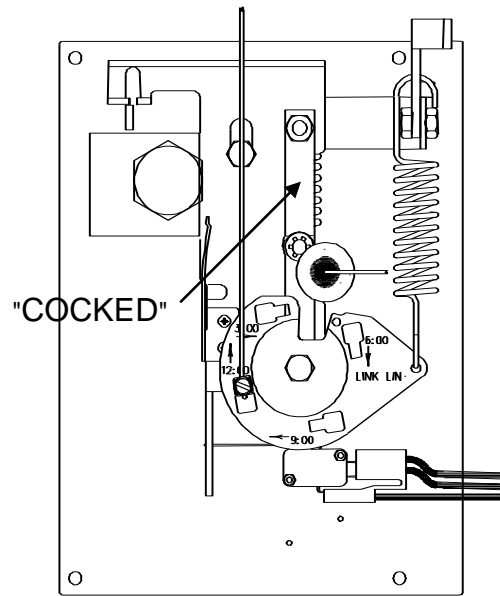
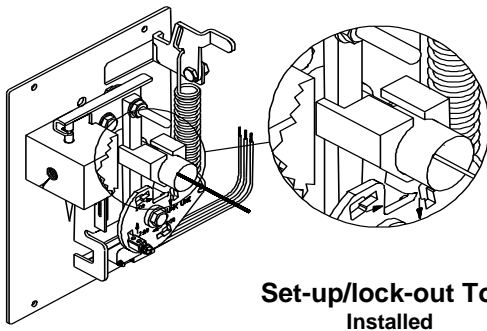
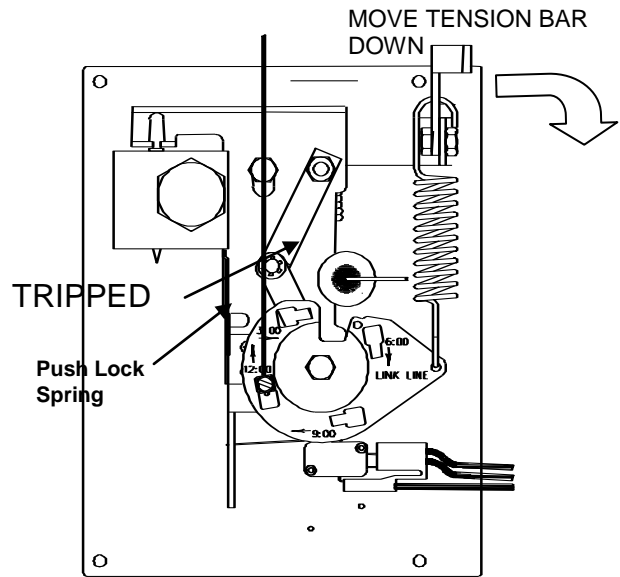

4. If a nitrogen actuation cylinder was expelled, relieve pressure from the actuation network by either loosening a fitting or depressing the ball in the vent check. Remove the nitrogen actuation cylinder.
5. Confirm that all detectors are assembled and fusible links are properly installed.
6. Leave the set-up/lock-out tool in place and verify that the cable for the detection network is properly attached to the link plate.
NOTE: Refer to page 4-8 for MRM II Detection Cable Adjustment.
7. Confirm that the manual stations have pull pins inserted and tamper seals installed.
8. Check to see that the manual pull cam in the MRM is pushed in all the way and the cable to the pull station is properly attached.

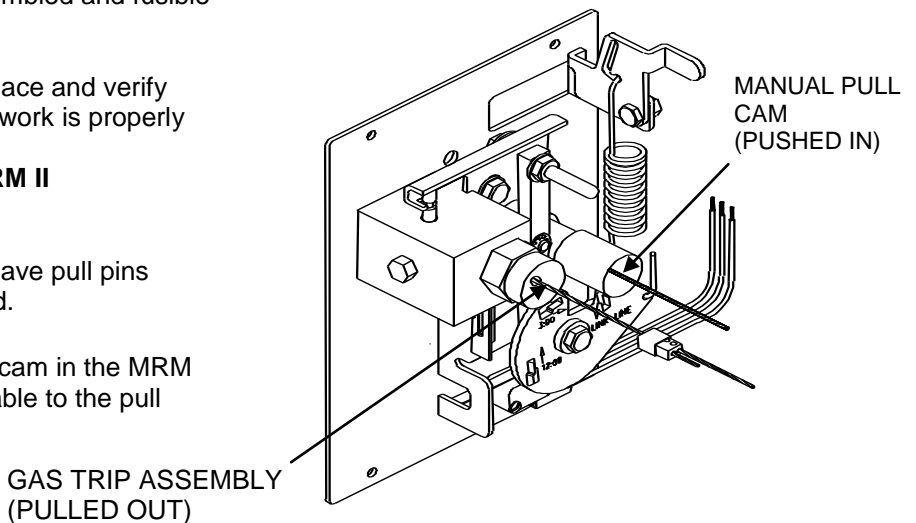

MECHANICAL GAS VALVES – DO ALL EXCEPT STEP 12
ELECTRICAL GAS VALVES – SKIP STEPS 9 THROUGH 11

15. Confirm that the swaged ball fitting of the gas valve trip assembly is pulled all the way out and that the cable connected to the gas valve is properly attached using the cable connector and secured by the red vinyl cap.
9. To reset the mechanical gas valve, disconnect the cable for the mechanical gas valve where it attaches to the connector on the piston plug/gas trip assembly.
10. Go to the mechanical gas valve location, remove the cover, lift the valve stem and latch it open, reattach the cable in the MRM / MRM II to the piston plug/gas trip assembly. Replace the cover.
11. To reset an electrical gas valve, the microswitches will transfer the contacts back to normal position when the MRM / MRM II is cocked. The manual reset relay must be reset in order to open the electrical gas valve.
12. To reset other auxiliary electrical functions, the same procedure as used for the electrical gas valve must be followed.
13. Any alarm signals that are connected to a building fire alarm system can be cleared after cocking the MRM / MRM II and resetting the building fire alarm panel.
14. After all input and output functions have been restored or reset, insert a fully charged nitrogen actuation cylinder, REMOVE THE SET-UP/LOCK-OUT TOOL, replace the MRM / MRM II cover and install two new

**WARNING: IS THE SET-UP/LOCK-OUT TOOL IN YOUR POCKET OR IN YOUR TOOL BOX?
 THE SYSTEM WILL NOT FIRE IF IT IS STILL INSTALLED IN THE MRM!**

RESET PROCEDURES – PRM

Each time the PRM is fired the following procedures must be performed to accomplish reset:

1. Pressurize the Accumulator Cylinder to approximately 35 PSI (241 kPa) with compressed air through the Schrader Valve. The Trip Plunger should extend.
2. Rotate the Spring Loaded Lever clockwise ("1" in Figure A), until its tip is latched under the Trip Plunger. Resume pressurization of the Accumulator Cylinder to 70 PSI at 70°F (483 kPa at 21°C). Leak check the fittings at both ends of the tubing. Re-make tubing terminations, if necessary.
3. Using the Amerex Cocking Tool, p/n 13341 in conjunction with a 3/8" drive socket wrench and extension, re-cock the Collapsible Column ("2" in Figure A). This is accomplished by simultaneously pushing in on the Lock Spring while turning the Cocking Tool counterclockwise. The mechanism should now appear as depicted in Figure B.
4. Replace the Nitrogen Actuation Cylinder (p/n 12856).

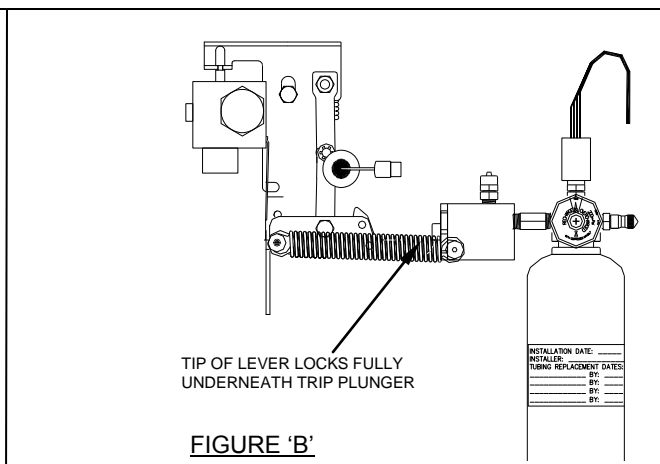
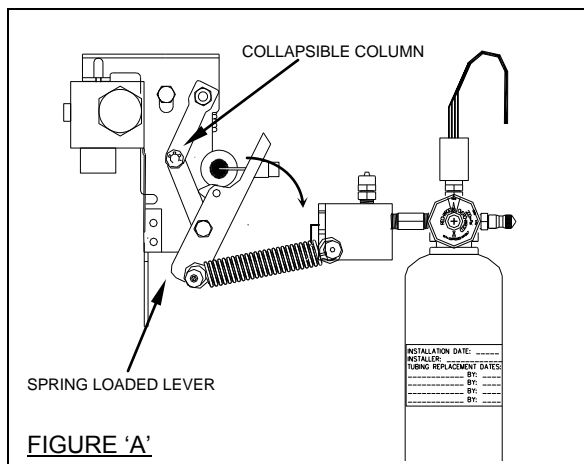

RECHARGE PROCEDURES (275, 375 & 475 CYLINDER)

WARNING:

BEFORE ATTEMPTING ANY RECHARGE PROCEDURES, FIRST CONFIRM THE REASON FOR THE DISCHARGE AND CORRECT ANY CONDITIONS THAT CAUSED THE SYSTEM TO DISCHARGE. THE AMEREX KP RESTAURANT FIRE SUPPRESSION SYSTEM MUST BE RECHARGED IMMEDIATELY AFTER ANY DISCHARGE REGARDLESS OF THE CAUSE FOR DISCHARGE. IF RECHARGE CANNOT BE ACCOMPLISHED IMMEDIATELY – DO NOT LEAVE THE SYSTEM INCAPACITATED FOR ANY REASON WITHOUT GIVING WRITTEN NOTIFICATION TO THE OWNER, OWNER’S AGENT, LOCAL AHJ AND DOCUMENTING THE INCIDENT IN THE PERMANENT JOB FILE. ANY SYSTEM COMPONENTS SUBJECTED TO FIRE OR OVERHEATING CONDITIONS MUST BE REPLACED, INCLUDING BUT NOT LIMITED TO CYLINDERS, BRACKETS, DETECTORS, NOZZLES, PIPING, CONDUIT CABLE.

1. Relieve all pressure in the actuation line by depressing the ball check in the vent check or loosening a fitting.

WARNING: ENSURE THAT ALL PRESSURE HAS BEEN RELIEVED FROM CYLINDER BEFORE PROCEEDING.

2. Vent trapped actuation pressure in discharge valve by depressing the stem of the Schrader valve located in the top of the valve cap of the discharge valve.
3. Slowly remove agent cylinder assembly from the mounting bracket.
4. Remove discharge valve from the agent cylinder assembly, clean and examine all valve parts thoroughly and apply Amerex P/N 06247 Visilox lubricant to the collar o-ring.
5. Empty the agent cylinder of all remaining agent. Inspect the interior of the cylinder for residue (clean if necessary). Inspect cylinder threads for evidence of damage.
6. Fill the cylinder with proper charge of Amerex Kitchen Wet Chemical Agent:
 - Use Amerex P/N 16924 – 2.72 Gallon Recharge for 275 Agent Cyl.
 - Use Amerex P/N 12866 – 3.75 Gallon Recharge for 375 Agent Cyl.
 - Use Amerex P/N 17450 – 4.80 Gallon Recharge for 475 Agent Cyl.

WARNING:

RUBBER GLOVES AND SAFETY GLASSES SHALL BE WORN WHENEVER HANDLING AMEREX KP EXTINGUISHING AGENT. AVOID SKIN CONTACT. FLUSH WITH WATER FOR 15 MINUTES IF CONTACT OCCURS. DO NOT INGEST. IF AGENT IS INGESTED, DILUTE WITH MILK OR WATER AND CONTACT A PHYSICIAN IMMEDIATELY. CONSULT THE MATERIAL SAFETY DATA SHEET.

7. Inspect valve and stem assembly for deterioration or wear. Replace if required. Install valve assembly and downtube into the cylinder.
8. Attach the recharge adapter (P/N 09492) to the valve discharge port.
9. Attach the “T” handle recharge adapter (P/N 12855) to the top of the discharge valve.

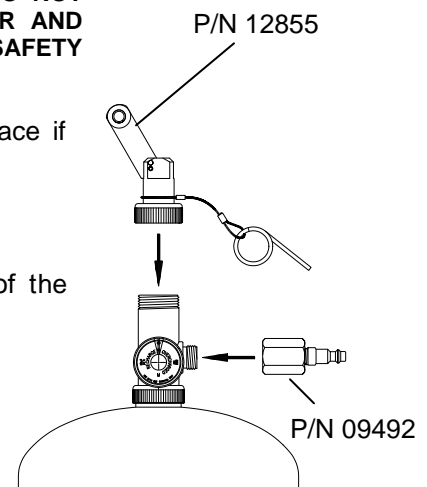
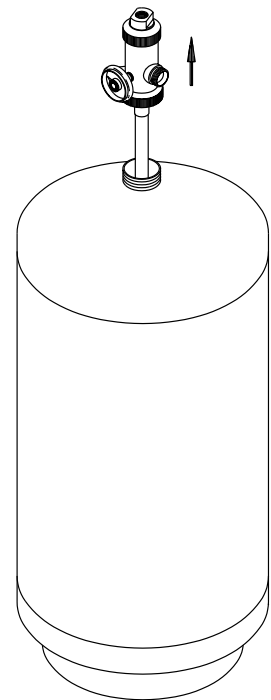

RECHARGE PROCEDURES (Model 600 CYLINDER)**WARNING:**

BEFORE ATTEMPTING ANY RECHARGE PROCEDURES, FIRST CONFIRM THE REASON FOR THE DISCHARGE AND CORRECT ANY CONDITIONS THAT CAUSED THE SYSTEM TO DISCHARGE. THE AMEREX KP RESTAURANT FIRE SUPPRESSION SYSTEM MUST BE RECHARGED IMMEDIATELY AFTER ANY DISCHARGE REGARDLESS OF THE CAUSE FOR DISCHARGE. IF RECHARGE CANNOT BE ACCOMPLISHED IMMEDIATELY DO NOT LEAVE THE SYSTEM INCAPACITATED FOR ANY REASON WITHOUT GIVING WRITTEN NOTIFICATION TO THE OWNER, OWNER'S AGENT, LOCAL AHJ AND DOCUMENTING THE INCIDENT IN THE PERMANENT JOB FILE. ANY SYSTEM COMPONENTS SUBJECTED TO FIRE OR OVERHEATING CONDITIONS MUST BE REPLACED, INCLUDING BUT NOT LIMITED TO CYLINDERS, BRACKETS, DETECTORS, NOZZLES, PIPING, CONDUIT CABLE.

1. Relieve all pressure in the actuation line by depressing the ball check in the vent check or loosening a fitting.

WARNING: ENSURE THAT ALL PRESSURE HAS BEEN RELIEVED FROM CYLINDER BEFORE PROCEEDING.

2. Slowly remove pneumatic actuator assembly from the agent cylinder valve assembly.
3. Remove discharge valve from the agent cylinder, clean and examine all valve parts thoroughly and apply Amerex P/N 06247 Visilox lubricant to the collar o-ring. Replace worn or suspect parts. Replace valve stem o-rings.
4. Empty the agent cylinder of all remaining agent. Inspect the interior of the cylinder for residue (clean if necessary). Inspect cylinder threads for evidence of damage.
5. Fill the cylinder with proper charge of Amerex Kitchen Wet Chemical Agent. Use Amerex P/N 15416 – 6.14 Gal. Recharge (model 664).

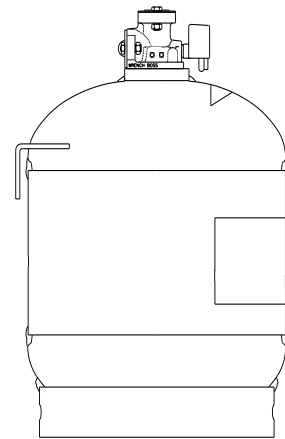
**WARNING:**

RUBBER GLOVES AND SAFETY GLASSES SHALL BE WORN WHENEVER HANDLING AMEREX KP EXTINGUISHING AGENT. AVOID SKIN CONTACT. FLUSH WITH WATER FOR 15 MINUTES IF CONTACT OCCURS. DO NOT INGEST. IF AGENT IS INGESTED DILUTE WITH MILK OR WATER AND CONTACT A PHYSICIAN IMMEDIATELY. CONSULT THE MATERIAL SAFETY DATA SHEET.

6. Install valve assembly and downtube into the cylinder.
7. Attach the recharge adapter (P/N 10136) to the valve discharge port.
8. Attach the "T" handle recharge adapter (P/N 10134) to the top of the discharge valve.
9. Connect the recharge adapter to a regulated source of nitrogen, set at 240 +25 psi (1655 kPa) and pressurize the cylinder using the "T" handle adapter to depress the valve stem. When the agent cylinder is pressurized to 240 psi @70°F (1655 kPa @21°C), agitate the cylinder for a period of one minute and check the pressure gauge, add more nitrogen if necessary. Confirm proper pressurization by using a calibrated gauge at the low pressure side of the regulator.
10. Remove the recharge adapter and "T" handle adapter.
11. a) **275 / 375 / 475** Agent Cylinder – attach the actuation port connection
12. b) **600** – install pneumatic actuator.

Note: Reset Pneumatic Actuator P/N 15157 before installation. - DISCONTINUED

- i. Remove the large retaining ring from the bottom of the Control Head (Figure 1).
- ii. With a 5/32" Allen wrench (or smaller) inserted through the cross-drilled hole in the tapered piston, pull the piston assembly out of the control head body (Figure 1).
- iii. The thin circular disk and the small spiral retaining ring (replacement p/n 14037) must be removed from the piston assembly. To do this, with the Allen wrench, unscrew the small tapered piston from the large brass piece (Figure 2). Do not use a vise, as this could damage the part.
- iv. Once the small tapered piston is removed, simply slip the thin circular disk and the small spiral retaining ring off the back end (Figure 2).
- v. Re-assemble the Control Head, as shown in Figure 3. First, tighten the small tapered piston back onto the large brass piece. Make sure that it bottoms onto the brass part, and is hand-tight with the Allen wrench. The piston assembly is to be pushed all the way into the control head body.
- vi. Hold the thick circular disk with the groove facing up (Figure 3). Drop the small spiral retaining ring into the groove.
- vii. The thin circular disk is to be placed over the thick circular disk, and the three components are to be inserted over the piston assembly (by holding the control head body inverted, as shown, it is easier to insert the parts) (Figure 3).
- viii. With all of the components in place, and the small spiral retaining ring visible and loosely held between the two plates, reinstall the large retaining ring to hold the assembly together (Figure 3)

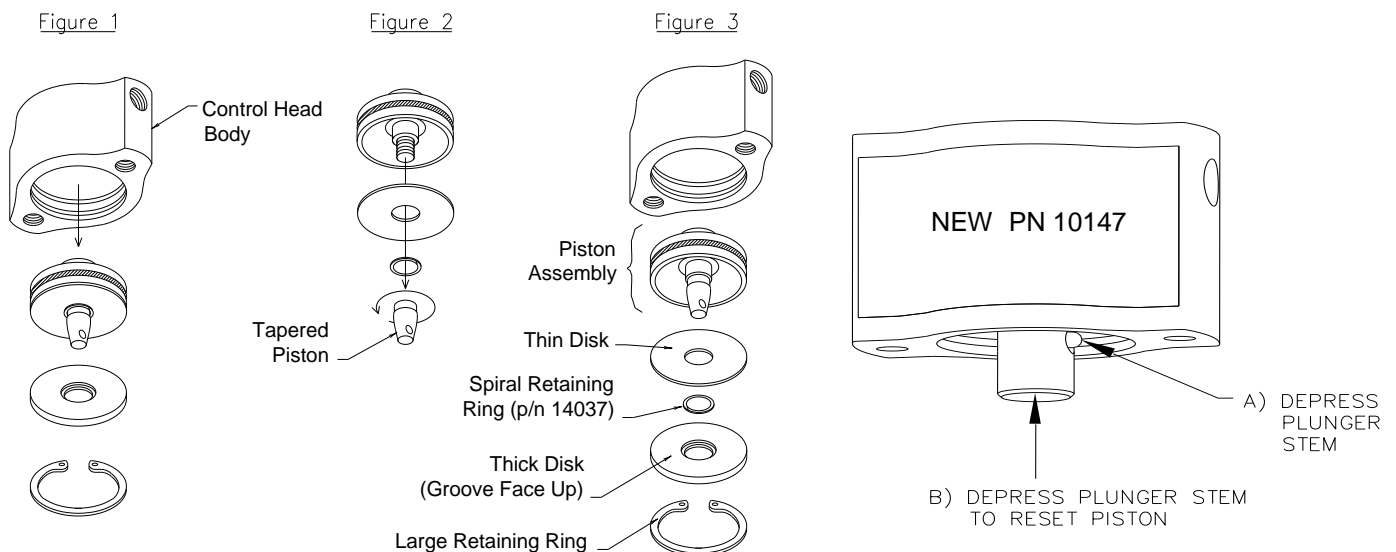
**OLD STYLE PNEUMATIC ACTUATOR PN 15157****Note: Reset Pneumatic Actuator P/N 10147 before installation.**

- i. Unbolt the Pneumatic Control Head from the Agent Cylinder Discharge Valve.
- ii. The piston of the control head will be locked in the "fired" position, and it must be reset.
- iii. To reset the control head, use a small flat tool to depress the small plunger ball on the side of the extended brass piston while simultaneously pushing the piston back into the head.
- iv. Do not attempt to unscrew the small plunger from the brass piston.
- v. The piston should be pushed back into the fully retracted position while depressing the plunger ball. See the following image:

13. Check the valve outlet, top chamber and collar for leaks using a leak detection fluid (soapy water). Bubbles may take several minutes to appear. Blow dry and clean all surfaces and orifices following leak detection.
14. If the agent cylinder assembly is **not** going to be placed into the bracket immediately or is going to be transported, **make sure that the anti-recoil and safety plates are in place and required labeling and securement is used.**
15. Follow all reset procedures and conduct a full functional test of the system.
16. If the discharge was caused by a fire incident, replace **ALL** of the fusible links in the detection network.
17. Remove all nozzles from the distribution piping network and clean thoroughly with warm soapy water, making sure that each nozzle is returned to its proper location. Replace any nozzles that appear to be damaged.
18. Flush the distribution piping network with water and blow clean using a regulated source of nitrogen connected to the distributor network test adapter. Set regulator for 150 PSI (10.342 bar). Secure the nitrogen cylinder when performing this test to prevent damage occurring to the cylinder, valve or regulator.
19. Install a full charged nitrogen actuation cylinder. **See below.**
20. After all functional testing, reset procedures, nozzle and blow off caps are replaced (if high temperature caps are used – replace nozzle tip o-rings if necessary), connect the actuation piping to the port(s) on top of the valve(s), install all new tamper seals and record all procedures in the permanent job file.

NITROGEN CYLINDER RECHARGE:

If you prefer to shop or field recharge Amerex nitrogen cylinders, either one of the two cylinder restraining devices pictured on Page 7 – 7 are recommended.

WARNING: NITROGEN ACTUATION CYLINDERS OPERATE AT EXTREMELY HIGH (1800 PSI) PRESSURES. HANDLE WITH CAUTION. PERFORM ALL RECHARGING WITH CYLINDERS RESTRAINED BY AN AMEREX APPROVED SUITABLE SAFETY SECURING DEVICE.

1. Remove nitrogen cylinder from MRM or PRM. Install shipping cap on N₂ cylinder.
CAUTION: UNSCREW THE NITROGEN CYLINDER SLOWLY TO ALLOW ANY RESIDUAL PRESSURE TO ESCAPE.
2. Clean the cylinder exterior to remove dirt, grease and foreign material. Check to make sure that the nameplate is in place and fully legible. Inspect cylinder for corrosion, abrasion or dents. If integrity of the cylinder has been compromised, make sure all pressure has been relieved and destroy.
NOTE: When cleaning N₂ cylinders, avoid use of solvents. Solvents could seriously damage the gauge face, the gauge guard or the nameplate.
3. Remove old rupture disc assembly:
 - a. Remove shipping cap and install cylinder in a P/N 10270 or 13430 N₂ Cylinder Recharge Adapter.
 - b. Hold cylinder in place using a 1-1/8 inch wrench on the hex portion of the N₂ cylinder fitting.
 - c. Loosen the rupture disc fitting by turning the Recharge Adapter Wrench ¼ turn.
 - d. If cylinder contains an unruptured disc, allow residual pressure to escape.
 - e. Unscrew cylinder from recharge adapter.
 - f. Unscrew old rupture disc assembly and DISCARD.

WARNING: NEVER REUSE A RUPTURE DISC, EVEN IF IT IS UNDAMAGED – DESTROY & DISCARD

4. Inspect sealing seat on rupture disc fitting. Discard N₂ cylinder if the seat is damaged.
 5. Install new rupture disc assembly (replace only with Amerex P/N 09958 rupture disc assembly – use of substitute parts will void the manufacturer's warranty).
 - a. Wipe sealing seat on N₂ cylinder rupture disc fitting and copper gasket on new rupture disc with a clean damp cloth.
 - b. Apply one drop of light machine oil to copper gasket on new safety disc and spread across entire gasket.
 - c. Screw disc assembly into fitting hand tight.
 6. Pressurize the N₂ cylinder
 - a. Install cylinder in P/N 10270 N₂ Cylinder Recharge Adapter.
 - b. Tighten cylinder by hand 1 to 1½ turns past contact with the sealing gasket.
 - c. Hold cylinder in place using a 1-1/8 inch wrench on the hex portion of the N₂ cylinder fitting.
 - d. Loosen the rupture disc 1/8 turn.
 - e. Connect a REGULATED nitrogen supply to the N₂ cylinder recharge adapter.
- NOTE: High pressure regulators are available from Getz Manufacturing, 1525 SW Adams Street, Peoria, IL 61602-1709. Phone (309) 674-1723 Fax: (800) 473-6088
- f. Slowly pressurize the N₂ cylinder to 1800 psi at 70°F.

NOTE: The nitrogen may experience a significant temperature rise as it compresses into the cylinder. The temperature rise must be compensated for by pressurizing to the valve corresponding to 1800 psi at the higher temperature. The best method to properly pressurize is to attach a commercially available magnetic base thermometer to the side of the N₂ cylinder. Pressurize and hold the cylinder at 1800 psi. (Make sure that there are no leaks in the nitrogen supply plumbing.) Let the apparatus sit undisturbed for 2 minutes minimum to allow the temperature to stabilize. Read the temperature on the thermometer. Refer to Temperature/Pressure chart on Page 7-8. Locate the temperature on the "Cylinder Temperature" (horizontal) axis of the graph. Draw a line vertically upward from that temperature until it crosses the "Nominal Pressure" line. Draw a second line horizontally from the point of intersection to the "Charge Pressure" (vertical) axis of the graph. Increase the pressure from the regulated nitrogen supply to match the valve read from the "Charge Pressure" axis of graph. Use only DRY nitrogen for pressurizing with a dew point of -70°F (-57°C) or lower.

- g. When the proper pressure is reached:
 - i. Tighten the rupture disc by applying a torque wrench to the recharge adapter and tighten (clockwise) to 40 foot pounds.
 - ii. Shut off nitrogen supply.
 - iii. Bleed and disconnect the supply hose.
 - iv. Remove nitrogen cylinder from the recharge adapter.
- h. Check for leaks using leak detect fluid (soapy water) to the rupture disc, the threads on the rupture disc fitting where it joins the cylinder and the pressure gauge threads. Bubbles may take several minutes to appear. Blow dry fluid from all surfaces and inside of the rupture disc following leak detect. Install shipping cap.

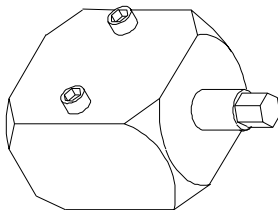

P/N 10270
Nitrogen Cylinder Recharge Adapter

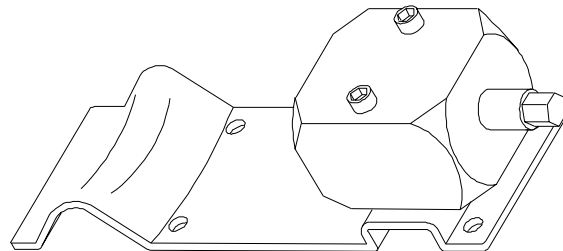

P/N 13430
Nitrogen Cylinder Recharge Adapter with
Restraining Bracket (Vehicle or shop
installation- either wall or bench)

N2 CYLINDER CHARGE PRESSURE
AS A FUNCTION OF
CYLINDER TEMPERATURE
(to obtain 1800 psig at 70°F)

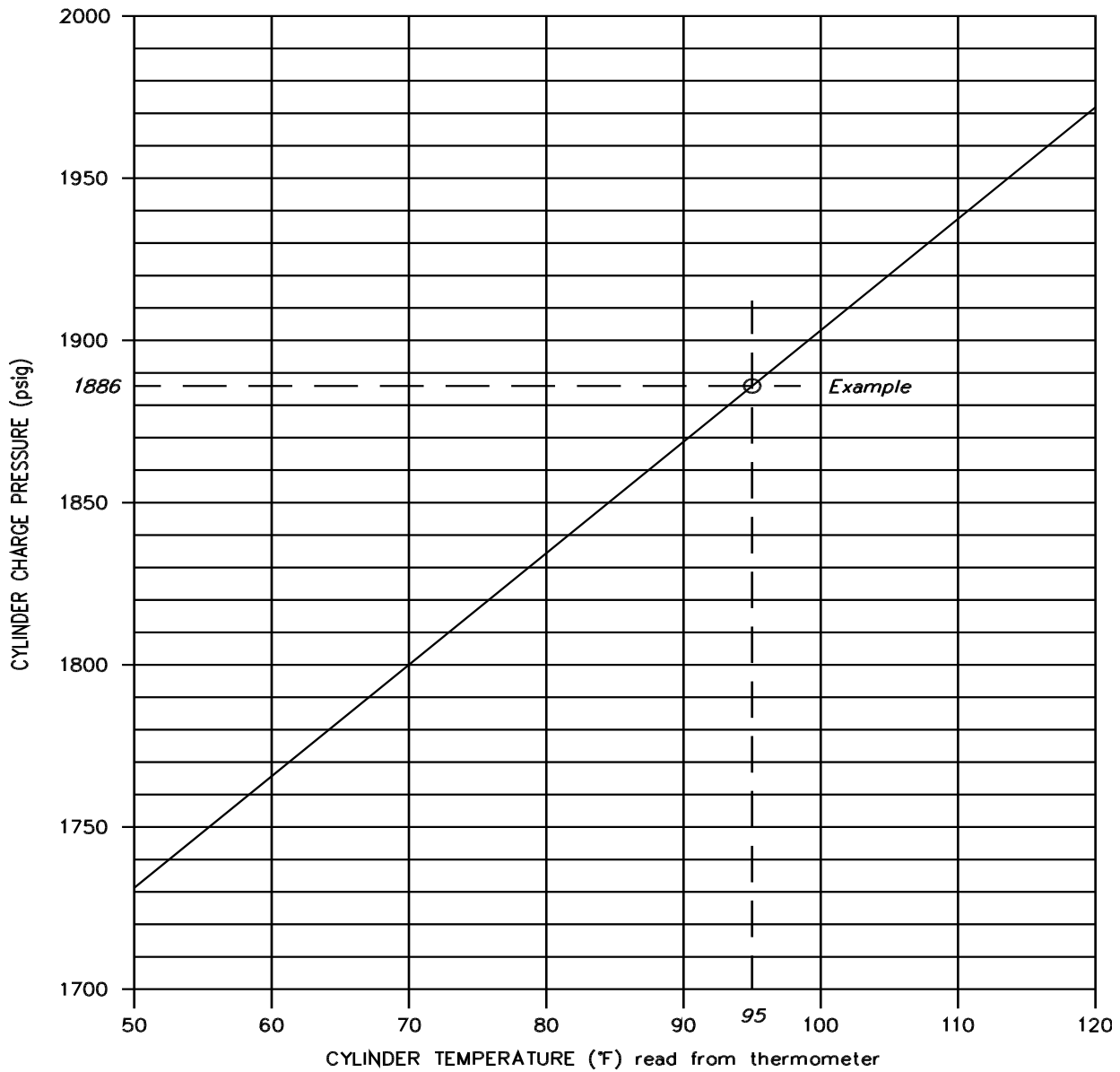
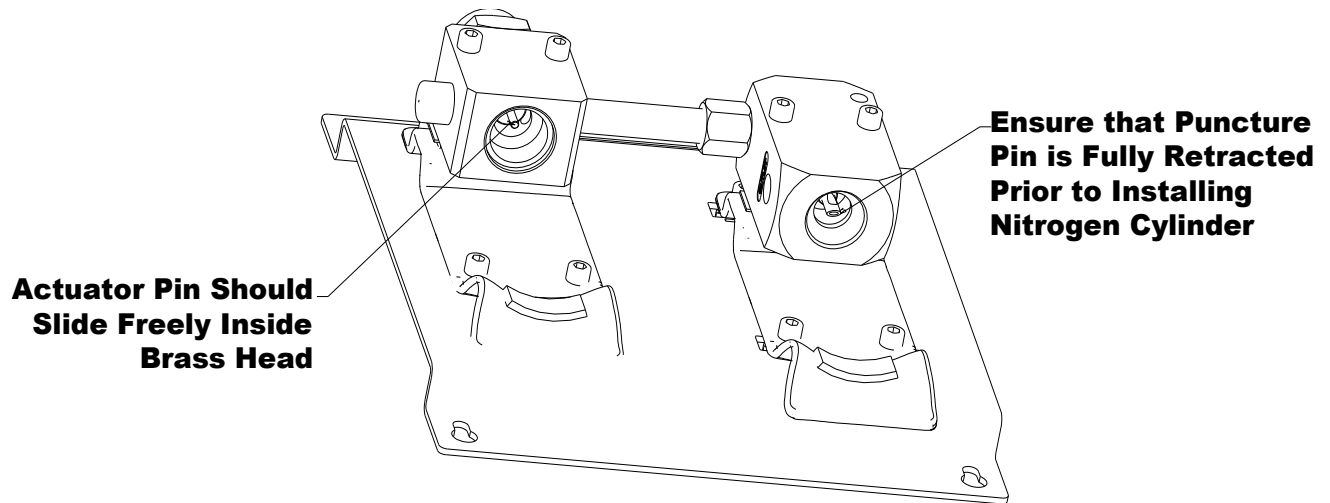

FIGURE 9.1

RESET PROCEDURES (ECH)

Each time the ECH is fired, the nitrogen cylinders must be removed and re-pressurized. The electric actuator (P/N17014) must be manually reset by pushing up the small pin until an audible click is heard. A blunt instrument, such as the back of a writing pen, may be used to reset the pin. When the nitrogen cartridges are removed, ensure that the smaller, sliding pin on the left of the assembly does not become dislodged. It must also remain free-sliding in the brass block. The puncture pin on the right side of the assembly must be fully retracted prior to re-installing the 15 in³ nitrogen cylinder.



Appendix A Special Application Guidelines

The information contained in this Section is exclusively for use in the protection of risks for which a **Loss Prevention Certification Board System Approval Label** is required.

Appendix A1:

The installation of a Deep Fat Fryer Nozzle PN13729 at a height lower than its listed minimum is only permitted if provisions are made to accommodate the resultant splashing of grease. This need may occur due to the low height of the hood provided over the appliance. In the event of such a situation precautions must be taken to prevent the splashing of the hot grease onto persons or flammable material located adjacent to the appliance. Any opening that would allow this to happen must be closed off by the installation of a guard of sufficient size to prevent the splashing. The required guard height above the appliance is limited to the size of the opening or 18" whichever is less. A guard higher than 18" is permitted but not required. This provision will then allow the nozzles to be located at a height less than the listed minimum. The lowest nozzle height is limited to 16" above the liquid level of the grease.

Extinguishment at this lower height is enhanced due to the increase of agent being applied directly to the burning grease and none being allowed to spray outside the appliance. A high degree of fire safety is achieved and public safety is preserved.

Appendix A2:

The term "Commercial" is used interchangeably with "Industrial" as it applies to cooking appliances. Both refer to the preparation of food for sale, with the primary difference being the quantity of food cooked and to whom the consumer is. None of those considerations are of any importance when it comes to fire suppression and safety.

APPENDIX A

MANUAL P/N: 20150

AMEREX RESTAURANT FIRE SUPPRESSION SYSTEM

**Tested and Listed By
The Loss Prevention Certification Board**



**Approved to I.P.S 1223
LPCB Ref. No. 407a/01**

December 2008

Appendix B Special Application Guidelines

The information contained in this Section is exclusive to the fire extinguishing system for the protection of galley deep fat fryers, located on board ships requiring DNV certification of a SOLAS 74 approved system tested in compliance with ISO – 15371 Fire Test Specification.

Appendix B1:

The installation of a Deep Fat Fryer Nozzle PN13729 at a height 36”- 48” located anywhere over the appliance and aimed at the center of the hazard will protect a Full Vat Deep Fat Fryer with a cooking area equal to the listing found on page 3-6 of the Amerex – “Design, Installation, Maintenance & Recharge Manual”, Part no. 12385 Rev. A.

Appendix B2:

The installation of a Deep Fat Fryer Nozzle PN13729 at a height 36”- 48” located anywhere over the appliance and aimed at the center of the hazard will protect a Split Vat Deep Fat Fryer with two cooking areas equal to 18” x 18” each. Refer to the drawing below for the optima positioning of the nozzles.

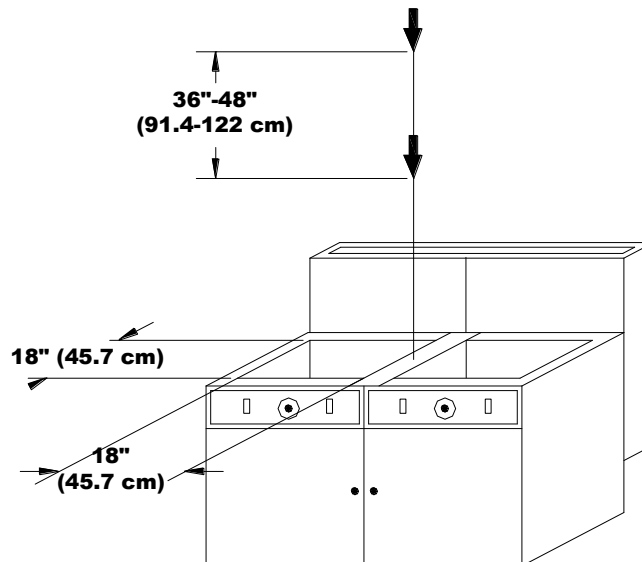

Distribution piping is to be stainless steel tubing. The following equivalent sizes are to be used in place of the standard pipe sizes:

3/8” pipe = 10mm minimum S.S. tubing with min. wall of 1.0mm

1/2” pipe = 16 mm minimum S.S. tubing with min. wall of 1.0mm

All other piping limitations, appliances, ducts and plenum coverage are contained within the body of the Amerex “Design, Installation, Maintenance & Recharge Manual”, Part no. 12385 Rev. A. Compliance with these limitations is required to provide a compliant fire extinguishment system.

APPENDIX B

MANUAL P/N: 20150

AMEREX RESTAURANT FIRE SUPPRESSION SYSTEM

**Certified to meet SOLAS 74 by DNV
Compliance Tested to ISO-15371**

December 2008



DET NORSKE VERITAS

EC TYPE-EXAMINATION CERTIFICATE

Application of: Council Directive 96/98/EC of 20 December 1996 on Marine Equipment as amended by directive 2008/67/EC, issued as "Forskrift om Skipsutstyr" by the Norwegian Maritime Directorate. This certificate is issued by Det Norske Veritas under the authority of the Government of the Kingdom of Norway.

CERTIFICATE NO. **MED-B-5506**

This is to certify that the
Deep fat cooking equipment fire extinguishing systems components (automatic or manual type)

with type designation(s)
Amerex KP Fire Suppression System KP 375

Manufacturer
Amerex Corporation
Trussville, United States

is found to comply with the requirements in the following Regulations/Standards:
Annex A.1, item No. A.1/3.43 and Annex B, Module B in the Directive. SOLAS 74 as amended, Regulation II-2/1, II-2/10 & X/3 and 2000 HSC Code 7

Further details of the equipment and conditions for certification are given overleaf.

Høvik, 2009-09-02
for Det Norske Veritas AS

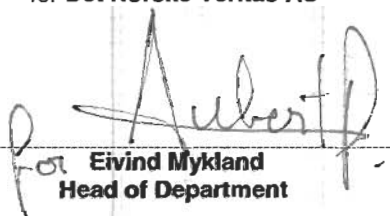

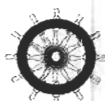
For **Eivind Mykland**
Head of Department



Notified Body No.: **0575**

DNV local office:
DNV New Orleans

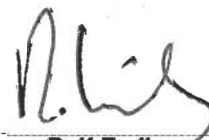
This certificate is valid until
2014-09-02

Rolf Emilsen
Surveyor



Notice: The certificate is subject to terms and conditions overleaf. Any significant changes in design or construction of the product, or amendments to the Directive or Standards referenced above may render this certificate invalid. The product liability rests with the manufacturer or his representative in accordance with Council Directive 96/98/EC, as amended.
The Mark of Conformity may only be affixed to the product and a Declaration of Conformity may only be issued when the production/product assessment module referred to in the council directive, is fully complied with.



Certificate No.: MED-B-5506
Item No.: A.1/3.43
Job Id.: 344.1-000671-3

The following documents are to be approved and filed by the Flag State Administration:

- System arrangement plans including location and specification of cylinders, nozzles, sections valves, release stations and control arrangement.
- Shut down of function defined by SOLAS Ch. II-2, Reg.10, 6.4.2 – 6.4.5.
- Manual containing operating and maintenance instructions

Installation testing:

Pressure testing of pipe system to at least 1.5 times maximum working pressure. Testing according to maker's manual.

Periodical testing:

Periodical control and inspection is to be in accordance with makers manual.

Each system is to be supplied with its manual for installation, use and maintenance.

Type Examination documentation

Amerex design, installation, maintenance and recharge manual No. 12385 Rev. A. dated October 2003 and Appendix B dated May 2004.

Component drawings as mentioned above.

Fire Performance Test Reports: No. PE 100016, Serial Nos 9609 and 9610 dated 7 June 2004 from DIFT, Denmark

Tested according to ISO 15371.

Marking of product

The spray nozzle is to be marked with type designation whereas control unit is to be marked with name of manufacturer and type designation and Mark of Conformity (see below)

Mark of Conformity

The manufacturer is allowed to affix the Mark of Conformity according to Article 11 in the Council Directive 96/98/EC on Marine Equipment and shall issue a Declaration of Conformity, only when the module D or E or F of Annex B in the same directive is fully complied with.

Module D: The quality system for production and testing shall be approved by the Notified Body.

Module E: The quality system for inspection and testing shall be approved by the Notified Body.

Module F: Compliance of the products to type as described in this EC Type-Examination Certificate must be verified by the Notified Body who also shall issue a of Certificate Conformity.





Certificate No.: MED-B-5506
 Item No.: A.1/3.43
 Job Id.: 344.1-000671-3

Product description

“Amerex KP Fire Suppression System KP 375”

fire extinguishing system consists of spray nozzles, piping, section valves (as applicable), cylinders and a mechanical release module. The system is a pressure vessel system.

The deep – fat cooking protection system should be designed according to new SOLAS Ch. II-2, Reg.10, 6.4.1 - .5. This certificate addresses only item Reg. 10, 6.4.1. Compliance with the shut down function has to be verified in each case.

Applications/Limitations

The system shall be installed according to the below specification:

Spray nozzle, cylinders, piping, extinguishing agent etc.	
Part	Drawing No. , Description
Nozzle FR GR 2xFG W/Cap KP	13729 Rev. A CO-GT5 (Data Sheet)
Material	Spray nozzle: Brass, body to be chrome plated.
Cylinder KP375 with valve	16338 Rev. J, 13325 Rev. R 12284 Rev. X (valve)
Nitrogen Cylinder	12586 Rev. C
Mechanical release module	11977 Rev. B/C'
Piping diameter dimensions	Min. 10 mm. Only stainless steel to be used (to avoid clogging). Galvanized pipe is not allowed
Extinguishing agent Type: Premixed agent	KP Agent Model 544 Recharge Mixture of potassium acetate and water

Definition: a vat is the heating unit containing the oil.

The system is designed to cover two different hazards: single vat and split vat. The wet chemical extinguisher agent supply is pressurized gas based. The system is assembled by cylinder, piping and spray nozzles according to the below tables.

Alternative 1: Single Vat Deep Fat Fryer	
A spray nozzle 13729 is to be installed according to the installation manual, one nozzle is to be located over each Deep Fat Fryer, a maximum of five 13729 nozzles per each KP 375 Cylinder system.	
Vertical distance from vats:	Min. 914 mm Max. 1220 mm
Max. size of vat	460 x 460 x 310 mm
Drip board	460 x 100 x 70 mm
Drawings, assembly	Amerex manual 12385 rev. A
Operation pressure (cylinders):	15 bar

Alternative 2: Split Vat Deep Fat Fryer	
A spray nozzle 13729 is to be installed according to the installation manual, one nozzle is to be located over each Deep Fat Fryer, a maximum of five 13729 nozzles per each KP 375 Cylinder system	
Vertical distance from vats:	Min. 914 mm Max. 1220 mm
Max. size of each vat	460 x 460 x 310 mm
Drip board	460 x 100 x 70 mm
Distance between vats	Max. 56 mm.
Drawings, assembly	Amerex manual 12385 rev. A
Operation pressure (cylinders):	15 bar

For both systems

- For MED approval the cylinders and valve have to be approved according to the Pressure Equipment Directive 97/23/EG minimum model B + C1.
- System components, such as pipes, pipe connections are to be certified or inspected in accordance with DNV Rules or equivalent standards acceptable to the Flag State.
- Welding of pipes to be in accordance with DNV Rules.





Cert. No.: **MED-D-659**
Case No.: EC-FP-61/344.1-
000671
File No.: A.1/3.43

APPENDIX, REV. NO. 1

QS - Certificate of Assessment - EC, Certificate No. MED-D-659

<i>Product designation</i>	<i>EC Type-Examination Cert. No.</i>	<i>Expiry date</i>	<i>DNV QS Assessment Report dated</i>
Amerex KP Fire Suppression System KP 375	MED-B-5506	2014-09-02	2008-04-16

The manufacturer complies with the Council Directive 96/98/EC on Marine Equipment and is allowed to affix the Mark of Conformity followed by the DNV identification number 0575 and the two last digits of the number of the year in which the product is produced.

Example:  0575/09

The manufacturer shall issue a Declaration of Conformity for each product with reference to the EC Type-Examination Certificate and this QS – Certificate of Assessment – EC.

Place and date
Høvik, 2009-09-02

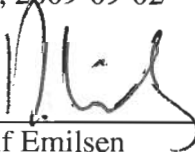
Rolf Emilsen
Surveyor



MSDA SHEET

KITCHEN WET CHEMICAL AGENT

FOR

**AMEREX RESTAURANT
FIRE SUPPRESSION SYSTEM**

**Tested and Listed by
Underwriters Laboratories, Inc.
to UL Standard 300
EX 4658**

**Tested and Listed by
Underwriters Laboratories of Canada
to UL/ORD 1254.6-1995**

December 2008

MATERIAL SAFETY DATA SHEET

Section 1. Chemical product and company identification

Product Name: KP SYSTEM WET CHEMICAL AGENT
(CH547, CH656, CH664 and CH 544)
Manufacturer: AMEREX CORPORATION
Internet Address: www.amerex-fire.com
Address: 7595 Gadsden Highway
P.O. Box 81
Trussville, AL 35173-0081
Telephone: (205) 655-3271
Emergency Contacts: Chemtrec 1(800) 424-9300 or
(703) 527-3887
Revised: March, 2006

Section 2. Hazard identification and emergency overview

Emergency overview: Reddish colored liquid.

Adverse health effects and symptoms: Mildly irritating to the eyes, skin, and respiratory system. Symptoms may include coughing, shortness of breath, and eye and skin irritation. Ingestion, although unlikely, may cause gastrointestinal disturbance.

Exposure guidelines:

Ingredients	OSHA PEL	ACGIH TLV	DFG MAK *
Water	NR**	NR	NR
Potassium acetate	NR	NR	NR
Potassium citrate	NR	NR	NR
Proprietary organic phosphate esters	NR	NR	NR
Example: Phosphoric acid tributyl ester	5 mg/m ³	2.2 mg/m ³	NR
Pink pigment	NR	NR	NR

*German regulatory limits ** NR = Not Regulated

Hazard symbols: WHMIS (Canadian workplace hazardous materials identification system)

D2B – Product may irritate skin or mucous membranes

Section 3. Composition/information on ingredients

Name/Compound	Weight %	CAS #
Water	< 50	7732-18-5
Potassium acetate	< 50	127-98-2
Potassium citrate	< 5	866-84-2
Organic phosphate esters	< 5	68130-47-2
Example: Phosphoric acid tributyl ester		126-23-8
Pink pigment, mono azo dyes	<1	3520-42-1 4478-76-6 6844-74-2

Section 4. First Aid Measures

Eye Exposure: Irrigate eyes at eye wash station for 15 minutes and repeat until pain free. Seek medical attention if irritation develops or persists, or if vision changes occur.

Skin Exposure: In case of contact, wash with plenty of soap and water. Seek medical attention if irritation develops or persists.

Inhalation: If respiratory irritation or distress occurs remove victim to fresh air. Seek medical attention if irritation develops or persists.

Ingestion: If victim is conscious and alert, give 2-3 glasses of water to drink and on the advice of medical personnel induce vomiting. Seek immediate medical attention. Do not leave victim unattended. To prevent aspiration of swallowed product, lay victim on side with head lower than waist. If vomiting occurs and the victim is conscious, give water to further dilute the chemical.

Medical conditions possibly aggravated by exposure: Skin contact may aggravate existing skin disease. Chronic overexposure may affect blood cholinesterase levels and the central nervous system.

Section 5. Fire fighting measures

Extinguishing media: non combustible and non flammable – product is an extinguishing agent

Unusual fire/explosion hazards: in a fire this material may decompose, releasing oxides of phosphorus, carbon, and acetic acid (see Section 10).

Insensitive to mechanical impact or static discharge.

HMIS hazard ranking: health 1, flammability 0, reactivity 0, personal protective equipment: eye protection, gloves and appropriate skin protection (see Section 8)

Section 6. Accidental release measures

Large spills (one drum or more) should be addressed by hazardous materials technicians following a site-specific emergency response plan and trained in the appropriate use of PPE. Clean up released material using sorbent socks for containment, followed by sorbent material inside containment. If deemed necessary, wear full face APR or PAPR with organic vapor cartridges (Section 8). Bag and drum for disposal. If product is used and/or contaminated, for example if mixed with kitchen grease, use PPE and containment appropriate to the nature of the mixture. Handle and dispose of as a hazardous waste unless testing indicates otherwise. Decontaminate with detergent and water.

Section 7. Handling and storage

Avoid skin, eye, or respiratory exposure. Use appropriate PPE when handling or maintaining equipment, and wash thoroughly after handling (see Section 8). Keep product in original container or extinguisher. Contents may be under pressure – inspect for extinguisher rust periodically to insure container integrity. Do not mix with other extinguishing agents.

Section 8. Exposure controls/ personal protection

During the application of this product against fires, exhaust gases and the products of incomplete combustion (PICs) are the principal respiratory hazards. In the manufacture of extinguishers, automated systems and point source ventilation controls sufficiently minimize respiratory exposure. Employers and employees must use their collective judgment in determining occupational settings where the use of a respirator is prudent. The need for respiratory protection is not likely for short-term use in well ventilated areas.

Respiratory protection: use air-purifying respirator (APR) or powered air-purifying respirator (PAPR) with organic vapor cartridges/canisters for short term exposure, and supplied air/SCBA for high concentration or prolonged exposure.

Eye protection: wear chemical goggles.

Skin protection: use nitrile, latex, or similar gloves and coveralls. Good personal hygiene practices essential, such as avoiding food, tobacco products, or other hand-to-mouth contact when handling. Wash thoroughly after handling.

Section 9. Physical and chemical properties

Appearance: reddish colored liquid

Specific gravity: ~ 1.3

Solubility: soluble in water

Non –flammable

Flash point: none

Vapor pressure: < 10 mm Hg at room temperature

pH: approximately 8.5

Boiling point: ~ 300° F
No explosive or oxidizing properties

Section 10. Stability and reactivity

Stability: stable

Incompatibles: strong acids, strong oxidizers such as sodium hypochlorite (bleach), aluminum, polyurethane, and any wet, reactive material.

Decomposition products: heat of fire may release carbon dioxide, phosphorus oxide, and acetic acid.

Possibility of hazardous reactions: none

Section 11. Toxicological information

Acute toxicity: Potassium acetate LD₅₀ oral rat: 3250 mg/kg body weight
Phosphoric acid tributyl ester LD₅₀ oral rat: >1400 mg/kg body weight
Target organs in man: respiratory system, eyes, skin. This product is a mild irritant to epithelial tissue, and may aggravate dermatitis.
Ingestion may cause gastrointestinal injury. No information was found indicating the product causes sensitization.

Chronic toxicity: This product's ingredients are not considered as "probable" or "suspected" carcinogens by OSHA, IARC, or ACGIH.

Reproductive toxicity: This product's ingredients are not known to have reproductive or teratogenic effects.

Section 12. Ecological information

Ecotoxicity: weak environmental toxin, specific negative effects unknown.

Persistence/
Degradability: moderate biodegradation in soil, rapid photolytic degradation in air

Bioaccumulation: extent unknown

Mobility in soil: water soluble, slow to evaporate, may reach groundwater

Section 13. Disposal considerations

This product is not a RCRA characteristically hazardous or listed hazardous waste. Dispose of according to state or local laws, which may be more restrictive than federal laws or regulations. Used product may be altered or contaminated, creating different disposal considerations.

Section 14. Transportation information

This product is not a hazardous material under U.S. Department of Transportation (DOT) 49 CFR 172, and is not regulated by the DOT.

Section 15. Regulatory information

International Inventory Status Some ingredients are on the following inventories

Country(ies)	Agency	Status
United States of America	TSCA	Yes
Canada	DSL	Yes
Europe	EINECS/ELINCS	Yes
Australia	AICS	Yes
Japan	MITI	Yes
South Korea	KECL	Yes

European Risk and Safety phrases:

EU Classification: Xi. Irritant
R Phrases: 36 Irritating to eyes.
S Phrases: 26 In case of contact with eyes, rinse immediately with plenty of water and seek medical advice.
36 Wear suitable protective clothing.

U.S. federal regulatory information:

None of the chemicals in this product are under SARA reporting requirements or have SARA threshold planning quantities (TPQs) or CERCLA reportable quantities (RQs).

State regulatory information:

Chemicals in this product are not covered under specific State regulations, as denoted below:

Alaska - Designated Toxic and Hazardous Substances: None
California – Permissible Exposure Limits for Chemical Contaminants: None
Florida – Substance List: None
Illinois – Toxic Substance List: None
Kansas – Section 302/303 List: None
Massachusetts – Substance List: None
Minnesota – List of Hazardous Substances: None
Missouri – Employer Information/Toxic Substance List: None
New Jersey – Right to Know Hazardous Substance List: None
North Dakota – List of Hazardous Chemicals, Reportable Quantities: None
Pennsylvania – Hazardous Substance List: None
Rhode Island – Hazardous Substance List: None
Texas – Hazardous Substance List: No
West Virginia – Hazardous Substance List: None
Wisconsin – Toxic and Hazardous Substances: None

California Proposition 65: No component is listed on the California Proposition 65 lists.

Section 16. Other information

This MSDS conforms to requirements under U.S., U.K., Canadian, Australian, and EU regulations or standards, and conforms to the proposed 2003 ANSI Z400.1 format.

The information herein is given in good faith but no warranty, expressed or implied, is made.

The information herein is given in good faith but no warranty, expressed or implied, is made. Updated by Lindsay R. Hill, CIH.



Amerex Corporation

7595 Gadsden Hwy. Trussville, AL 35173 ❖ Ph: (205) 655-3271 ❖ Fax: 1-800-654-5980 ❖ e-mail: sales@amerex-fire.com

AMEREX PNEUMATIC RELEASE MODULE (PRM)

Simple, Fast Installation and Maintenance

- No corner pulleys
- No cable
- No crimps
- Tubing simply snaps into clips anchored every 18 inches
- No cutting and measuring of conduit within the hazard area
- No tension to “set”
- Tubing may be cut to length (no splices allowed)
- 3 year tubing replacement requirement
- Pressurized with compressed air (70 PSI) through standard air valve - no special tools required
- Testing accomplished by simply de-pressurizing the tubing
- Easy to clean during 6 month maintenance
- Accumulator pressure gauge can be viewed through window on PRM cover

Better Fire Detection

- Entire tubing run works as a detector
- In commercial kitchens, entire hood is covered with a single device
- No need to change detector locations if appliances change
- UL Listed for 435°F temperature response (375°F maximum intermittent safe exposure temperature with a maximum sustained ambient temperature of 176°F)
- Responds to actual fire as a “quick response” device
- Safe for use in Hazardous locations

Rugged, Durable and Reliable

- Impervious to hood cleaning chemicals, pressure washers
- Years of extensive testing conducted



(TUBING AND NITROGEN CARTRIDGE SOLD SEPARATELY)



(SHOWN WITH COVER)

The Amerex PRM detection system consists of the PRM, tubing and end of line fitting. The tubing is pressurized to 70 PSI through a small “accumulator” inside the enclosure, routed throughout the hazard area, and has a UL Listed fixed temperature. When exposed to a fire condition the tubing ruptures, relieving all of the pressure in the tubing and the accumulator thus firing a nitrogen cylinder to initiate system actuation.

The PRM comes complete with enclosure, accumulator, end of line fitting, connection for mechanical manual pull, two SPDT microswitches (pre-installed), mechanical gas valve capabilities and appropriate “knock-outs”. Additionally, a supervisory low-pressure switch is factory installed for use with the optional low-pressure LED module. Detection tubing is sold separately in 25ft., 50ft., 75ft., 150ft. and 300ft. lengths.

DETECTION TUBE ROUTING

Top View

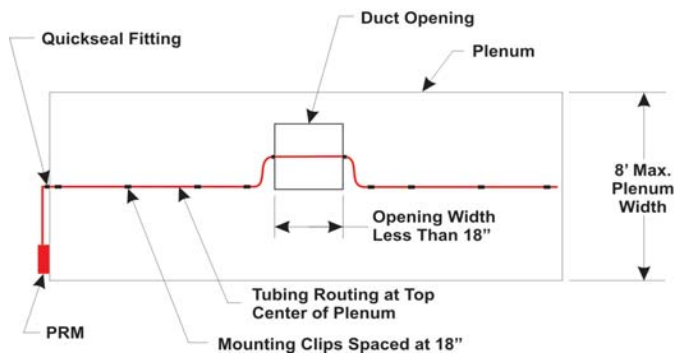

Top View

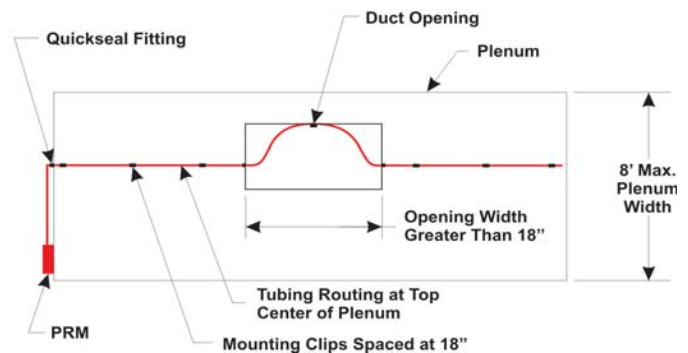

Part No. 17484

OPTIONAL LOW PRESSURE MODULE

Flashing LED indicator gives warning that pressure in the pneumatic detection line is below the minimum operating pressure. System should be serviced immediately to prevent un-wanted system discharge.

AMEREX CORPORATION
 7595 Gadsden Hwy. ❖ Trussville, AL 35173
 Phone: (205) 655-3271 ❖ Fax: 1-800-654-5980
 email: sales@amerex-fire.com
 web site: www.amerex-fire.com

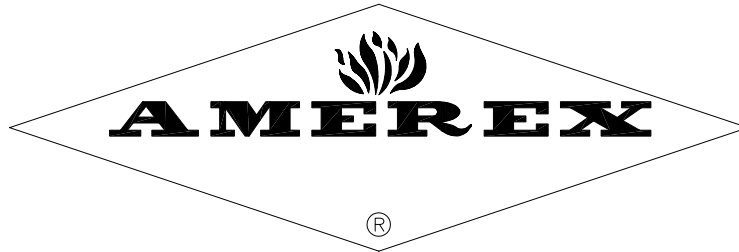

Pneumatic Release Module,
p/n 16547

DESIGN AND INSTALLATION MANUAL,
p/n 16546, Revision B, March, 2006

AMEREX CORPORATION INC. - 7595 GADSDEN HIGHWAY - TRUSSVILLE, AL 35173

Amerex Pneumatic Release Module

Installation, Operation and Maintenance Manual

For Use with Amerex Fire Suppression Systems

Features & Benefits

- Mechanical Releasing Unit Using Pressurized Detection Tubing
- No Detection Cable, Crimps, Conduit or Corner Pulleys Required
- Visible Trouble Indicator Visible Showing System Status
- Observation Windows for Nitrogen Actuation Cylinder and Detection Accumulator Pressures
- Tubing is Safe for Hazardous (Classified) Locations, Eliminating Electrical Isolation Requirement
- For Kitchen Systems, No Need to Change Detection Layout if Appliances are Moved
- 300 Foot Maximum Continuous Tubing Length, Secured by Snap-In Mounting Anchors
- Pressurized with Compressed Air or Nitrogen Through Standard Schrader Valve
- Automatic Linear Detection; 435° F (224° C) Temperature Response
- 375° F (190.5° C) Maximum Intermittent Safe Exposure Temperature, with a Maximum Sustained Ambient Temperature of 176° F (80° C).
- Capable of Supporting One or Two Manual Pull Stations
- Electrical or Mechanical Gas Valve Shut-Off Capable
- Delayed Discharge Actuation Capability with Optional Mechanical Time Delay
- Simple, Quick Six Month Test by De-Pressurizing Schrader Valve
- Two Dry Contact SPDT Microswitches Provided for Optional Auxiliary Use; Provisions for Two Additional SPDT Microswitches
- Auxilliary Pressure Switch Dry Contacts (SPST) Available for External Monitoring.

Approval

The Pneumatic Release Module (PRM) is UL /ULC Listed as a Heat Actuated Device for Special Applications (S7253) and is intended for use with the Amerex IS (Industrial Dry Chemical), KP or ZD (Restaurant Wet Agent) Fire Suppression Systems, only.

The use of the PRM should be reviewed and authorized by the local authority having jurisdiction (AHJ) before installation.

I) General:

This single hazard module supervises and controls one Fire Suppression System. Proven, rugged mechanical components are reliably set into motion with a simple pneumatic detection interface. The PRM is listed with Amerex IS Industrial, KP, and ZD Restaurant Pre-Engineered Fire Suppression Systems. The PRM meets the detection requirements of NFPA codes 96, 17, and 17A.

II) Installation:

Detection

The PRM has provisions for a single, continuous section of detection tubing. No splicing or “tee’s” allowed. There shall be only two tubing terminations: one at the accumulator assembly inside the PRM, and the other at the opposite end of the tubing, with the use of an End of Line Fitting (p/n 16506). **Install the tubing in areas where the maximum sustained ambient temperature does not exceed 176° F (80° C).** Exposing the tubing to random and infrequent temperature spikes up to (but not exceeding) 375° F (190.5° C) is acceptable.

A properly designed commercial kitchen hood meeting the requirements of NFPA 96 should maintain temperatures above the filter bank well below 176° F (80° C). However, areas above certain high-heat appliances such as (but not limited to) upright broilers, solid fuel appliances, or charbroilers can reach and maintain temperatures above 176° F (80° C). Other factors, such as a low hood height over the appliances, can lead to elevated ambient temperatures. The use of baffles to redirect exhaust flue gasses from direct impingement on the tubing might be necessary, but may not always be effective. Installation of the tubing into areas beyond the temperature maximum may shorten the useful life of the tubing and require a more frequent replacement interval. Therefore, a thorough operating temperature survey **MUST BE** conducted in all applications prior to installation of a PRM to determine its suitability.

The Amerex part numbers for tubing lengths are:

<u>P/N</u>	<u>Length</u>
16557	25'
16551	50'
16556	75'
16552	150'
16554	300'

Tubing may be cut down to the required length, or be coiled up and secured with wire ties outside the hazard area. Cuts must be square and clean. The minimum bend radius is 6 inches, as illustrated below:

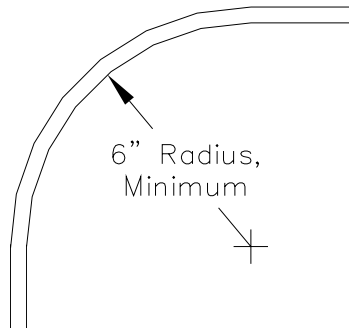

Do not crimp or crush the tubing in the course of handling or installation. Also, ensure that the tubing is not exposed to sharp edges or acidic chemicals. A Tubing Clip (p/n 16501) is required at least every 18” of tubing. A Tubing Clip is also required within one inch of the End of Line Fitting. A Quickseal Fitting serves the same function as a Tubing Clip, when passing through an opening. The tubing can exit the PRM panel either through the 5/8” hole at the upper right hand corner of the enclosure or it can exit through the 5/8” hole at the top right side of the enclosure. Insert the black plastic plug into the unused exit hole.

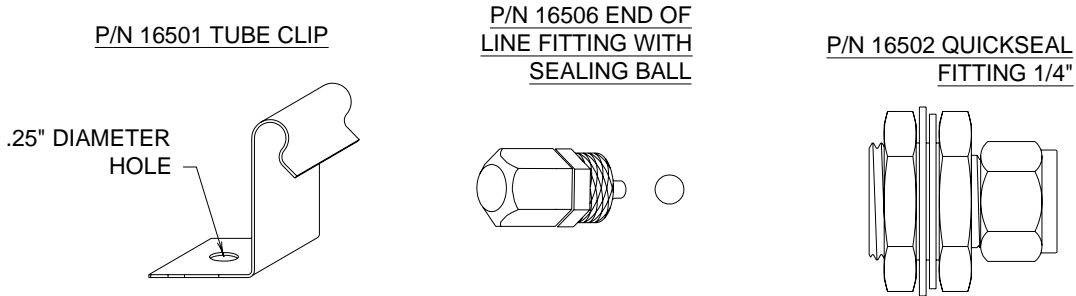

The p/n 16502 Quickseal Compression Fitting is required for kitchen hood and other penetrations requiring a UL-listed sealing device.

Warning: When tightening the nut on the p/n 16502 Compression Fitting, use a **MAXIMUM** of ½ turn past hand tight. Wrenching the nut past ½ turn can begin to collapse the detection tubing.

Care must be taken when terminating the start and end of the tubing to ensure leak proof connections. The following are instructions for termination:

Tubing Termination at the PRM:

- 1) Remove knurled nut from plated tube fitting and slide over end of tubing. The end of the tubing must be cut square and clean. **DO NOT** use pliers or wire cutters for cutting the tube. These tools will collapse the end of the tubing and could create a leak point. The use of the Amerex p/n 16860 Tubing Cutter is required. Do not use any sealants on the connection.
- 2) **Firmly** push the end of the tube down over the end of the fitting. If necessary, the use of a heat gun (placed on its lowest setting) may be used to warm the end of the tubing prior to pushing it on the fitting. Do not exceed 176° F (80° C) at the tubing, and only warm approximately one inch of the tubing end. It is important that the end of the tubing be inserted **ALL** the way over the tip of the fitting and firmly bottoms at the base of the fitting. (See the following figure). Hold the tubing in place **firmly** in one hand while tightening the nut with the other. Use a 12mm wrench (or adjustable) to tighten the nut. Resistance will be felt when the nut bottoms out. **Do not over tighten.**

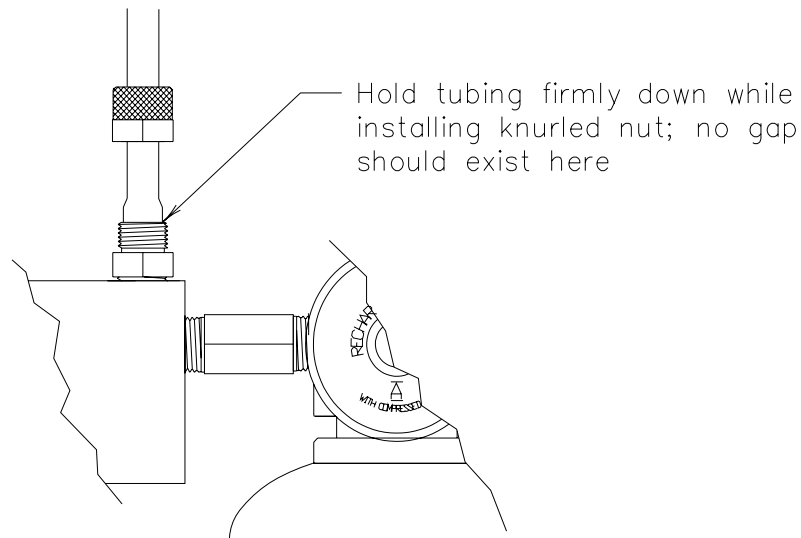

Tubing Termination at the End of Line (EOL):

- 1) Remove knurled nut from End of Line fitting and slide over the end of the tubing. The end of the tubing must be cut square and clean. **DO NOT** use pliers or wire cutters for cutting the tube. These tools will collapse the end of the tubing and could create a leak point. The use of the Amerex p/n 16860 Tubing Cutter is required. Do not use any sealants on the connection.
- 2) Flare the end of the tubing slightly with the tip of the fitting. Insert the p/n 17109 black Sealing Ball into the flared end of the tubing. **Firmly** push the end of the tube down over the end of the fitting, pushing the ball into the tubing. If necessary, a heat gun (placed on its lowest setting) may be used to warm the end of the tubing prior to pushing it onto the fitting. Do not exceed 176° F (80° C) at the tubing, and only warm approximately one inch of the tubing end. It is important that the end of the tubing be inserted **ALL** the way over the tip of the fitting. It may be helpful to place the End of Line Fitting in a small vise while pressing the tubing into position. Hold the tubing in place **firmly** with one hand while tightening the nut with the other. Use a 12mm wrench (or adjustable) to tighten the nut (See the following figure). Resistance will be felt when the nut bottoms out. **Do not over tighten.**

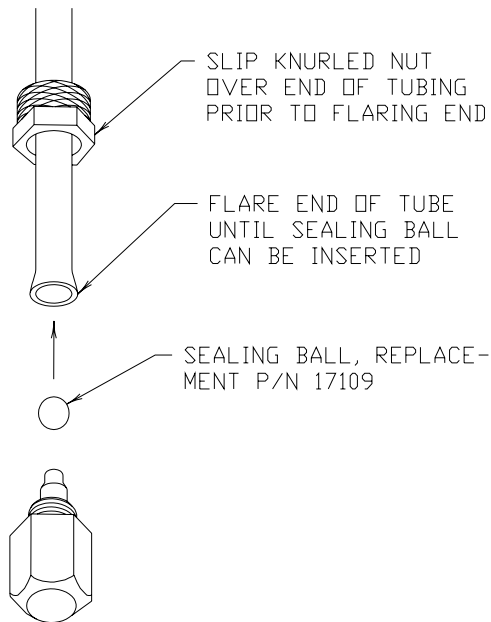

CAUTION: The small sealing ball, p/n 17109, is **ONLY** used at the End of Line Fitting, and must **NEVER** be used at the fitting inside the PRM.

Once the system is pressurized and put into service, both connections should be thoroughly leak checked with a commercial leak check fluid, such as that used in the natural gas industry. Record the date of tubing installation on the tubing replacement label on the accumulator cylinder, and affix the label to the detection accumulator cylinder as shown at the end of this section.

Warning: It is imperative that the field terminations be properly made. **YOU, the installer, are responsible for system functionality following installation and placing into service.** Failure to properly handle and terminate the tubing can result in air leakage, which will result in an unwanted system discharge. Allow **at least 20 minutes** for the leak check fluid to indicate any presence of leakage. **Even the smallest visible stream of bubbles can cause the system to lose pressure and discharge in just a few days.**

Securing the Tubing: The tubing must be secured at a distance not to exceed 18” with p/n 16501 Tubing Clips. A Tubing Clip is also required within one inch of the End of Line Fitting. Since the tubing snaps into the clip, it is recommended that the clips be installed first, then the tubing. Ensure that the tubing is routed in such a way as not to interfere with any moving parts or access openings. Tubing must not be obscured by structural or support structures, and should be fully exposed to any rising hot gasses, to ensure rapid detection response. Never take up slack by pulling the tubing through a series of clips, this action could damage the tubing and shorten its useful life.

Tubing Spacing Requirements:

IS Dry Chemical System Applications:

- 1) In large applications, in order to provide adequate fire detection, it may be necessary to form a “U” or “S” along the ceiling of the hazard. The maximum spacing between parallel runs of tubing must not exceed ten (10) feet. The tubing must be within four (4) feet and no less than two (2) feet from the adjacent wall.
- 2) Maximum Height Limitations:

Type of IS Coverage	Maximum Installed Ceiling Height*
Total Flood	16 feet
Vehicle Paint Spray Booth	16 feet
Open Front Paint Spray Booth	12 feet
*It is not required to reduce the spacing for high ceilings	

See the following IS examples of tubing routing on smooth, flat ceilings:

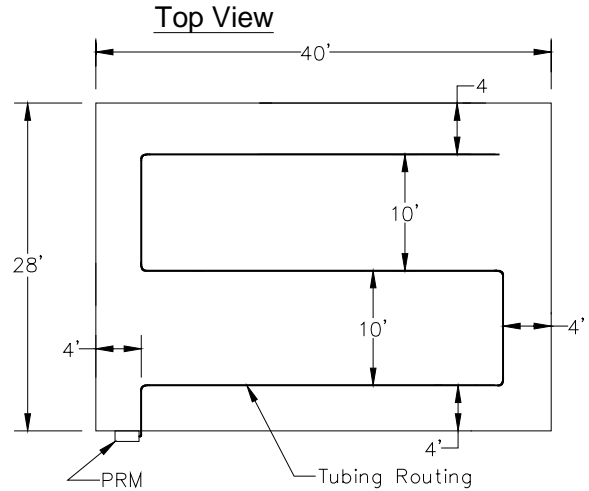
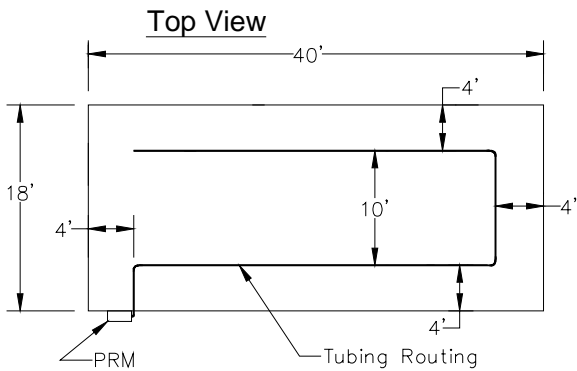
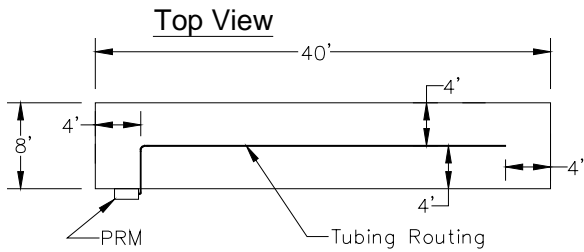

Tubing Spacing Requirements (continued):

Restaurant Kitchen Applications (KP or ZD):

- 1) The detection tubing is to be run at the top of the plenum, behind the filters, centered, from one end to the opposite end to ensure total detection coverage. The tubing must be secured at distances not to exceed 18" with p/n 16501 Tubing Clips. A Tubing Clip is also required within one inch of the End of Line Fitting. The tubing termination must be within six inches of the end of the hood. Ideally, the End of Line Fitting should be located as far forward in the hood as possible, out of any direct stream of hot appliance flue gasses, without penetrating the grease filters.

- 2) Additionally, the detection tubing is to cross over the plenum / duct opening at its center. When the opening width exceeds the 18” maximum mounting clip spacing, the tubing is to be installed in an ‘S’ pattern, so that the tubing makes at least one pass through the center of the plenum / duct opening. See the following figure:

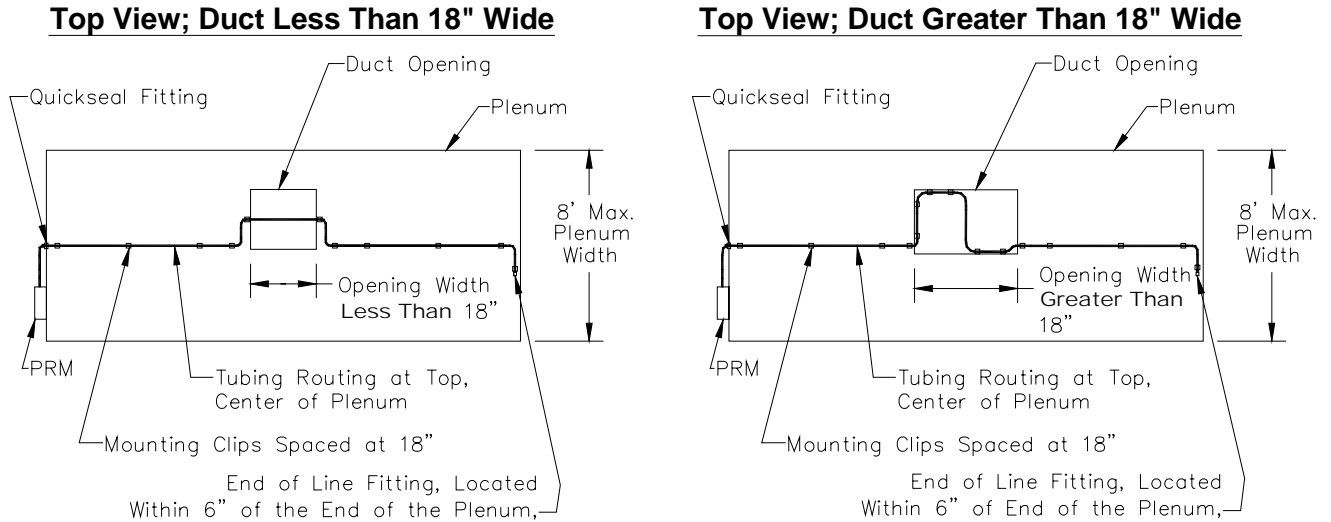

Manual Release

The PRM is capable of supporting one or two Manual Pull Stations (either the p/n 11993 or the p/n 14320 version). Refer to the appropriate Amerex KP, ZD, or IS Installation Manual for design limitations, installation, and servicing instructions of the manual pull station(s).

Auxiliary Microswitch

The PRM is supplied with two SPDT microswitches, pre-installed, and has the capability to support two additional microswitches. The microswitch is rated as shown below:

21 Amp 125, 250, or 277 VAC; 1 HP 125, 250, or 277 VAC; 2 HP 250, 277 VAC.

Uses of the microswitch include the shutdown of electrical appliances, such as an electric gas valve, or the exhaust fan of a paint booth. The following two illustrations show the wiring diagrams for the microswitch in electric gas valve and cooking appliance applications.

Electrical terminations must be made in UL-listed junction boxes outside the PRM.

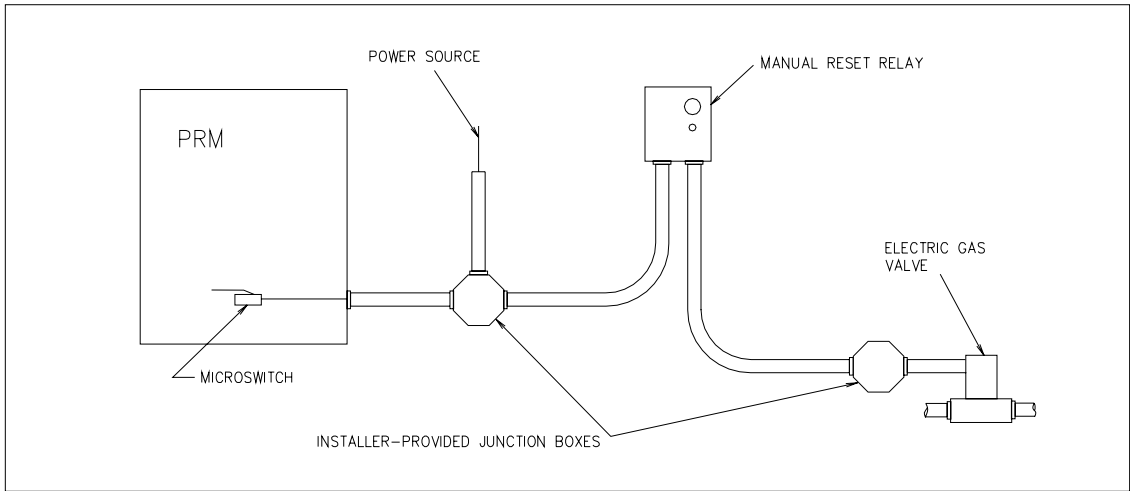

BASIC WIRING DIAGRAM

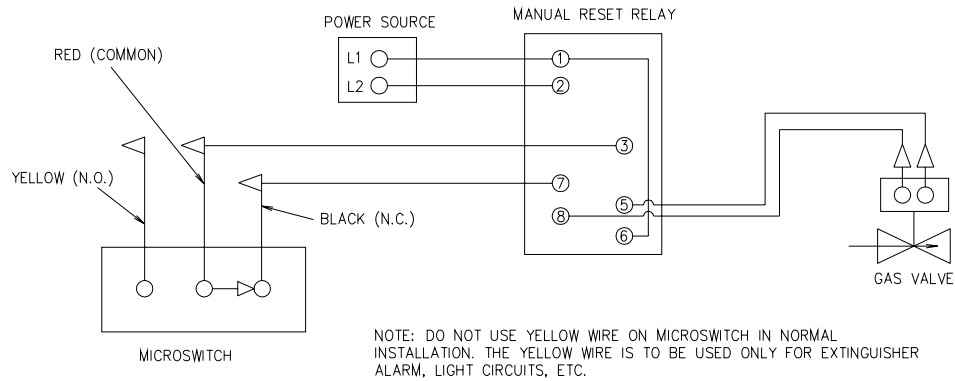

WIRING SCHEMATIC

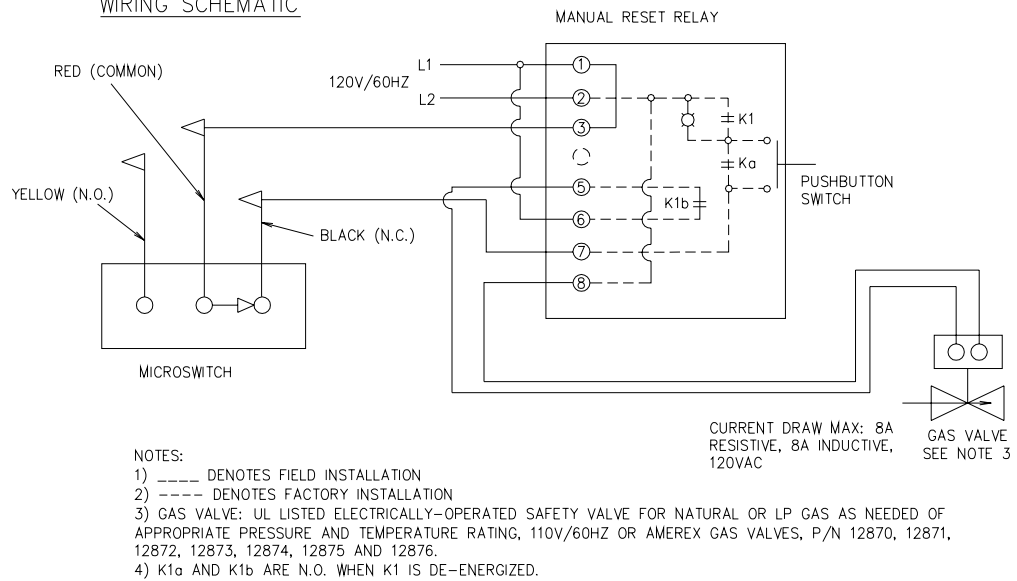

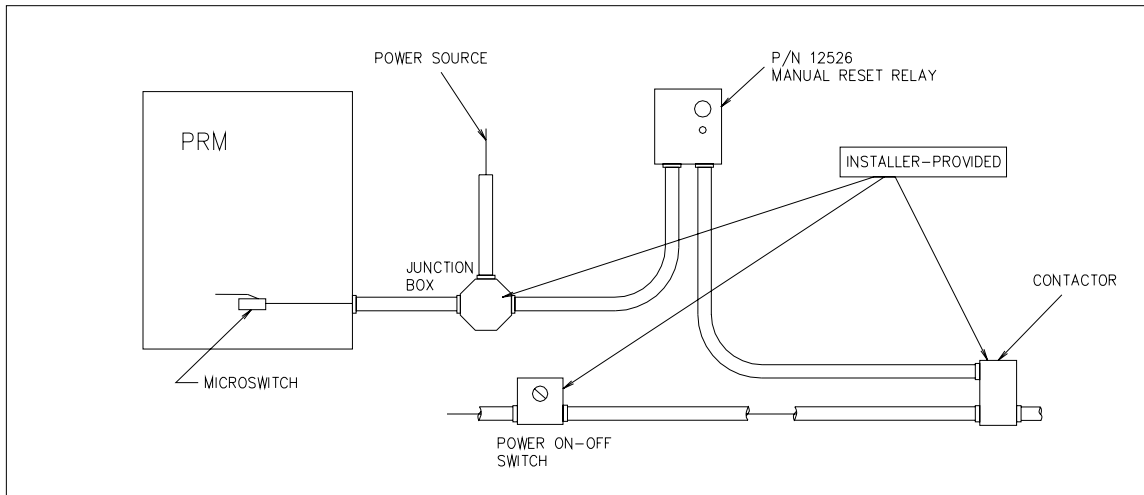

BASIC WIRING DIAGRAM

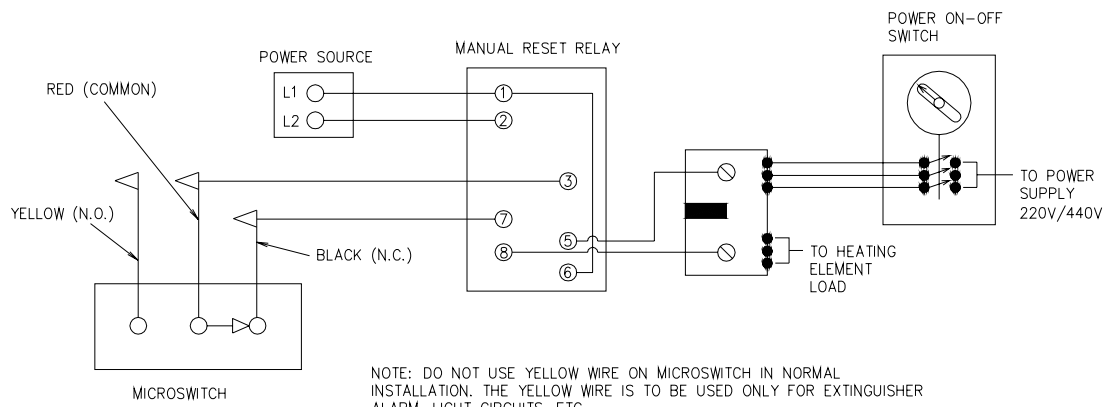

WIRING SCHEMATIC

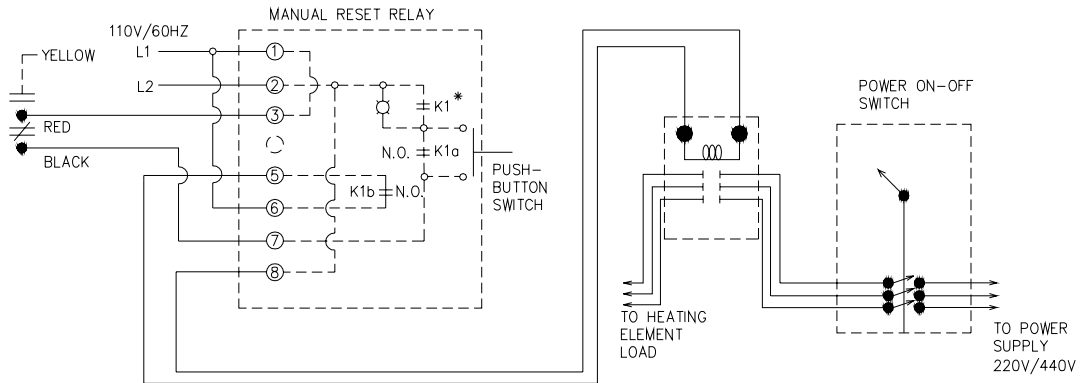

- NOTES:
- 1) ——— DENOTES FIELD INSTALLATION
 - 2) - - - - DENOTES FACTORY INSTALLATION
 - 3) CONTACTOR: UL ENCLOSED INDUSTRIAL CONTROL EQUIPMENT OR MAGNETIC SWITCH HAVING A RATING MATCHING THAT OF THE COOKING EQUIPMENT COIL, 110V / 60 HZ.

Low Pressure Switch (UL file: E225513)

While the pressure gauge of the accumulator cylinder displays the detection system pressure, this gauge may not always be readily visible. The purpose of the low pressure switch is to provide a remote means to alert personnel that the pressure in the pneumatic detection system has dropped to a level approaching system activation (discharge). Any indication of pressure loss in the PRM requires that the system be serviced, without delay, to avoid an unwanted system discharge. Personnel at the installed system location should be trained to recognize the need to contact a trained and certified Amerex distributor in this event.

The PRM is supplied with a SPST pressure switch with contacts that are held open under pressure. The low pressure switch is factory installed and sealed in the top of the 16652 accumulator assembly. The low pressure switch is provided with two wires on each side of the contacts to allow for proper connection to a supervisory circuit on a fire alarm panel. Electrical terminations must be made in UL-listed junction boxes outside the PRM. The switch has gold-plated contacts rated as shown below:

- 50/60 Hz, 36 VDC, 1A
- 120/240 VAC 6.0 FLA, 36 LRA
- 24 VAC 125 VA pilot duty
- 120/240 VAC 375 VA pilot duty

The contacts will close at 50 psig (corresponding to the low side of the “green pie” range on the pressure gauge). **If a noticeable drop in pressure occurs, the pressure switch closing point will allow a short period of time for personnel to act, before the system discharges.** The contacts will re-open at 60 psi, during re-pressurization. When re-pressurizing the PRM, ensure that the contacts re-open, and that any connected device is returned to normal.

LOW PRESSURE SWITCH WIRING SCHEMATIC:

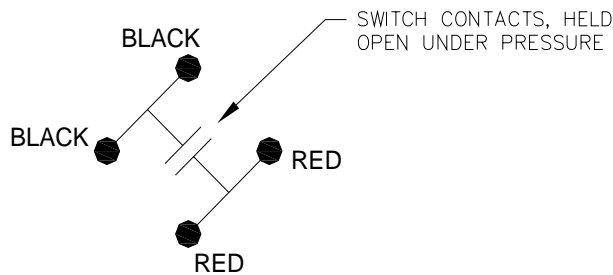

Fire Suppression – Agent Release

Upon either a manual or automatic response to a fire, an internal Nitrogen Cylinder (either the 10 in³ p/n 12856, or the 15 in³ p/n 09956) will expel dry nitrogen, which is pressurized to 1,800 psig (12,411 kPa) at 70°F (21°C). The nitrogen gas is used to open the Agent Cylinder Valves, which in turn, releases the agent. For Actuation Network limitations, see the following:

Type of System	Nitrogen Cylinder Selected	Actuation Network Limitations to Follow
Industrial System (IS)	10 in ³ 15 in ³	p/n 15040 IS Installation Manual – MRM Limitations p/n 15040 IS Installation Manual – ERM Limitations
Restaurant System (KP and ZD)	10 in ³ 15 in ³	p/n 12385 KP or 16640 ZD Installation Manual – MRM Limitations p/n 12385 KP or 16640 ZD Installation Manual – MRM Limitations

Mechanical and Electrical Gas Valve

The PRM is capable of closing up to two (2) mechanical gas valves upon system actuation. Electrical gas valves are operated through the use of the microswitches. Refer to the appropriate Amerex KP, ZD, or IS Installation Manual for design limitations, installation, and servicing instructions of the gas valve(s).

Mechanical Time Delay

If a 10-20 second discharge delay is required (as in the case of Vehicle Paint Spray Booths, for example), the p/n 15765 Mechanical Time Delay is installed at the actuation pressure outlet of the PRM. Refer to the Amerex IS Installation Manual (p/n 15040) for design limitations, installation, and servicing instructions of the Mechanical Time Delay.

PRM Mounting Instructions (Must be Surface-Mounted, Only)

Instructions for mounting (see figure on following page). All installation wiring shall adhere to NFPA 70 (NEC) and all State and Local codes. Terminations of the Microswitches are to be made outside the PRM Enclosure in an appropriate electrical junction box.

Warning: Do not handle the PRM by the red accumulator cylinder. Unnecessary stress on the cylinder and its associated fittings can damage the air-tight seals and lead to leakage. Always handle the unit by the enclosure.

- 1) Remove necessary knockouts on metal enclosure.
- 2) Insert mounting hardware (not provided) into wall, spaced to match keyholes on back of box.
- 3) Mount box on to the screws.
- 4) Tighten all screws.

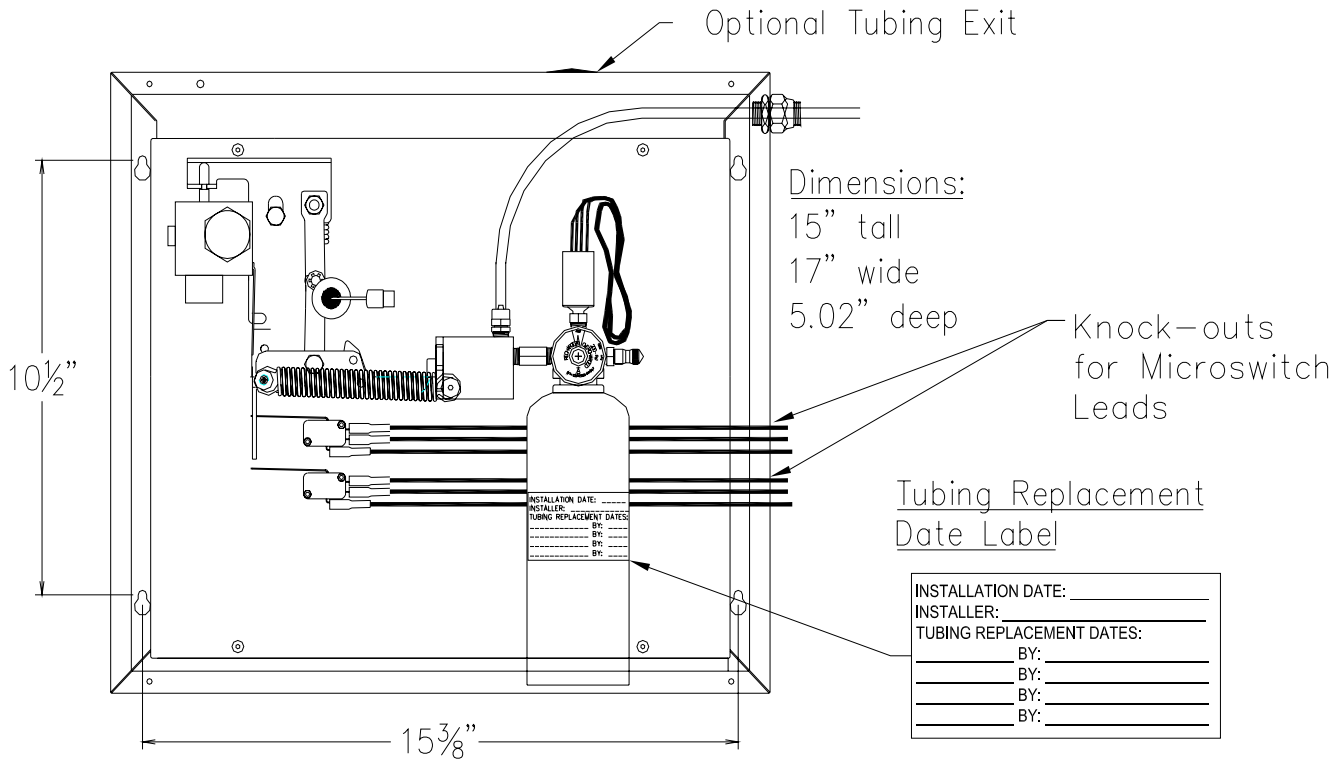

III) Maintenance / Recharge:

Inspection and Servicing the Detection Tubing: The tubing must be replaced at intervals not to exceed three (3) years. Record the installation date and the date of replacement on the tubing replacement label on the Detection Accumulator Cylinder (see figure above). The label is shipped in the bag assembly with the Control Panel. The entire length of tubing must be replaced, either at the three year interval or following a fire incident. If grease or coating build-up is excessive, a more frequent replacement interval will be required. At a minimum, excessive build-up is defined as when material completely encircles the tube at **any** point along its length. Cleaning of the tube is acceptable, provided that no abrasives are used, and that the text on the outside of the tubing is still legible when completed. Use only a soft cloth with mild detergents and warm water. **If the tubing appears brittle or charred, REPLACE it. "When In DOUBT, Take It OUT."** **Brittle or charred tubing is evidence of excessive temperatures on the tubing. Corrective action should be taken to re-evaluate the environment where the tubing is installed, or a more frequent tubing inspection and/or replacement interval must be used.** The End of Line Fitting assembly (p/n 16506) must be replaced when the tubing is replaced. Do not attempt to re-use either the Fitting or the Sealing Ball. Thoroughly leak check tubing terminations following re-installation and re-pressurization.

Accumulator Assembly Replacement Interval: The Accumulator Assembly, p/n 16652, must be replaced at a twelve (12) year interval from the date of installation, or more frequently, if damage or corrosion is suspected. This replacement schedule coincides with a typical cylinder hydrotest interval. Use the installation date as noted on the tubing replacement label located on the accumulator cylinder.

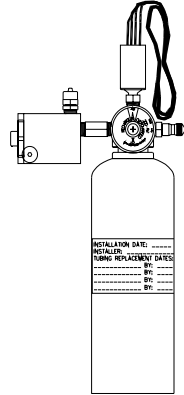

p/n 16652 Accumulator Assembly

Testing the Detection Network: When first placing the system into service, following system actuation, or at the six month servicing interval, the Detection Network shall be tested:

- 1) Remove the Nitrogen Actuation Cylinder.
- 2) Slowly release the detection pressure until the panel actuates by depressing the Schrader valve core on the Detection Accumulator assembly. Replace Schrader cap following actuation, resetting, and re-pressurization.

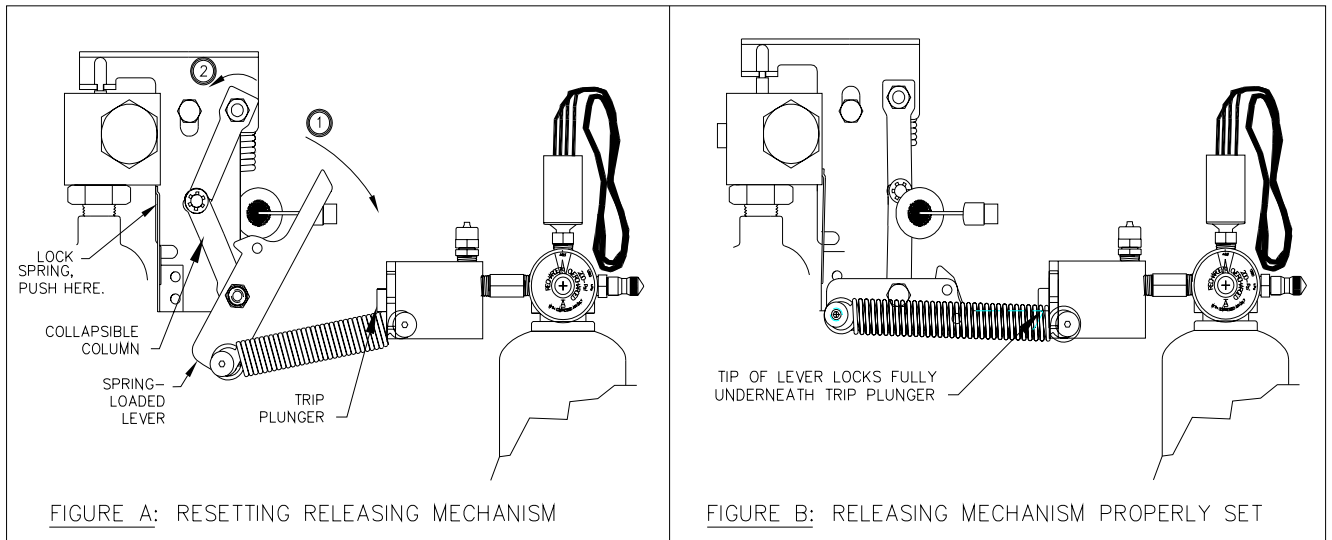

Resetting Steps, Following Panel Activation / System Release: (if a manual actuation has occurred, first reset the Manual Pull Station)

- 1) Pressurize the Accumulator Cylinder to approximately 35 PSI with compressed air through the Schrader Valve. The Trip Plunger should extend.
- 2) Rotate the Spring Loaded Lever clockwise (“1” in Figure A), until its tip is latched under the Trip Plunger. Resume pressurization of the Accumulator Cylinder to 70 PSI at 70°F. Leak check the fittings at both ends of the tubing. Re-make tubing terminations, if necessary.
- 3) Using the Amerex Cocking Tool, p/n 13341 in conjunction with a 3/8” drive socket wrench and extension, re-cock the Collapsible Column (“2” in Figure A). This is accomplished by simultaneously pushing in on the Lock Spring while turning the Cocking Tool counterclockwise. The mechanism should now appear as depicted in Figure B.
- 4) Follow Maintenance and Recharge Instructions in the applicable Amerex Installation, Operation, and Maintenance Manual with regard to the Manual Pull Station(s), Actuation Network, Distribution Piping, and Mechanical and Electrical Gas Valves.
- 5) Replace the Nitrogen Actuation Cylinder (p/n 12856 or 09956).

IV) Replacement Parts:

P/N	Description
12524	Microswitch, for auxiliary field wiring
16501	Tubing Clip (Bag of 25)
16506	End of Line Fitting Assembly (with Sealing Ball)
16557	25' Tubing Roll
16551	50' Tubing Roll
16556	75' Tubing Roll
16552	150' Tubing Roll
16554	300' Tubing Roll
12856	10 in ³ Nitrogen Actuation Cylinder
09956	15 in ³ Nitrogen Actuation Cylinder
16502	Quickseal Compression Fitting, 1/4"
16652	Accumulator Module
16860	Tubing Cutter
17109	Sealing Balls

Warranty Statement:

Amerex warrants its Pneumatic Releasing Module to be free from defects in material and workmanship for a period of three (3) years from the date of purchase. During the warranty period, any defective part will be repaired or replaced (at Amerex option). This warranty is valid only if:

1) each system is installed, serviced, and maintained by an Amerex factory trained Authorized Distributor in strict accordance with this Amerex Manual No. 16546, and the appropriate KP (No. 12385), ZD (No. 16640) and/or IS (No. 15040) Amerex Installation, Operation and Maintenance Manual; 2) customer records verify that the system has been serviced at the required interval(s) in strict accordance with the appropriate aforementioned Manual. All work must be performed using genuine Amerex replacement parts. This Warranty does not cover defects resulting from modification, alteration, misuse, exposure to corrosive conditions or improper installation or improper maintenance. Warranties on component items not manufactured by Amerex are provided by others whose warranty, evaluation, and judgement will be final. **ALL IMPLIED WARRANTIES, INCLUDING, BUT NOT LIMITED TO, WARRANTIES OF FITNESS FOR PURPOSE AND MERCHANTABILITY, ARE LIMITED TO THE TIME PERIOD AS STATED ABOVE. IN NO EVENT SHALL AMEREX CORP. BE LIABLE FOR INCIDENTAL OR CONSEQUENTIAL DAMAGES.** Some states do not allow limitations on how long an implied warranty lasts or the exclusion or limitation of incidental or consequential damages, so that the above limitations or exclusions may not apply to you. Amerex Corp. neither assumes nor authorizes any representative or other person to assume for it any obligation or liability other than as expressly set forth herein. This Warranty gives you specific legal rights, and you may also have other rights which vary from state to state. To obtain performance of the obligation of this Warranty, write to Amerex Corp., P.O. Box 81, Trussville, AL 35173-0081, U.S.A. for instructions.

Six-Month Maintenance Procedure for Pneumatic Release Module ('PRM', - p/n's 16547 / 16795); Amerex Addendum, February, 2008

General:

Due to the variations in installed environments, Amerex is requiring that the following maintenance steps be added to the **six month system maintenance interval**. In summary, this work involves removing and replacing the oring on the brass actuation piston, as well as cleaning and re-lubricating the piston oring and piston bore. Following re-assembly and pressurization, the unit must be leak-checked and fully function-tested as outlined in the current maintenance section by depressurized by depressing the Schrader Valve on the side of the red accumulator cylinder.

Materials Required: 1 1/8" open-end wrench, 5/32" Allen wrench, clean, lint-free shop towels, oring (p/n 17692), Visilox lubricant (available as p/n 06247 in a 5 oz. tube), and this maintenance addendum.

Warning: To prevent unwanted system discharge, **remove the nitrogen actuation cylinder and install its safety cap prior to this service**. Properly place the system back into operation when completed, per the applicable Amerex system manuals (16546-PRM, 12385-KP, 16640-ZD, 15040-IS).

STEP 1: Remove the cover of the PRM. Remove the nitrogen actuation cylinder and install its safety cap. Remove the screw anchoring the spring to the brass block with a 5/32" Allen wrench (see photo, at right). The silver lever should now swing down away from the brass block.

STEP 2: Unscrew the cap off of the Schrader valve and bleed the pressure off of the accumulator cylinder. Confirm that the pressure gauge reads zero.

STEP 3: With the 1 1/8" open-end wrench, loosen and remove the brass hex nut that retains the piston spring and piston inside the brass block. A shop towel may be required to grip the end of the brass piston for extraction from the block. Take care to use only your hands to remove the piston. See image at right.

Very Important: **DO NOT** use pliers or tools to remove the piston from the bore or the oring from the piston groove. Scratches will cause system leaks and unwanted system discharges.



STEP 4: With a clean shop towel, wipe out all the old grease from inside the cylindrical bore at the deepest point inside the brass block. Using the Visiolox V-711 lubricant, **thoroughly and completely** wipe the internal bore in a circular motion with a clean finger. Make sure that you reach all the way to the rear of the bore with the lubricant.

STEP 5: Clean off the old grease from the piston oring. Using a dry shop towel, 'pinch' the oring until it can be slipped over the end of the piston by hand. **DO NOT** use a sharp instrument to remove or cut the old oring off of the piston – scratches on the brass will create a leak point. Clean the groove of the piston prior to installing the new oring. Liberally lubricate the oring on the piston with Visilox before inserting into the brass block, see photo at right.



Very Important:

Lubricate both the o-ring and the internal bore! Use NO TOOLS to remove the old o-ring!

STEP 6: After inserting the new piston all the way into the bore, slide the spring over the end and re-tighten the brass hex retaining nut until resistance is felt. Do not over-tighten, as spring tension will prevent the nut from backing out. See photo at right.



STEP 7: Temporarily pressurize accumulator through the Schrader valve with approximately 40-50 psi. Re-attach the screw which retains the lever spring to the corner of the brass block. Tighten securely. Latch the tip of the actuation lever under the exposed tip of the piston.

STEP 8: Apply the lube totally around the perimeter of the exposed brass piston tip of the trip mechanism. See the photo at right for external lubrication points. Work the piston in and out several times to distribute the lube. Additionally, place some lube on the tip of the spring-loaded lever where it contacts the underside of the piston tip.

Actuation
Lever

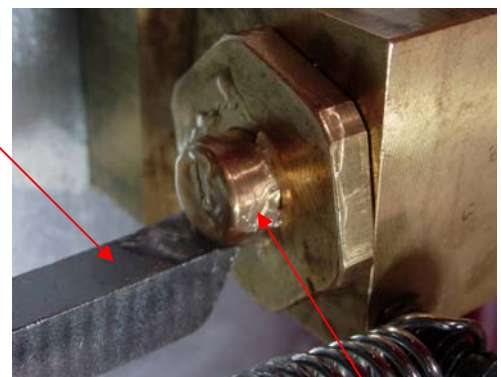

Piston
Tip

Step 9: Repressurize to 70 psi and leak check all fittings. Perform a full function test of the PRM at this time, as well as the remainder of the six month maintenance procedures, per the applicable Amerex system manuals (16546-PRM, 12385-KP, 16640-ZD, 15040-IS).



Please take a moment and leave any written comments or suggestions you may have:

Status (please check one)

- I am new to Amerex Pre-engineered Systems
- I am renewing my existing certificate

Please rate the following items on a scale of 1 to 5.
 1 being lowest or disagree and 5 being highest or strongly agree.

The pace of the training					
1	2	3	4	5	
Layout of the material provided to support the training					
1	2	3	4	5	
Layout of the presentation					
1	2	3	4	5	
Facilitates for the training					
1	2	3	4	5	
The presenter was knowledgeable on the subject matter					
1	2	3	4	5	
This information will be valuable in my job					
1	2	3	4	5	





Pre-Engineered Systems

Training

How to register for the Amerex Certification and Training (ACT) learning site.

For computer access, open your browser and navigate to, <https://amerex-fire.learn.com/>



Please Login	
Username: <input type="text"/>	If you are not yet registered, click here to register now.
Password: <input type="password"/>	
<input type="button" value="Enter"/>	
Forgot password?	

For access with your smart phone or similar device, use the QR code at the bottom of the page.

Once the main page loads, select the “click here to register now” link and you will be redirected to a registration form.

If you are not yet registered,
[click here to register now.](#)

Once your certificate has been verified your access will be granted. **You will not receive a notification when your access is granted.**

Return to the same url, <https://amerex-fire.learn.com/> and enter your username and password. (these are case sensitive so make note of the username and password that you enter on the registration form)

Please Login	
Username: <input type="text"/>	<input type="button" value="Enter"/>
Password: <input type="password"/>	
Forgot password?	

Click the “contact us” link if you have any questions.

